



Model 5900
Snack/candy Vendors

Including New
Real-Time Clock-Calendar
Field Service Manual



5900 Snack / Candy Vendor

Field Service Manual and Parts Catalog

This manual contains procedures for operating and servicing the Rowe 5900 family of Snack / Candy Vendors. The 5900 family includes the 593 (5/10 column), 594 (4/8 column), and the 591 (3/6 column) Snack / Candy Vendors. The 5900 Snack / Candy Vendors are capable of vending a wide variety of products in several different dynamic configurations. The 5900 (model 593) machine can house up to 75 snack delivery motors and will operate in both the United States and international markets. The machine will host a variety of credit acceptance devices including: coin changers, bill validators and debit card readers. The controller possesses many sales features including: a scrolling point of sale message, a WIN-A-SNACK vending mode, multiple purchase discounts, programmable lockout feature, real-time clock/calendar, and complete MIS accountability.

Part Number 900-59303 H
Eighth Edition
First Printing November 1995
Printed in U.S.A.

TABLE OF CONTENTS

SPECIFICATIONS	vi
HOW TO USE THIS MANUAL	vii
COIN MECH USAGE CHART	viii
PRODUCT CLEARANCES	ix
PRODUCT CAPACITIES - 5900C	x
PRODUCT CAPACITIES - 5900S	xi
PRODUCT CAPACITIES - 5900JR	xii
SELECTION IDENTIFICATION	xii, xvi
SECTION 1 - INSTALLATION	
Unpacking	1-1
Set-up Instructions	1-1
Bill Acceptor Switch Settings	1-3
SECTION 2 - DESCRIPTION	
Product Shelves	2-2
Gum and Mint Unit	2-3
Coin Mech	2-4
Selection Identification	2-5
Temperature Control	2-5
Special Vending Modes	2-6
Point of Sale Messages	2-8
MIS	2-9
SECTION 3 - PROGRAM OPERATION	
Diagnostic Mode	3-1
Error Messages	3-1
Service Mode Flow Chart	3-2
Service Mode Operation	3-3
MIS Retrieval	3-7
SECTION 4 - TROUBLESHOOTING	
Table of Contents	4-1

SPECIFICATIONS: 5900S, 5900JR & 5900C SNACK/CANDY VENDORS

GENERAL

	<u>5900S (5 Column)</u>	<u>5900JR (4 Column)</u>	<u>5900C (3 Column)</u>
Depth	35-1/2" (87 cm)	35-1/2" (87 cm)	35-1/2" (87 cm)
Width	39-3/16" (96 cm)	33-13/16" (83 cm)	28-1/2" (70 cm)
Height	72" (176.5 cm)	72" (176.5 cm)	72" (176.5 cm)
Net Weight	Approximately 600 to 750 lbs. (1320 - 1650 kg.)		
Shipping Weight	Depending upon configuration		
Air Cooled Models	Refrigerant - R-12 / Charge - 14 oz.		

ELECTRICAL

Power Requirements		BTU Output	
U.S. Domestic	120 VAC 15A	Without refrigeration	100 BTU/hr
Non-Domestic	220/240 VAC, 50Hz., 12A	With refrigeration	1500 BTU/hr
Power Consumption			
Without refrigeration	.030 kWh (Avg.)		
With refrigeration	.440 kWh (Avg.)		

COIN MECHANISMS

120 V Models - 12 Pin

MARS
COINCO

TRC - 6000, MC 5000
9300L

BILL ACCEPTORS
 ROWE *MAKA *MARS

*NOTE: Contact bill acceptor manufacturer.

24 V Models - 15 Pin only

MARS
COINCO

TRC - 6010 - XV
9302 LF

CARD READERS
 Contact Card Reader manufacturer for machine compatibility.

European Coin Mechs

MARS
ASKOYN
NRI

MS 1600, MS 1900
CASHFLOW
AN - 200
6-26.4400

CAUTION !
 Do not use 24 volt Coin Mech with 12 pin plugs! This will result in permanent damage to the Coin Mech and/or vending machine.

VENDOR CAPACITY - Number of Selections

5900S	5900JR	5900C
5 Shelf 25, 30, 35, 40, 45, or 50 plus Gum and Mint (5 selections)	5 Shelf 20, 24, 28, 32, 36, or 40 plus Gum and Mint (4 selections)	5 Shelf 15, 18, 21, 24, 27, or 30 plus Gum and Mint (3 selections)
6 Shelf 30, 35, 40, 45, 50, 55, or 60 plus Gum and Mint (5 selections)	6 Shelf 24, 28, 32, 36, 40, 44, or 48 plus Gum and Mint (4 selections)	6 Shelf 18, 21, 24, 27, 30, 33 or 36 plus Gum and Mint (3 selections)

HOW TO USE THIS MANUAL

This manual contains six sections. The front section contains a table of contents, tables and charts to aid in the identification of vendor models by number and specifications for each. Described below is a brief outline of the numbered sections and the information discussed there.

SECTION 1 - INSTALLATION - Section 1 contains unpacking, set-up instructions and Bill Acceptor DIP Switch settings. Use this section to install and check out the vendor.

SECTION 2 - DESCRIPTION - Section 2 contains a general introduction to the 5900 Snack / Candy Vendor. This section provides an overview of the machine's major components, as well as explanations of its vending and management features. Before attempting to operate this vendor, read and familiarize yourself with this section and Section 1 - Installation.

SECTION 3 - PROGRAM OPERATION - Section 3 contains step-by-step instructions on how to program all of the machine's features, set prices and access MIS information.

SECTION 4 - TROUBLESHOOTING - Section 4 contains it's own table of contents, troubleshooting procedures, and Error Message & Problem / Solution Troubleshooting Charts. Wiring diagrams and machine schematics are also located in this section. Use this in conjunction with the information in Section 5 - Maintenance, to isolate and repair vendor malfunctions.

SECTION 5 - MAINTENANCE - Section 5 contains instruction for cleaning the snack vendor. It also includes instructions for removing and replacing the shelves, helixes, drive motors, and the Gum and Mint Unit.

SECTION 6 - PARTS CATALOG -Section 6 contains it's own table of contents, a list of optional kits and views of each assembly with the part and section called out. Part numbers under a four digit assembly number are indented to the right if they are shipped as a group when ordering the assembly number. If they are not indented they must be ordered individually.

COIN MECH CHART

VENDING MACHINE COIN MECH USAGE													
Coin Acceptors	406				425				505	548	550	5900	
	6 PUMP		8 PUMP		W.A.D		W/O/BA	W/BA	W.A.D				
Coinco	W/O/BA	W/BA	W/O/BA	W/BA	W.A.D	W/O/BA	W/BA	W.A.D					
9300S <small>Single Price \$12.75 Max 120 VAC</small>	X		X			X							
9340S <small>Single Price \$12.75 Max 120 VAC</small>	X	X	X	X		X	X						
9360S <small>Single Price \$12.75 Max 120 VAC</small>	X	X	X	X		X	X						
S75-9800B-907 <small>Single Price \$3.15 Max 120 VAC</small>	X		X			X							
S75-9400B-977 <small>Single Price \$1.15 Max 120 VAC</small>	X		X			X							
F300E-9210 <small>Four Price \$3.15 Max 120 VAC</small>	3	3	3	3		X	X						
F300-9400 <small>Four Price \$3.15 Max 120 VAC</small>	X		X			X							
S300-9410 <small>Single Price \$3.15 Max 120 VAC</small>	X	X	X	X		X	X						
9300L <small>Micromech 110 VPDC</small>					X			X	X	X	X	X	X
9302LF <small>Micromech 24 VPDC 15 Pin Con.</small>										X	X	X	X
9300L+ <small>Micromech 24 VPDC 16 Pin Con.</small>										X			X
MARS													
Cashflow										X	X	X	X
TRC6010XV <small>Micromech 24 VPDC 15 Pin Con.</small>										X	X	X	X
MC5000 <small>Micromech 117 VPDC \$12.75 Max</small>					X			X	X	X	X	X	X
TRC6000 <small>Micromech 117 VPDC \$12.75 Max</small>					X			X	X	X	X	X	X
TRC6200 <small>120V Single Price \$6.35 Max</small>	X	X	X	X		X	X						
TRC6200H <small>120V Single Price \$6.35 Max</small>	1	4		4			4						
TRC6800 <small>120V Single Price \$10.00 Max</small>	X	X	X	X		X	X						
TRC6800H <small>120V Single Price \$10.00 Max</small>		4		4			4						
MC5802 <small>Single Price 115 VAC</small>	X	X	X	X		X	X						
MC5807 <small>Single Price 115 VAC</small>	X	X	X	X		X	X						
MC5920 <small>Four Price 115 VAC \$6.35 Max</small>	X	2	X	2		X	2						
MC5920H <small>Four Price 115 VAC \$6.35 Max</small>													
MS1600 <small>European 24 VAC 50 Hz</small>									X	X	X	X	X
MS1700 <small>European Tropicalized 24 VAC 50 Hz</small>									X	X	X	X	X
MS1900 <small>European 24 VAC 50 Hz</small>									X	X	X	X	X
NRI <small>National Rejectors Inc.</small>													
G-26.4400 <small>European 24 VAC 50 Hz</small>									X	X	X	X	X
Askoyn													
AN-200									X				X

Product Clearances

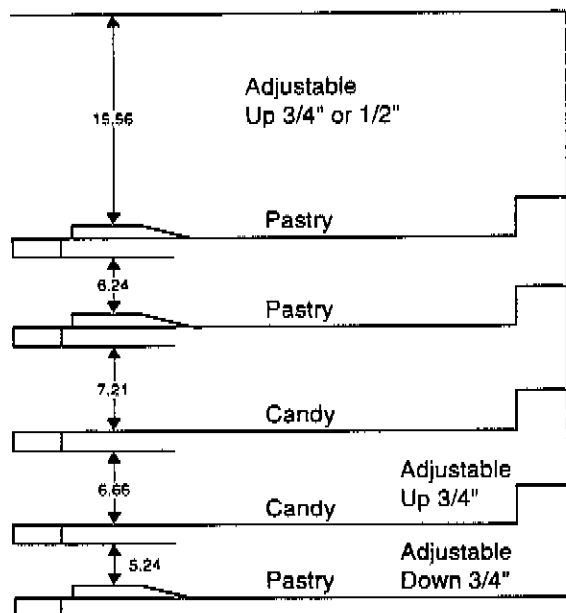

5 SHELF

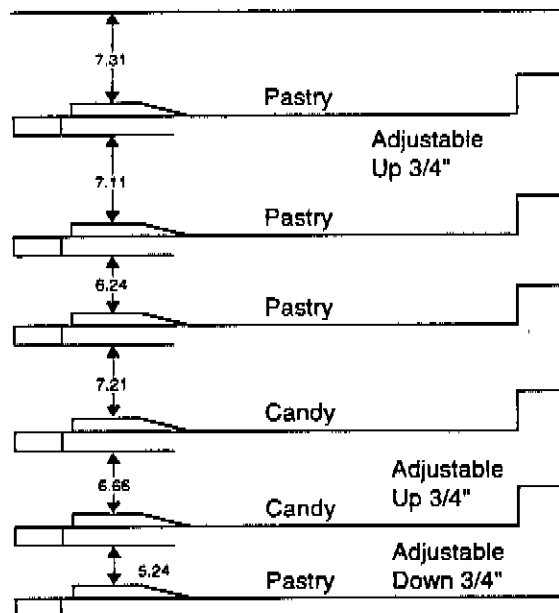

6 SHELF

On both 5 shelf and 6 shelf models the second shelf from the bottom can be adjusted 3/4" higher or lower. There are three sets of rail mounting holes. On 5 shelf models the top shelf can be adjusted up 3/4" or 1-1/2". On 6 shelf models the fifth shelf from the bottom is adjustable up 3/4".

NOTE: Product used must not exceed 7" in height.

Product Widths

5900C - 3 Selection Shelves 5900JR - 4 Selection Shelves 5900S - 5 Selection Shelves				5900C - 6 Selection Shelves 5900JR - 8 Selection Shelves 5900S - 10 Selection Shelves			
Items per Compartment	Helix Part Number	Max. Product Thickness	Product Width	Items per Compartment	Helix Part Number	Max. Product Thickness	Product Width
6	593-14	3-5/16"	2-1/2" / 5-1/4"	10	493-16	2"	1" / 2-1/4"
7	490-4013	2-13/16"	2-1/2" / 5-1/4"	12	493-15	1-5/8"	1" / 2-1/4"
10	490-34	2-1/16"	2-1/2" / 5-1/4"	15	490-31	1-5/16"	1" / 2-1/4"
12	490-33	1-11/16"	2-1/2" / 5-1/4"	18	490-30	1-1/16"	1" / 2-1/4"
15	490-32	1-5/16"	2-1/2" / 5-1/4"	24	490-29	3/4"	1" / 2-1/4"

NOTE:

- 5900S** - The partition in selection 4 can be moved to any of 4 locations, altering the width of selections 4 and 5. The maximum width of selection 4 is 6-3/4". The minimum width for selection 5 is 3-3/4".
- 5900JR** - The partition in selection 3 can be moved to any of 4 locations, altering the width of selections 3 and 4. The maximum width of selection 3 is 6-3/4". The minimum width for selection 4 is 3-3/4".
- 5900C** - The partition in selection 2 can be moved to any of 4 locations, altering the width of selections 2 and 3. The maximum width of selection 2 is 6-3/4". The minimum width for selection 3 is 3-3/4".

5900C COMPACT VENDOR PRODUCT CAPACITIES 6 SHELF MODELS

Model 591-18-6
Capacity 218 Items*

10	10	10
10	10	12
12	12	12
12	12	12
12	12	15
15	15	15

Model 591-21-6
Capacity 290 Items*

10	10	10
10	10	12
12	12	12
12	12	15
15	15	18
18	18	24
15	15	15

Model 591-24-6
Capacity 363 Items*

10	10	10
12	12	12
15	15	15
18	18	18
18	18	18
15	15	15
15	15	24
12	12	12

Model 591-24-6
Capacity 363 Items*

10	10	10
12	15	15
18	18	18
18	18	18
18	18	18
15	15	15
15	15	24
12	12	12

Model 591-30-6
Capacity 497 Items*

10	10	15
12	12	12
18	18	18
18	18	18
18	18	18
18	18	18
18	18	15
15	15	15
15	15	24
15	15	24

Model 591-33-6
Capacity 571 Items*

10	10	15
18	18	18
18	18	18
18	18	18
18	18	18
18	18	18
18	18	15
15	15	15
15	15	24
15	15	24

Model 591-36-6
Capacity 630 Items*

15	15	15
18	18	18
18	18	18
18	18	18
18	18	18
18	18	18
18	18	15
15	15	15
15	15	24
15	15	24

* Each machine includes a 3-selection gum & mint unit with a 135 product capacity. The gum and mint capacity is in addition to the indicated capacities.

5 SHELF MODELS

Model 591-15-5
Capacity 182 Items*

10	10	10
10	10	12
12	12	12
12	12	12
15	15	15

Model 591-18-5
Capacity 254 Items*

10	10	10
10	10	12
12	12	12
12	12	12
12	12	12
15	15	15

Model 591-21-5
Capacity 321 Items*

10	10	10
12	12	15
18	18	18
18	18	18
15	15	15
15	15	24
12	12	12

Model 591-24-5
Capacity 395 Items*

10	10	15
18	18	18
18	18	18
18	18	18
15	15	15
15	15	24
12	12	12

Model 591-27-5
Capacity 495 Items*

18	18	18
18	18	18
18	18	18
18	18	18
15	15	15
15	15	24
12	12	12

Model 591-30-5
Capacity 540 Items*

18	18	18
18	18	18
18	18	18
18	18	18
18	18	18
15	15	15
15	15	24
12	12	12

* Each machine includes a 3-selection gum & mint unit with a 135 product capacity. The gum and mint capacity is in addition to the indicated capacities.

Three and six selection shelves fit in any position, see chart above. Helix coils can be freely interchanged with other helix coils of different capacities, provided they are the same diameter.

5900S PRODUCT CAPACITIES 6 SHELF MODELS

Model 5930S
Capacity 370 Items*

10	10	10	10	10
10	10	12	12	12
12	12	12	12	12
12	12	12	12	12
12	12	15	15	15
15	15	15	15	15

Model 5935S
Capacity 502 Items*

10	10	10	10	10			
10	10	12	12	12			
12	12	12	12	12			
12	12	15	15	15			
15	15	18	18	24	24	24	18
15	15	15	15	15			

Model 5940S
Capacity 617 Items*

10	10	10	10	10				
12	12	12	12	12				
15	15	15	15	15				
18	18	18	18	18	18	18	18	18
15	15	15	15	24	24	24	18	18
15	15	15	15	15				

Model 5945S
Capacity 734 Items*

10	10	10	10	10				
12	15	15	15	15				
18	18	18	18	18	18	18	18	18
18	18	18	18	18	18	18	18	18
15	15	15	15	24	24	24	18	18
15	15	15	15	15				

Model 5950S
Capacity 839 Items*

10	10	15	15	15				
12	12	12	12	12				
18	18	18	18	18	18	18	18	18
18	18	18	18	18	18	18	18	18
18	18	18	18	15	15	15	15	15
15	15	15	15	24	24	24	15	15

Model 5955S
Capacity 955 Items*

10	12	12	12	15				
18	18	18	18	18	18	18	18	
18	18	18	18	18	18	18	18	
18	18	18	18	18	18	18	18	
18	18	18	18	15	15	15	15	
15	15	15	15	24	24	24	15	15

Model 5960S
Capacity 1062 Items*

15	15	15	15	15	15	15	15	15
18	18	18	18	18	18	18	18	18
18	18	18	18	18	18	18	18	18
18	18	18	18	18	18	18	18	18
18	18	18	18	15	15	15	15	15
15	15	15	15	24	24	24	18	18

Model 5970 (7 Shelf)
Capacity 1050 Items*

15	15	15	15	15	15	15	15	15
15	15	15	15	15	15	15	15	15
15	15	15	15	15	15	15	15	15
15	15	15	15	15	15	15	15	15
15	15	15	15	15	15	15	15	15
15	15	15	15	15	15	15	15	15

6 SHELF MODELS

Model 5925S
Capacity 310 Items*

10	10	10	10	10
10	10	12	12	12
12	12	12	12	12
12	12	15	15	15
15	15	15	15	15

Model 5930S
Capacity 437 Items*

10	10	10	10	10			
15	15	12	12	12			
15	15	15	15	15			
15	15	18	18	24	24	24	18
12	12	12	12	12			

Model 5935S
Capacity 551 Items*

10	10	10	10	10				
15	15	15	15	15				
18	18	18	18	18	18	18	18	
15	15	15	15	24	24	24	18	18
15	15	15	15	15				

* Each machine includes a 5-selection gum & mint unit with a 225 product capacity. The gum and mint capacity is in addition to the indicated capacities.

Model 5940S
Capacity 677 Items*

10	10	15	15	15				
12	12	12	12	12				
18	18	18	18	18	18	18	18	
18	18	18	18	18	18	18	18	
15	15	15	15	24	24	24	18	18

Model 5945S
Capacity 793 Items*

10	12	12	12	15				
18	18	18	18	18	18	18	18	
18	18	18	18	18	18	18	18	
18	18	18	18	18	18	18	18	
15	15	15	15	24	24	24	18	18

Model 5950S
Capacity 894 Items*

18	18	18	18	18	18	18	18	
18	18	18	18	18	18	18	18	
18	18	18	18	18	18	18	18	
18	18	18	18	15	15	15	15	
15	15	15	15	24	24	24	18	18

5900C Selection Identification

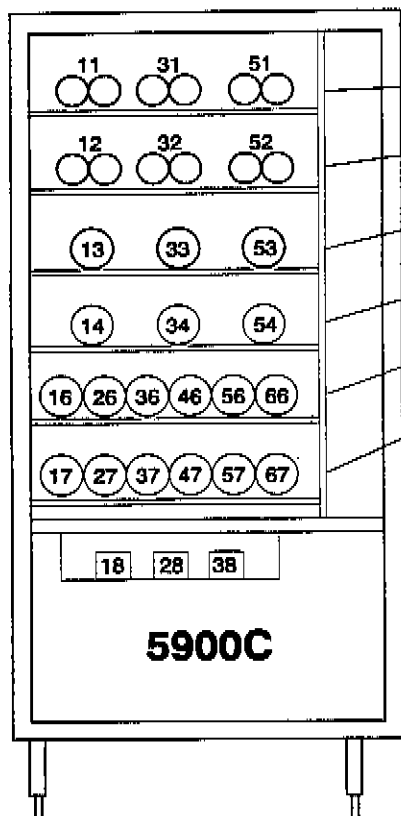

Selection Identification Label Assortment P/N 593-1908

01	11	21	31	41	51	61
02	12	22	32	42	52	62
03	13	23	33	43	53	63
04	14	24	34	44	54	64
06	16	26	36	46	56	66
07	17	27	37	47	57	67
	18	28	38			

Affix labels on shelves, left to right, as shown.

On a Universal Shelf configured as a 3 column shelf use the numbers circled above.

On a Universal Shelf configured as a 6 column shelf start with the SECOND number and proceed left to right. DO NOT use 01, 02, etc., on 3 Column vendor.

The top shelf is always identified with the lowest number series, i.e., 01 or 11.

Start with #18 on the Gum and Mint Unit.

* If vendor is a seven shelf model the Gum and Mint selections will be: 19 - 29 - 39.

5900JR Selection Identification

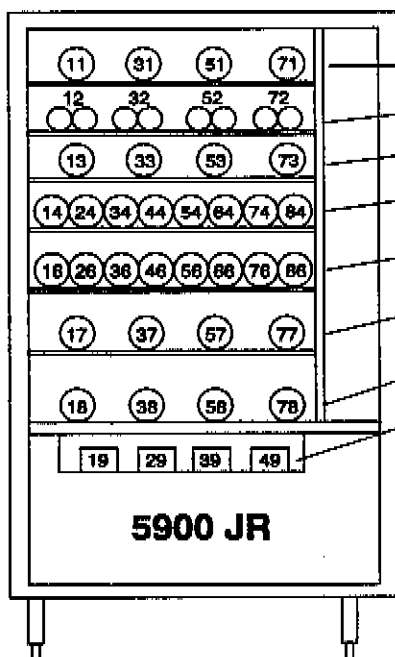

Selection Identification Label Assortment P/N 593-1908

01	11	21	31	41	51	61	71	81
02	12	22	32	42	52	62	72	82
03	13	23	33	43	53	63	73	83
04	14	24	34	44	54	64	74	84
06	16	26	36	46	56	66	76	86
07	17	27	37	47	57	67	77	87
08	18	28	38	48	58	68	78	88
	19	29	39	49				

Affix labels on shelves, left to right, as shown.

On a Universal Shelf configured as a 4 column shelf use the numbers circled above.

On a Universal Shelf configured as an 8 column shelf start with the SECOND number and proceed left to right. DO NOT use 01, 02, etc., on 5900 JR.

Always start with #19 on the Gum and Mint Unit.

* If vendor is a six shelf model the Gum and Mint selections will be: 18 - 28 - 38 - 48 - 58

5900S Selection Identification

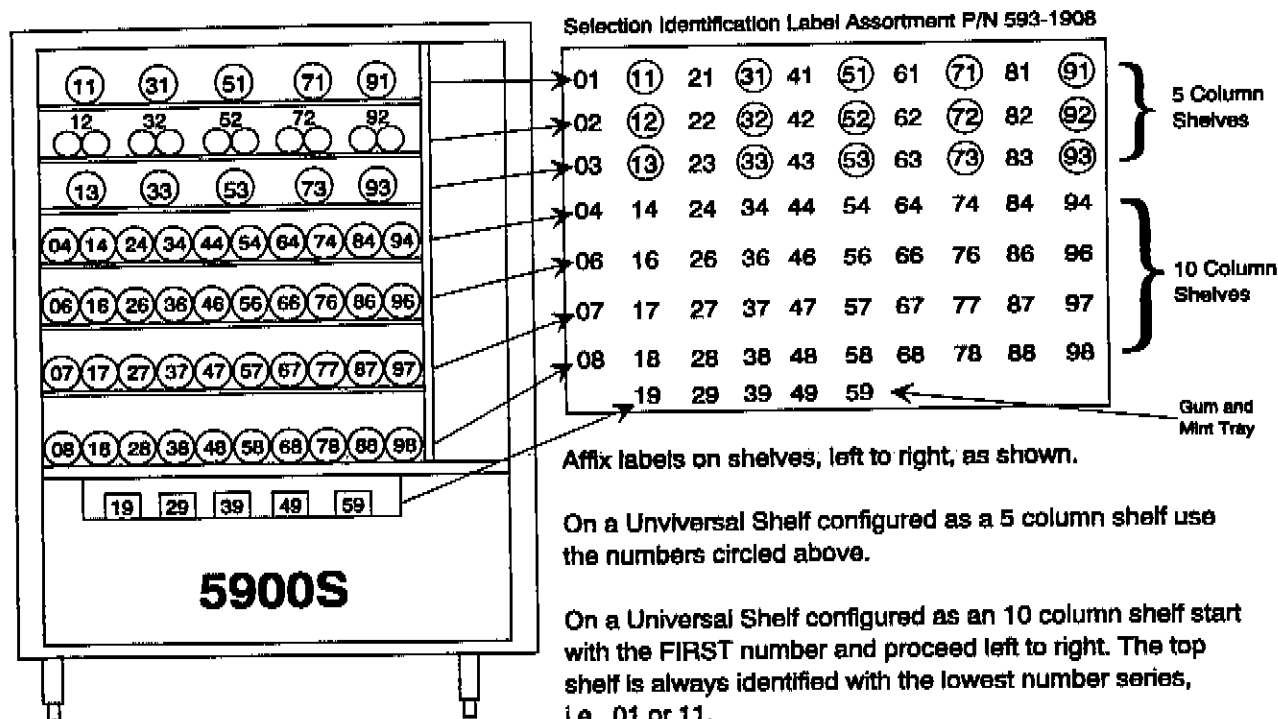

SECTION 1

INSTALLATION

This section contains instructions for unpacking, moving and installing the 5900 vendor on location. Installation is quick and easy when done in the proper sequence.

UNPACKING

The Snack Vendor is shipped in one carton with all major assemblies in place, ready for installation. Inspect the exterior and interior of the cabinet for evidence of damage. In case of damage, please notify the delivering carrier at once to examine the vendor regardless of the external condition of the carton. Under U.S. regulations, damage claims must be collected by the consignee. Do not return shipping-damaged merchandise until after your claim has been established. Once your claim is established, damaged merchandise may then be returned to your Rowe Distributor for repair. The invoice for repair charges may then be collected from the carrier. Do not destroy packing material or boxes until the carrier's agent has examined them.

SET-UP INSTRUCTIONS

Preliminary (Primary Delivery)

If it is necessary to move the vendor through a narrow doorway, proceed as follows. The power cord anchoring plate can be dismantled from the rear wall, allowing the power cord and plug to be pushed into the cabinet. Be certain to remount the anchoring plate to prevent damage to the power cord. If more clearance is required it will be necessary to pivot the door hinges.

1. Open the main door.
2. Remove the door stop rod.

3. Disconnect the door harness at the plug, located below the delivery box on the hinge side.
4. Disconnect the bill acceptor harness at the power box on the cabinet floor (if so equipped).
5. Open the main door far enough to expose the three counter sunk screws in the top hinge. Block the door to support its weight.

CAUTION !

The door is heavy. Take appropriate precautions before proceeding.

6. Remove the two 1/2" hex head bolts from the cabinet side of the top hinge plate.
7. Remove the three counter sunk screws and nuts from the top hinge plate on the door.

NOTE:

Take care not to lose the bearing washer on the bottom hinge pin in next step.

8. Rotate the upper hinge assembly away from the door frame and lift the door straight "up" off the lower hinge point.
9. If additional clearance is required, the lower hinge can be pivoted by removing the FRONT 1/2" hex head bolt and loosening the rear bolt one turn. The security shield mounted on the left front edge of the cabinet is also removable if required.

CAUTION !

The Main switch must be OFF when changing, connecting or disconnecting any electrical components.

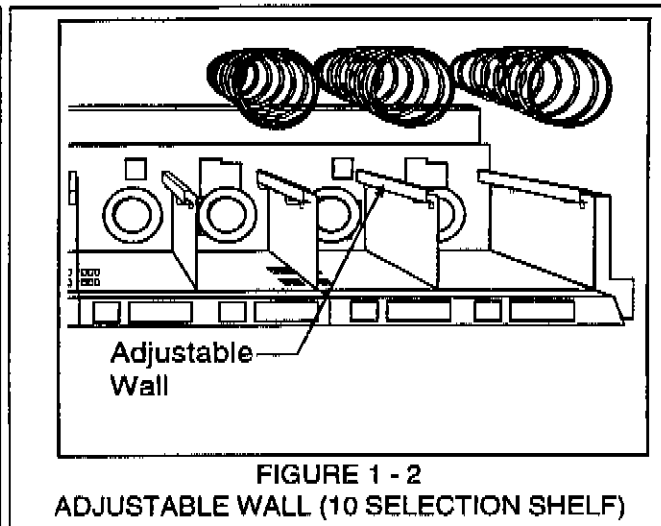
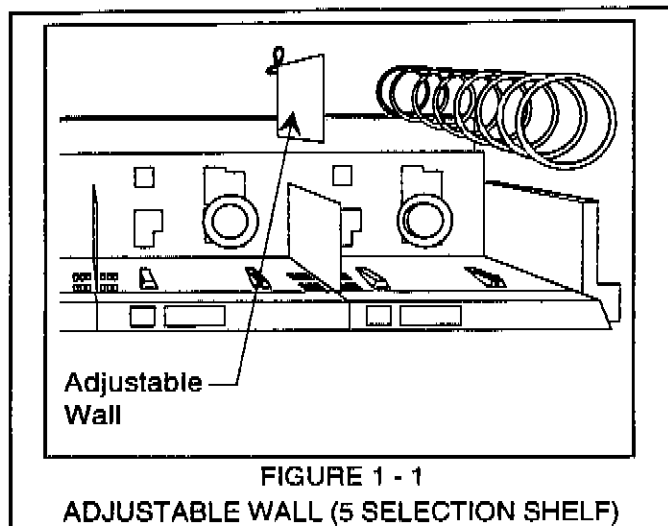

10. After passing through the confined area, reassemble the door to the cabinet, being certain to secure all of the parts and harnesses removed in the preceding steps.

Initial Set-up Procedure

Set up the vendor as follows:

1. Open the main door all the way.
2. Set the main switch to OFF.
3. Level the cabinet front to rear and side to side. All four cabinet legs are adjustable.
4. Ensure that the fluorescent lamp is secure in its socket and that all electrical plugs are firmly seated in their sockets.
5. Plug the line cord into an appropriate receptacle. Ensure good ground.
6. Install a recommended coin mech, if applicable. See Specification sheet on page vi.
 - a) Check coin chute alignment.
 - b) Check return lever operation.
 - c) Adjust if necessary.
7. Set the main switch to ON.
8. Set pricing. (See Program Operation, Section 3.)
9. Pull the top product shelf out and lower it to the loading position. Load product in accordance with the specifications listed at the beginning of this manual.
10. Three (591), four (594) and five (593) selection shelves feature an adjustable wall to the left of the far right spiral. The wall can be installed in any one of the four positions in the bottom of the tray. After adjusting the wall for the
 11. desired width, check to be certain that the product moves freely when the selection on each side of the adjustable wall is vended (See Figure 1-1 and Page 6-22). Additional tray walls are shipped with each machine and can be installed in the pastry tray slots to accommodate the narrower items. On 6, 8 or 10 selection trays, the adjustable wall swings out from the right side of the shelf wall (See Figure 1-2).
 12. Install product pushers where required. The plastic product pushers are snapped onto the helix in the desired position to assure product delivery (See Page 2-2, Figure 2-1).
 13. Place selection identification labels on selections according to pages xiii & xiv.
 14. Place price labels on selections.
 15. Gum and Mint Assembly: Unclip price cover bezel and install selection number and price label.
 16. Gum and Mint Assembly: Reinstall the price cover bezel by snapping it into place.
 17. Gum and Mint Assembly: Load the horizontal Gum and Mint Unit by grasping the pair of handles located on the front of the machine and pulling forward. Slide the cover to the rear of machine.
 18. Gum and Mint Assembly: After sliding the cover forward, push the Gum and Mint Unit back into position.
 19. Gum and Mint Assembly: Adjust the clear flippers to avoid double vends.
 20. Deposit coins and test vend each selection. Check coin return operation.

UBA Bill Acceptor Switch Settings

All of the DIP switch settings located on the Rowe UBA assembly circuit board must be set to the OFF position, except switch #2, which must be set to the ON position.

BILL ACCEPTOR DIP SWITCH SETTINGS

ROWE	UBA	# 2 ON
MAKA	NBE-20	#1 ON
MARS	VFM-3*	#1, #8 & #7 ON
MARS	VFM**	#2, #6 & #7 ON

* MARS VFM-3 Version 1-3
 ** MARS VFM Version 4-5

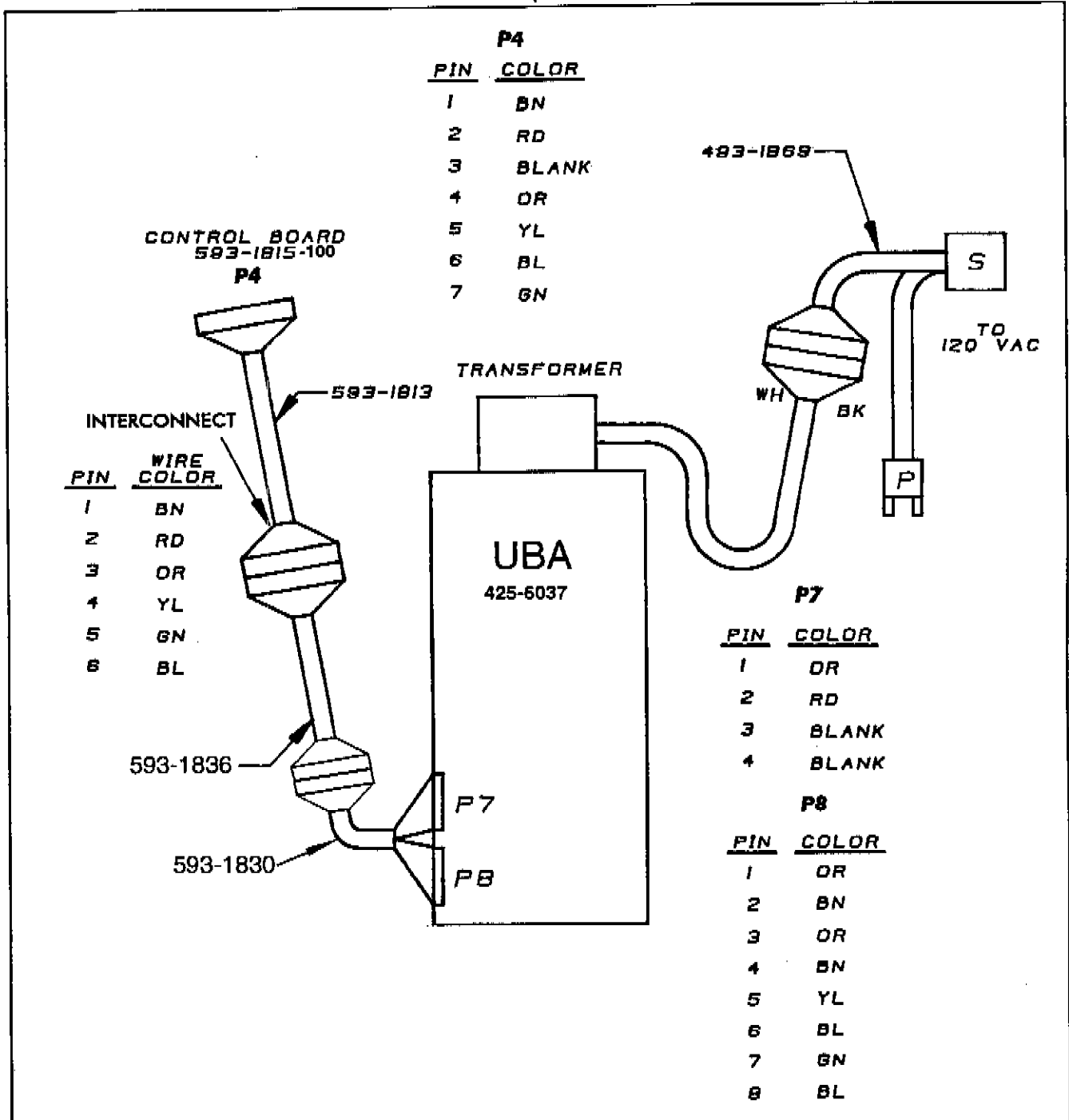

FIGURE 1 - 3 593/594/591 UBA WIRING DIAGRAM

SECTION 2

DESCRIPTION

INTRODUCTION

The Rowe 5900 family of Snack/Candy Vendors includes the large capacity 5900S, the medium capacity 5900JR and the 5900C Compact Vendor. All 5900 models vend a wide variety of products from a combination of dual, pastry and candy helixes. Helixes are available in several capacities and are interchangeable between all three models. Each helix is operated by its own motor for trouble-free long life. State of the art electronics provide quick and easy programming, and detailed Management Information System (MIS) data.

During a purchase, merchandise is moved from the display shelf by a rotating helix coil and dispensed into a delivery compartment easily accessible to the customer. A time tested delivery door is easy for the customer to open, but remains theft-proof.

Units with Dual-Helix Shelves will ensure a positive product flow and frontal alignment of larger products. Universal shelves allow the combination of single and Dual-Helix delivery on any shelf creating many snack combinations.

Machine product capacity depends on the size and variety of helix coils used. Coils are removed and replaced without tools, merely by lifting out the existing helix and dropping the replacement straight in.

Product thickness varies considerably. Choose a helix that is appropriate for the product being vended (Refer to page 2-2). Ensure that product fits loosely within the helix coil. Do not place product into a helix that is too small; damage to the product and the vendor may result. Because some bagged snacks swell in size over their normal shelf life,

some trial selection is necessary. The product thickness range specified in this publication for each helix coil is an approximate measurement and will vary according to factors such as how much a product settles, product type, swelling and weight. Standard shelf capacities for each model are shown on pages x-xii.

The slide-out Horizontal Gum and Mint Unit is mounted on its own shelf. Releasing the latch handles on the front of the unit allows it to be pulled forward for easy loading and servicing. Column widths can be easily adjusted by using the product adjustment guides. Double vending is avoided by sliding the product flipper to the proper location and tightening the knob.

A two note Rowe Universal Bill Acceptor (accepts \$1.00 and \$5.00 bills) is available as an option. The acceptor has single bill escrow. Combination purchases using a bill and coins are possible and change for the purchase is dispensed from the coin mech.

The addition of the optional refrigeration unit extends the sales period of temperature sensitive products. Because the cabinet temperature is maintained between 50° F and 70° F, discoloration and melting of chocolate candies and sugar covered pastries is prevented.

The 5900 controller allows the operator to access special vending functions and management information. Detailed Management Information System (MIS) data is accumulated by the controller and can be printed on an optional printer or displayed, line by line, on the message center.

Product Shelves

Universal Shelves

All of the shelves in the 5900 Snack /Candy Vendor are universal shelves. This means that all shelves use a universal power connection bracket, which allows them to be placed at any position within the machine. A universal shelf can be modified to support any combination of candy, pastry and dual helixes. Modifying shelves requires removing or adding motors and helixes.

Shelf Configurations

Shelves are available in three standard configurations: candy, pastry and dual helix. These shelves can be installed at any position within the machine and can be freely interchanged with any other shelf. Helixes can be interchanged to accommodate different product widths. Refer to page ix for helix capacity and part numbers.

Candy Shelf

A candy shelf has one helix for each possible motor position (593 - 10 Selections, 594 - 8 Selections, 591 - 6 Selections). A candy shelf should be used to vend products up to 2-1/4 inches wide and 2 inches thick.

Pastry Shelf

A pastry shelf has one helix for each pair of motor positions (593 - 5 Selections, 594 - 4 Selections, 591 - 3 Selections). A pastry shelf should be used to vend products that are 2-1/2" to 5-1/4" wide and 1-5/16" to 2-1/16" thick.

Dual Helix

Dual helix shelves have two helixes working in conjunction with each other at each pair of motor positions (593 - 5 Selections, 594 - 4 Selections, 591 - 3 Selections). A dual helix selection is driven by a single motor which turns a gear and sprocket arrange-

ment, rotating the helixes in opposite directions. A dual helix shelf is used to vend products that are 2-1/2" to 5-1/4" wide and 1-5/16" to 2-1/16" thick.

Adjustable Shelf Wall

The 5900 Snack/Candy Vendor uses adjustable shelf walls to accommodate varying product widths.

Dual helix and pastry shelves (3, 4 or 5 selection) have an adjustable shelf wall located between the last two selections on the right side of the shelf. The divider can be removed and placed in one of the four slots in the bottom of the tray. Additional dividers are shipped with each machine.

On candy shelves (6, 8 or 10 selections) the adjustable wall swings out from the right side of the shelf wall.

Loading a Shelf

1. Pull the shelf forward to the loading position.
2. Place product between the helix coils. Start from the front and work toward the rear.
3. Adjust the shelf walls to fit the product. Ensure that product moves freely.

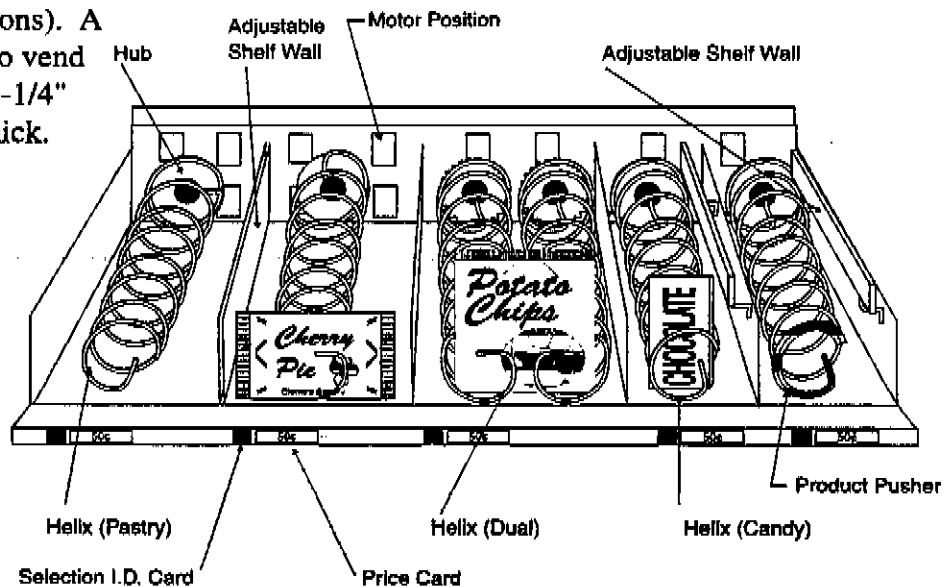

Horizontal Gum and Mint Unit

The 5900 Snack/Candy Vendor uses a horizontal gum and mint unit located on its own shelf. The unit slides out of the vendor for easy loading and servicing.

Operation

Product is vended from the gum and mint unit by a motor and product ejector system. During a vend, the motor turns and raises the product ejector. The ejector pushes the product up and over the front of the gum and mint unit. The flipper ensures that only one product is released during each vend. The flippers can be adjusted forward or back to coordinate with the product size. Adjustable product guides can be installed to accommodate narrow product.

Loading the Gum & Mint Unit

To load the Gum and Mint Unit:

1. Grasp the latch handles and pull the unit forward until it stops. This is the loading position.
2. Slide the cover to the rear of the unit.
3. Install adjustable product guides, if necessary, to accommodate narrow product.
4. Place product in the appropriate selections.

NOTE:

Do NOT attempt to pull the product pushers forward toward the product. This will damage the constant force springs. When the unit is returned to the vend position, the product pushers will be seated properly against the product.

6. Return the Gum and Mint Unit to the vend position.
7. Test vend each selection. Adjust the flippers to prevent double vending.

Delivery Door Closure Rate

A dashpot (air damping cylinder) controls the rate at which the delivery door closes. The closure rate can be adjusted to accommodate different vendor models and customer preferences. The adjustment screw is located on the top of the mounting box. Turn the screw clockwise to decrease the air flow and slow the closure rate. Turn the screw counterclockwise to make the door close faster.

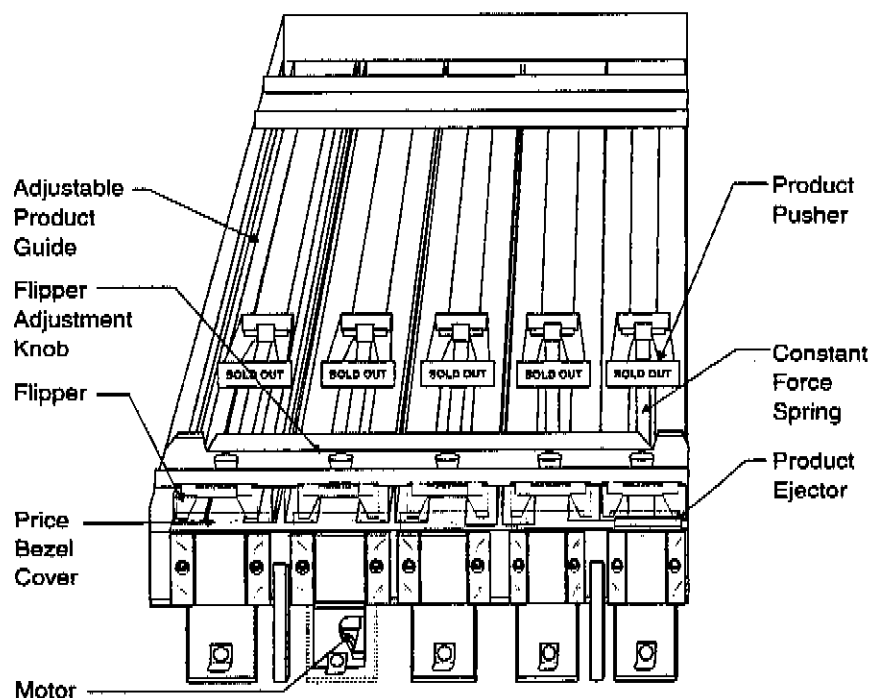

Figure 2-2

Coin Mechanism (Domestic)

A coin mechanism (coin mech) is required to operate this vendor. Refer to page vi or vii for compatible coin mech listings. The coin mech works in conjunction with other credit acceptance devices, such as a bill validator or debit card reader, to accept and dispense coins during a vend. The 5900 controller regulates the number of coins accepted and dispensed through the coin mech.

Installing the coin mech

5900 Snack Vendors are compatible with several different coin mech models. The coin mech should be installed according to the directions provided by the coin mech manufacturer.

Because this vendor can operate several different coin mech models, it is important to ensure that the coin mech installed on your vendor is aligned properly with the coin chute located on the vendor. Also check to ensure that the vendor's coin return lever actuates the coin return lever on the coin mech. Make the adjustments necessary for the coin mech to operate properly.

Coin Mech Loading

There are three methods of loading coins into the coin mech while in the service mode:

1. Coins can be added to the coin mech through the normal coin insert located on the customer display. If coins are loaded in this manner the number of coins is registered by the controller and automatically added to the coin tube total.

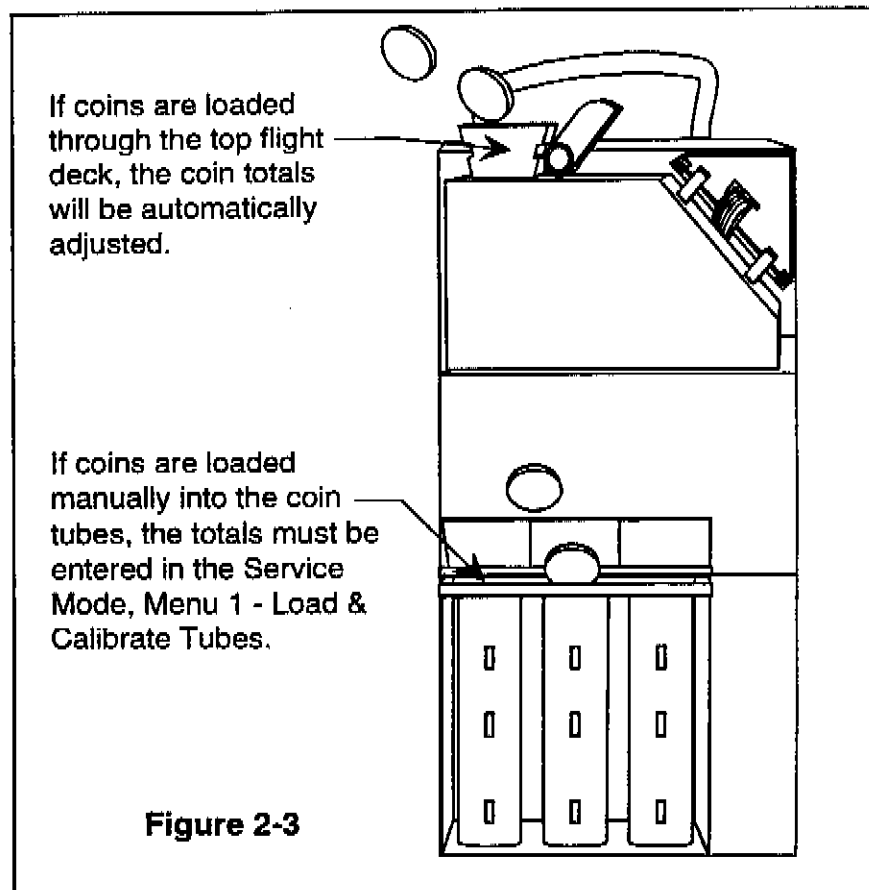

Figure 2-3

2. Coins can be added through the top flight deck located on the top of the coin mech. If coins are loaded through the top flight deck, the number of coins is registered by the controller and automatically added to the coin tube total.
3. Coins can be added through the side of the coin mech, directly into the coin tubes. If coins are added directly to the coin tubes they are not registered by the controller, and the number of coins loaded must be entered using Menu 1 - Load and Calibrate Coin Tubes, in the Service Mode. **It is extremely important to record the correct number of coins when loading coins directly into the coin tubes. Payout and acceptance criteria are based upon the number of coins in the coin mech.**

SELECTION IDENTIFICATION

(See page xiii & xiv)

Selection identification is as follows:

First digit:

The first digit identifies the location of an item on the shelf.

Dual Helix & Pastry Shelves

On all models with a 3, 4, or 5 item shelf, the first item from the left is 1, the second is 3, the third is 5, etc.

Candy Shelves

On a model 591 or 594, 6 or 8 selection shelf, the first item from the left is 1, the second item is 2, the third item is 3, etc. On a model 593, 10 selection shelf, the first item is 0, the second item is 1, the third item is 2, etc.

Second digit:

The second digit identifies the shelf locations. The top shelf is 1, second from top is 2, third from top is 3, fourth from top is 4, fifth from top is 6, sixth from top is 7. Gum and Mint selections are 9 on a 7 shelf configuration and 8 on a 6 shelf configuration. In the case of a five shelf machine the top shelf is designated as #2.

Examples:

Six Shelf Machine

Top Shelf - 5 Selection					Fourth Shelf - 5 Selection									
11	31	51	71	91	14	34	54	74	94					
Second Shelf - 5 Selection					Fifth Shelf - 10 Selection									
12	32	52	72	92	04	16	28	38	48	53	65	76	86	96
Third Shelf - 10 Selection					Sixth Shelf - 5 Selection									
03	13	23	33	43	53	63	73	83	93	17	37	57	77	97

Making a Selection

To make a selection, deposit the proper amount of money. The display shows the amount of credit entered. The price is displayed beneath each item. Press the two digits corresponding to the selection number shown beneath the product.

The purpose of the <Reset> button is to erase the first number if it is entered incorrectly. This can also be accomplished by pushing the coin return.

Selection Buttons

There are 10 selection buttons numbered from 1 to 0. There is also a <Reset> button. These buttons are used by the patron to make a purchase from the vendor. They are also used by service personnel to access the service mode and program all of the machine's operating and management features. Refer to Section 3 for detailed programming instructions for the vendor using the service mode.

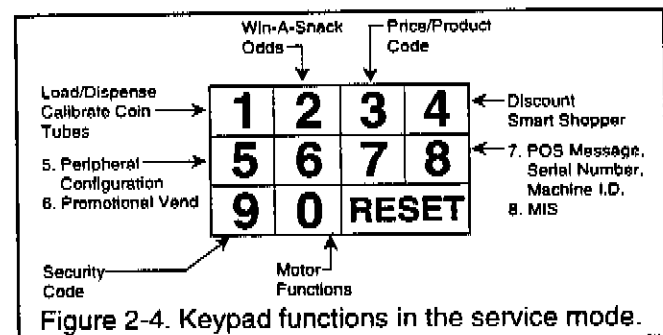

Temperature Control (Optional)

The temperature control knob is mounted to the refrigeration unit, near its AC power input socket, beside the transformer box assembly.

To maintain an even temperature distribution the evaporator blower runs continuously, even if the control is set to off. Turn the temperature control knob slowly clockwise from the off position until the condenser fan and compressor start. Let the system run for twenty (20) minutes before checking the cabinet temperature. If a lower temperature is desired turn the control knob clockwise to the next higher number. Allow the system to run twenty (20) minutes before taking another reading.

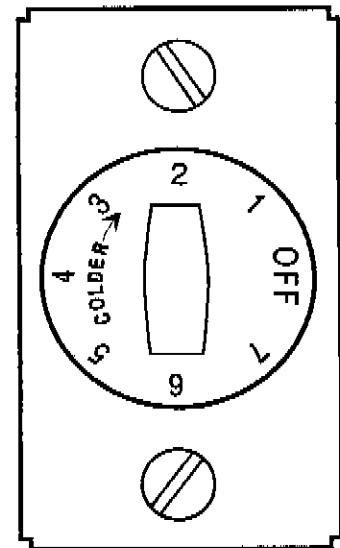

Special Vending Modes

The 5900 incorporates many special vending features. These features are enabled and disabled using the DIP switches located on the 5900 Controller. The DIP switch settings and their associated features are listed below. When the DIP switch is ON, the associated feature is enabled. Setting the DIP switch OFF will disable the feature.

Changing the language setting applies only to the message prompts displayed to the customer (see the list on page 2-8). The text in the service menu as well as error messages will remain in English.

DIP SWITCH SETTINGS

POSITION	ASSIGNMENT
1	Language
2	Language
3	Force Vend
4	Promotional Vend
5	Multivend
6	Win-A-Snack

TABLE FOR LANGUAGE SETTING

POSITION 1	POSITION 2	LANGUAGE
ON	ON	Spanish
ON	OFF	French
OFF	ON	German
OFF	OFF	English

Force Vend

This feature is intended to force credit accrued from a bill validator or coin mech to be used to purchase an item. Escrow attempts of the bills held in the bill validator or coins deposited in the coin mech will not be allowed if this feature is active. This credit will not be returned if a vend is unsuccessful or an invalid selection is made. Change will be made.

Promotional Vend

This feature is intended to free vend a second item when an item is purchased for the programmed price. Five pairs of items may be programmed. See page 3-6 for programming instruction.

Multivend

This feature is intended to increase sales and make multiple purchases more convenient for a customer. After a first selection is made, the "SELECT OTHER ITEM" message will be displayed. The remaining credit will be shown on the display and another selection may be made. If more money is inserted, the credit will remain indefinitely, until a vend is made or the coin return is depressed. If there is no machine activity following the first vend, the remaining credit will automatically be returned after 10 seconds.

Win-A-Snack

This feature is intended to free vend a product on a random basis with a prescribed occurrence level being programmed by the service person. When a Win-A-Snack win occurs, the selected item will be vended and the entire credit will be returned. Range of odds: 1:50 to 1:500 in steps of 50.

Smart Shopper

The smart shopper feature allows the customer to purchase two items of the same selection, and receive the second at a discounted price.

When a discount is programmed, this feature is always enabled. If the discount amount is set to zero or greater than the maximum price this feature will have no effect. All items in the machine will be discounted the same amount as programmed. See page 3-4 for programming instructions.

To operate this feature, the <RESET> button must be pressed twice before a selection is made. The smart shopper mode will remain active for 60 seconds after the reset button is pressed or until a selection is made. A double vend will be conducted on the chosen selection and change will be returned, with the discounted amount being calculated into the second vend's price.

Remote No Sale

When the Remote No Sale Switch is ON, sales on row 4 will be disabled. The "SELECT OTHER ITEM" message will be displayed if a row 4 selection is attempted. This feature may be used to prevent sales of items during particular times (manual setting).

Feature Prioritization

Win-A-Snack and Promotional Vend
Multivend
Smart Shopper Mode
Force Vend

Explanation of Prioritization

Assume the following machine configuration:

Win-A-Snack - ON
Promotional Vend - ON
Force Vend - ON
Smart Shopper Mode - ON

Consider the instance of a Win-A-Snack winner after the <RESET> button has been pressed twice. If a purchased side of a promotional pair is selected and sufficient credit was already inserted from a bill validator, the first item will be vended, then the free item will be vended and the entire amount of deposited money returned. In essence the Force Vend and Smart Shopper features have been overruled by the Win-A-Snack feature but the Promotional Vend was performed in conjunction with a Win-A-Snack winner.

Automatic Lockout

The Automatic Lockout feature is implemented by setting one or more time periods, or events, in which the machine is to be disabled. During a

lockout period, the display will scroll the message "MACHINE DISABLED UNTIL XXXX," where "XXXX" is the time the machine will return to service. There are 10 programmable events available. An event may be programmed to occur on a particular day, every work day (Monday through Friday), or every day of the week. When programming Automatic Lockout events, make sure events do not overlap and OFF times are always later than ON times.

COIN PAYOUT BUTTONS

Four momentary push button switches are located on the control board for dispensing coins. The following coins may be dispensed: nickel, dime, quarter, and dollar (for changers with dollar coin payout). These buttons will only be enabled during a Key <1> Load/Dispense/Calibrate routine in the service mode with a domestic changer connected. The approximate rate of dispense with a button depressed is 2 coins per second. These buttons will be ignored if more than one is pressed.

SERVICE <MODE> BUTTON

The Service <MODE> Button is a momentary push button located on the control board and is used to enter and exit the service mode.

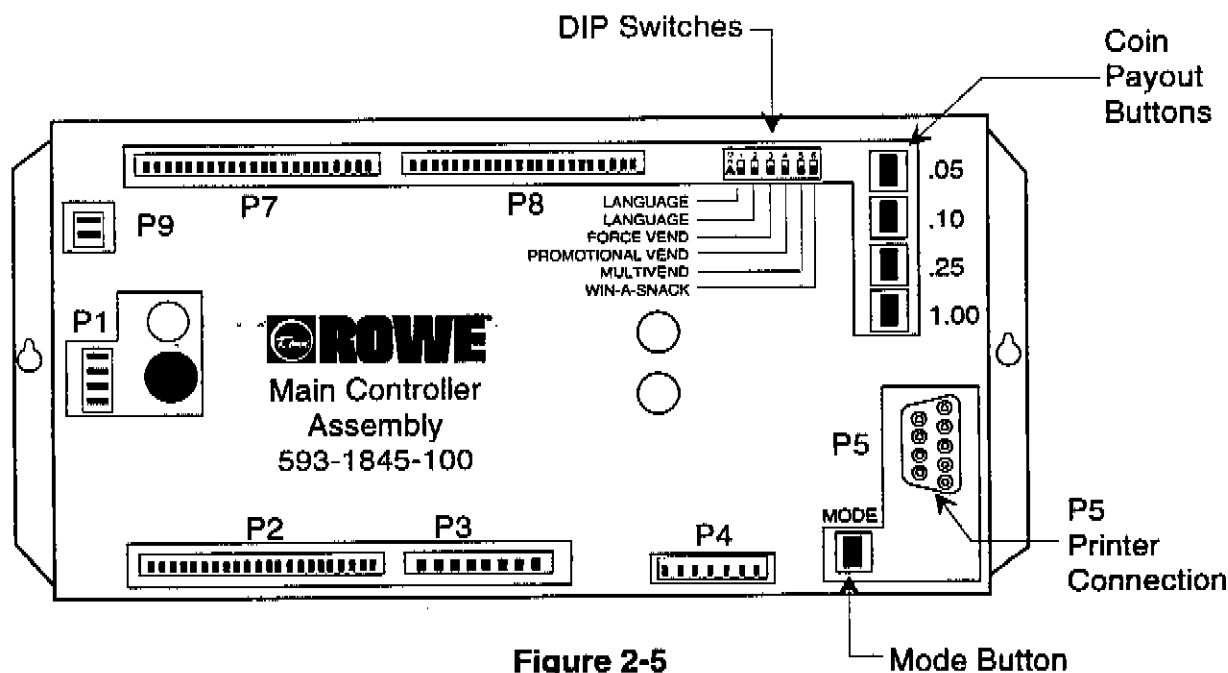

Figure 2-5

DISPLAY MESSAGE PROMPTS

“EXACT COINS ONLY”

This message is scrolled when the changer reports that the nickel tube does not contain any coins above the low level sensor. With an MS 1900 Coin Mech, the controller will scroll this message when the changer is signaling an exact change only status (i.e., less than 4 nickels in the coin tubes).

“SELECT OTHER ITEM”

This message is shown on the display when a vend is attempted on row 4 with the unit programmed for Remote No Sale, following an unsuccessful vend, following an invalid selection number and during a Multivend operation.

“PRICE”

This message is shown for 600 milliseconds after a valid keypad selection has been made. The selection's price will immediately follow the selection on the display.

“THANKS”

This message is shown for 600 milliseconds following a successful vend and dispensing of change.

“CHANGE”

This message is shown only when using a domestic Coin Mech. It will be shown for 600 milliseconds immediately following a successful vend.

“COINS ONLY”

This message is scrolled when the dime and quarter tubes are empty but the nickel tube has coins.

“MACHINE OUT OF ORDER”

This message is scrolled when a particular peripheral is selected and a valid start-up message is not received. The bill validator will not disable the machine since no start-up message is available. If no peripherals are selected, the machine will display the Point of Sales message.

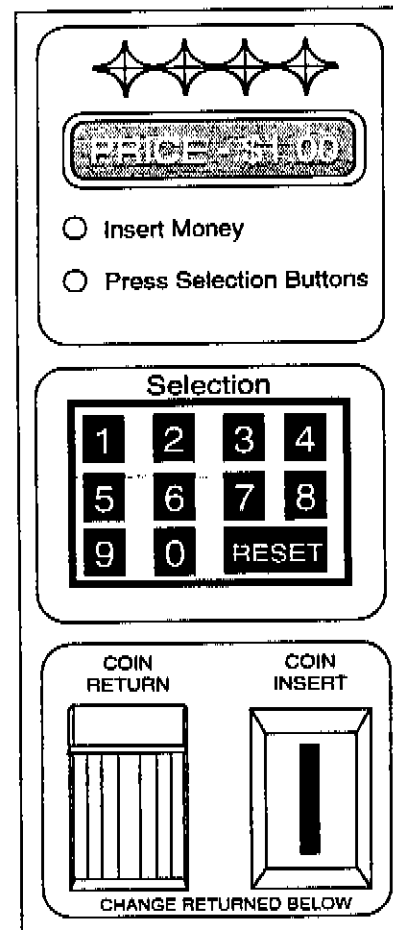

AUDIO FEEDBACK

A piezo-type chime mounted on the display board is sounded for the following events:

- Insufficient credit condition after a selection was made (3 - 300 millisecond beeps)
- Unsuccessful vend (3 - 300 millisecond beeps)
- Between Multivend selections
- Successfully decoded keypad entries
- Opening of the door
- Pressing of the service mode button
- Exit from service mode

The Point of Sale Message

This message is scrolled during periods of no activity when the changer is not exhibiting a low coin tube status. The message will be a maximum of 250 characters in length and will be programmable in the service mode. This message will not be effected by the position of the Language DIP switch. See page 3-8 for instructions on programming this message.

Management Information System (MIS) Data

The 5900 controller stores sales and credit information useful in tracking the vendor's performance. MIS information can be displayed on the customer display or printed with an optional printer. For instructions on accessing MIS information refer to page 3-9.

The following information is collected and stored by the 5900 controller:

MACHINE SERIAL NUMBER:

Range: (Blank) to 9999999999

MACHINE IDENTIFICATION NUMBER

Range: (Blank) to 9999999999

AUDIT NUMBER: (Non-resettable)

Equals the number of times the retrieval of MIS Information has been performed (Mode Key - <7>)

Range: 1 - 99999

SALES (Resettable)

Range: 0 - \$999,999.95

SALES (Non-Resettable)

Range: 0 - \$999,999.95

BAG TOTAL

Equals total accumulation of Cash Box plus Bill total amounts.

Range: 0 - \$999,999.95

CASH BOX

Equals total amount in Cash Box

Range: 0 - \$999,999.95

CARD SALES

Equals total amount in credit sales vended

Range: 0 - \$999,999.95

BILLS IN STACKER: (Where applicable)

BILL TOTAL - Equals all bill denominations in Bill Acceptor Stacker

Range: 0 - \$999,999.00

Ones 0 - \$65,535.00

Twos 0 - \$131,070.00

Fives 0 - \$327,675.00

Tens 0 - \$655,350.00

Twenties 0 - \$999,980.00

COINS IN TUBES:

TUBE TOTAL - Equals all coin denominations in Coin Mech Tubes

Range: 0 - \$357.00

\$1 Coin 0 - \$255.00

Quarters 0 - \$63.75

Dimes 0 - \$25.50

Nickels 0 - \$12.75

WIN SNACK VENDS: Equals the total win counts and cash amount given away.

Range: 0 - \$999,999.95

SHOPPER VENDS: Equals the number of vends and cash amount of discounted product dispensed.

Range: 0 - \$999,999.95

PROMO VENDS: Equals the number of vends and cash amount of free selection vended when making a certain paid selection.

Range: 0 - \$999,999.95

VEND PER PRODUCT CODE: Equals the number of times an assigned product code selection had been vended.

MIS PRINTER SETUP

Previous versions of 5900 software required the printer to be configured with 2400 baud, even parity, 8 data bits, and 1 stop bit. Version 6.0 and later changes this configuration to a selectable baud rate, no parity, 8 data bits, and 1 stop bit. This setup allows the 5900 Snack/Candy Vendor to be configured the same as the Rowe 548 Showcase Merchandiser, the 550 Showcase Merchandiser, and the Rowe CD Jukebox. The same printer may now be used to retrieve data from all these machines without changing the printer setup. Printer wiring has also been simplified. Only three wires are required. Below is the schematic of a generic printer harness. Check the owner's manual for the printer you are using to verify proper connections at the printer end.

5900 Control Board	25 Pin RS232 Printer Plug
(Tx) P5-3-----	Pin 2 or 3 (Rx)
(GND) P5-5-----	Pin 7 (GND)
(CTS) P5-8-----	Pin 5 or 20 (BUSY)

Sample MIS Report

ROWE INTERNATIONAL			

5900 SOFTWARE V 6.0			
ACCOUNT RECORD			
11:22 11-13-95			

SERIAL #	-	0000000000	
MACHINE ID	-	0000000000	
AUDIT NUMBER		23	
SALES (R)	- \$	1.00	
SALES (N)	- \$	26.50	
BAG TOTAL	- \$	6.00	
CASH BOX	- \$.00	
CARD SALES	- \$.00	
BILLS IN STACKER			
BILL TOTAL	-	\$ 6.00	
ONES	-	1 \$ 1.00	
TWOS	-	0 \$.00	
FIVES	-	1 \$ 5.00	
TENS	-	0 \$.00	
TWENTIES	-	0 \$.00	
COINS IN TUBES			
TUBE TOTAL	-	\$ 8.00	
\$1 COIN	-	0 \$.00	
QUARTERS	-	20 \$ 5.00	
DIMES	-	20 \$ 2.00	
NICKELS	-	20 \$ 1.00	
WIN-SNK VENDS	-	0 \$.00	
SHOPPER VENDS	-	0 \$.00	
PROMO VENDS	-	0 \$.00	
FREE VENDS	-	0 \$.00	
VENDS PER PRODUCT CODE			
CODE 01 VENDS	-	2	

Figure 2-6

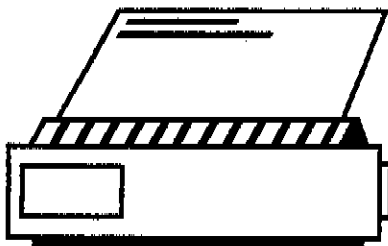

Rowe recommends the Seiko DPU-411-21BU Serial printer for retrieving MIS data. A printer harness, Rowe P/N 593-1800, is required to connect the printer to the controller.

Section 3

Program Operation

Introduction

This section contains detailed instructions on how to program all of the machine's features, retrieve MIS information, set prices, and load and calibrate the coin tubes.

There are two operation modes that the operator can access. The first mode is the Diagnostic Mode, which is activated when the door is opened. The Diagnostic Mode will list recorded machine errors and allow the operator to clear them from the system. The second mode is the Service Mode, through which the operator can program the various machine functions and retrieve MIS information.

In this manual, messages that appear on the display will be shown in upper case letters enclosed by quotation marks. The keys on the selection panel used to program the machine are enclosed in < > marks.

Diagnostic Mode

The following error messages will be displayed during the Diagnostic Mode. They will be displayed repetitively in the following order until cleared or until the Service Mode is entered. To clear an error, press the <RESET> Key. "NO ERRORS" followed by "SYSTEM OK" will be displayed when the last error is cleared.

Error Messages

"OVER CRNT= XX" - This message indicates motors that have been short circuited or jammed.

"HOME FAIL XX" - This message lists motors that have not returned to the home position or that have failed to move from the home position.

"CHK PRICE XX" - This message indicates selections with corrupted or invalid prices.

"LINK PWRUP" - This message appears when a master type peripheral (executive coin mech) is configured and communication is not established.

"CHGR PWRUP" - This message appears when a logic type coin changer is configured and communication is not established.

"CARD PWRUP" - This message appears when a debit card reader is configured and communication is not established.

"BILL ERROR" - This message appears when a bill validator is configured and the validator's diagnostic line has been active.

"COIN JAM" or "BAD SENSOR" - This message appears when a logic coin changer signals either a coin jam or a bad sensor.

"TUBE ERROR" - This message appears when a logic type coin changer is configured and a transaction has been detected on the lower level tube sensors.

To correct any of the errors listed above, refer to Section 4 - Troubleshooting.

Service Mode Flow Chart

Fig 3-1

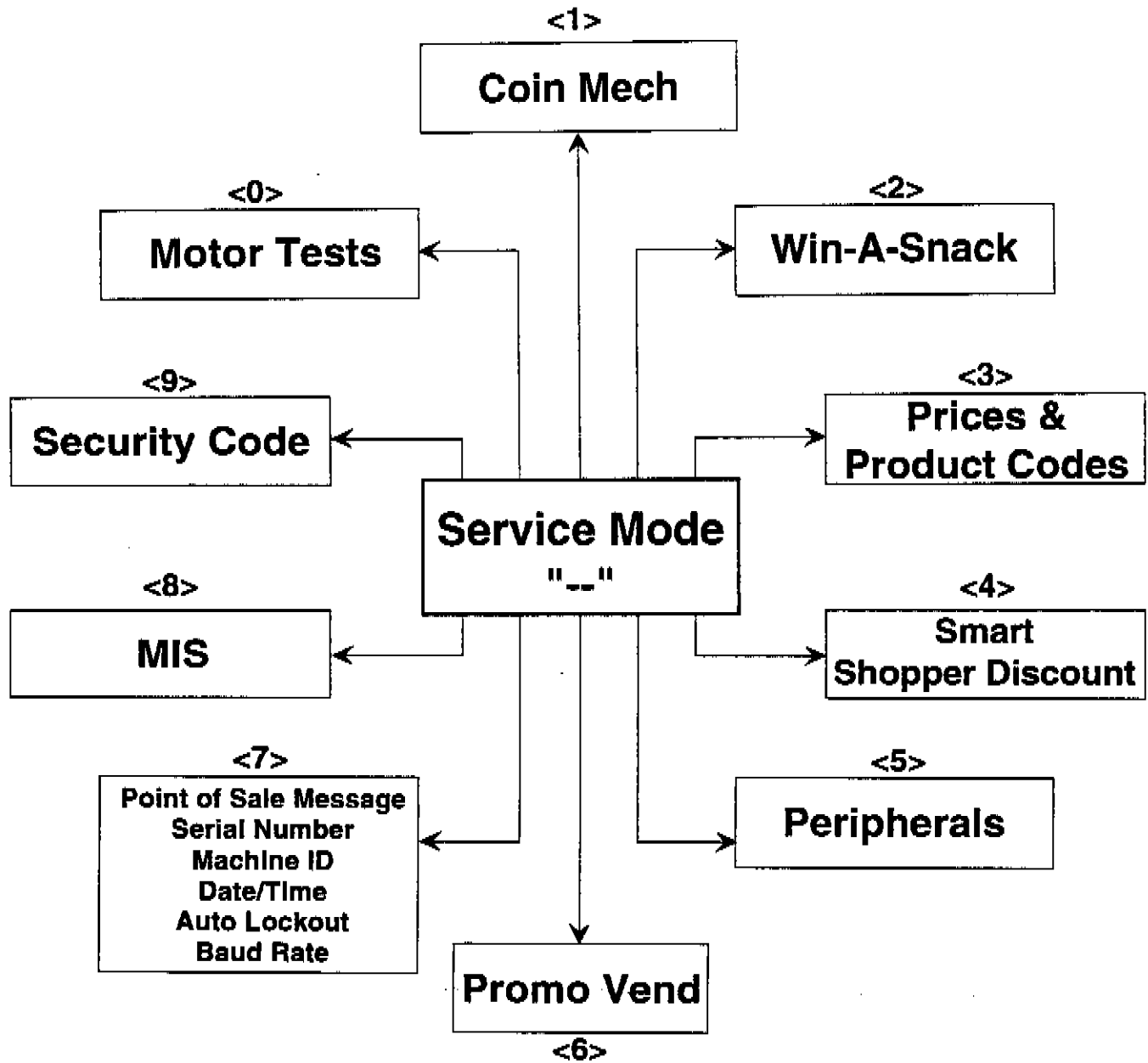

SERVICE MODE OPERATION

The Service Mode is accessed by either pressing the <MODE> button on the control board while the main door is open, or by entering the security code on the keypad. If the security feature is enabled, the service mode must be entered by entering the security code on the keypad, in order to have access to secured menus. Once in the Service Mode, the operator will be able to access all of the 5900's operating and management options. The different options in the Service Mode are located in ten menus. The menus are accessed through the number keys on the keypad. Follow the instructions in this section to program the 5900 Snack/Candy Vendor. Refer to the flow chart on page 3-2.

I. Access the Service Mode

1. Press the <MODE> button on the control board. A dash "-" will appear in the far left display digit indicating that the root service menu has been accessed. If the security feature is enabled, enter the security code using the keypad to gain access to all menus. If there is no keypad activity for 60 seconds, the controller will return to the Diagnostic Mode.
2. Press one of the following keys to access the menu you wish to program.
 - <1> Load and Calibrate the Change Tubes
 - <2> Win-A-Snack Odds Programming
 - <3> Price, Product Code, and Discount Eligibility
 - <4> Smart Shopper and Discount Amount Programming
 - <5> Manual Peripheral Configuration
 - <6> Promotional Vend Pairing
 - <7> POS Message, Serial and ID Number Programming, Date, Time, and Auto Lockout Setup
 - <8> MIS Display and Printer Communications
 - <9> Programming the Security Code and Security Features
 - <0> Motor Functions
3. Press the <RESET> key to exit the current menu and return to the root menu.

II. KEY 1 - Load/Dispense/Calibrate the Changer Tubes

Purpose:

To allow the operator to inventory and adjust the number of coins in the coin tubes. If coins are

manually added to the tubes, the coin count must be adjusted in this menu. If coins are deposited or paid out while in this mode the display will automatically show the inventory level of the last coin dropped. The coin tubes are listed as "NIKLS", "DIMES", "QUTRS" AND "DOLRS".

NOTE:

When coins are paid out below the tube level sensor, the count is reset to four, and coin tube counts may become corrupted.

Programming Instructions

1. Press <1> on the keypad.
2. Response will be: "NICKELS XXX".
XXX represents the number of nickels in the tubes.
3. Press <0> to move to the next coin tube without changing the coin count in this tube.
4. Press <1> to increment the tube total.
5. Press <2> to decrement the tube total.
6. Press <0> to move to the next tube after inventory changes.
7. Press <RESET> to return to the root menu without saving changes.
8. Repeat steps 1-6 for each of the coin tubes.

NOTE:

Payout and acceptance criteria are based on the values of the coin tube levels.

III. KEY 2 - Win-a-Snack Odds Programming

Purpose:

To program the Win-a-Snack odds. The odds range from 1:50 to 1:500.

Programming Instructions:

1. Press <2> on the keypad.
2. Response will be "ODDS 1/XXX". *XXX represents a number between 50 and 500.*
3. Press <1> to increment the odds at intervals of 50.
4. Press <2> to decrement the odds at intervals of 50.
5. Press <0> to save the change and return to the root menu.
6. Press <RESET> to return to the root menu without saving changes.

NOTE:

Dip switch #6 on the control board must be ON to enable this feature.

IV. KEY 3 - Price, Product Code, and Discount Eligibility Setting

Purpose:

To set prices and product codes and to enable the Smart Shopper discount. The amount of the Smart Shopper discount will be programmed in the next menu. Only selections that have a motor present can be modified in this menu.

NOTE:

Ensure that the shelf to be programmed is in the vend position, with the electrical connector at the rear of the shelf engaged with the electrical connector mounted to the cabinet.

NOTE:

When installing a new control board, all selections must be reprogrammed to avoid setting error messages in the diagnostics. Selections that had prices previously set but whose motors are no longer detected will be flagged as "CHK PRICE" in the diagnostic display.

Programming Instructions:

1. Press <3> on the keypad.
2. Response will be "SET PRICE?".
3. Enter a two digit selection number.
4. Response will be "AA BBBB * CC".
'AA' = Selection number
'BBBB' = Price
'' = Discount eligibility*
'CC' = Product code
5. Press <1> to increment the price.
6. Press <2> to decrement the price.
7. Press <3> to increment the product code.
8. Press <4> to decrement the product code.
9. Press <5> to toggle the discount eligibility option (The asterisk indicates that the option is enabled).
10. Press <9> to save the changes. The information saved will be displayed at the next selection on the shelf. To modify the settings on the rest of the selections, repeat steps 5-9. To keep the settings the same, press <9> again. In this manner prices may be copied from one selection to the next.

V. KEY 4 - Smart Shopper Discount Amount

Purpose:

To set the amount of the Smart Shopper discount. The Smart Shopper discount is only valid on items on which the Smart Shopper option was enabled in Menu 3.

Programming Instructions:

1. Press <4> on the keypad.
2. Response will be "DSCNT XXX".
XXX represents the amount of the discount.
3. Press <1> to increment discount.
4. Press <2> to decrement discount.
5. Press <0> to save the discount amount.

When reviewing the settings in Peripheral Configuration, key <6> may now be used to quickly view one setting after another without having to SAVE each setting.

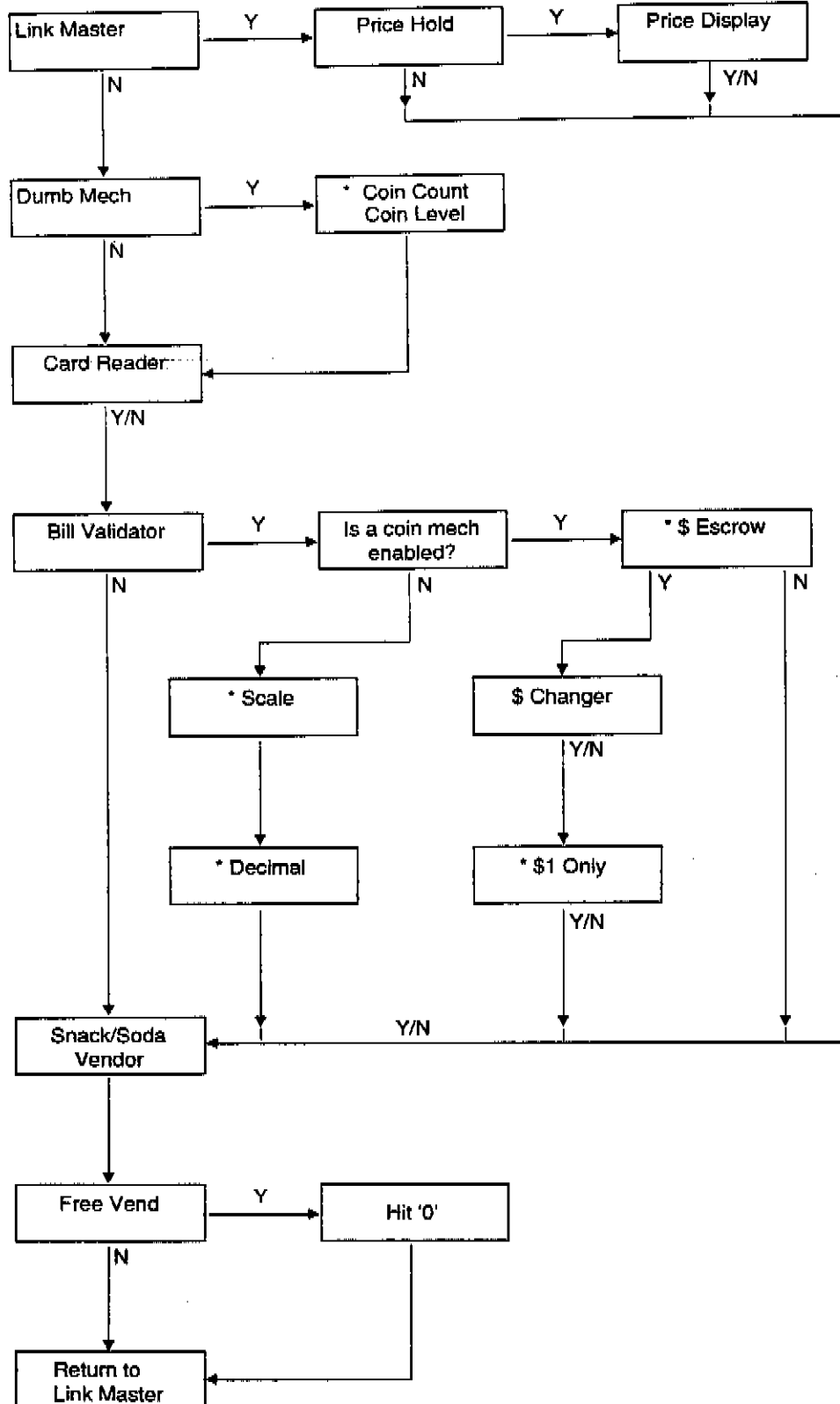

* Fig 3-2. Flow chart representing the programming steps of the Peripheral Configuration Menu. Blocks marked with an "*" indicate new functions described on page 3-6.

VI. Key 5 - Manual Peripheral Configuration

Purpose:

To configure major peripherals on the vendor. The following options are configured in this menu:

- Link Master (Executive Coin Mech)
 - Price Hold
 - Price Display
- Dumb Mech
 - Coin Count/Coin Level
- Debit Card Reader
- Bill Validator
 - \$ Escrow
 - Dollar Changer
 - \$1 Enable
 - Scale and Decimal Position
- Snack / Soda
- Free Vend

COIN COUNT/COIN LEVEL

This feature is available when a Dumb Coin Changer is selected. With **COIN COUNT** enabled, bill validator enable and the **COINS ONLY** messages are activated based on coin tube counts stored in the MIS section. With **COIN LEVEL** enabled, not only are the coin tube counts that are stored in MIS used, but the low coin level sensors in the coin changer are used as well. If the coin count for one of the coins is greater than 4 and the level sensor is blocked, the count is modified with the normal acceptance and dispensing of coins. If the level sensor should open up and the count is greater than 4, the count is automatically adjusted to 4 and a **TUBE ERROR** is recorded. On the other hand, if the count goes below 4 and the sensor is still covered up, the count will be set back to 4. Again, bill validator enable and the **COINS ONLY** messages are activated based on the coin counts; however, the counts may be modified based on the true coin levels.

SCALE/DECIMAL

A bill validator may be added without a coin changer. Because the coin changer sets the scale factor and decimal location for pricing, those items must be programmed when a coin changer is missing.

\$ ESCROW Y/N

This feature is designed to allow the use of alternate bill validators that do not have an escrow feature. Check with the bill validator manufacturer to see if the validator you wish to use conforms to the Rowe CBA-2 escrow protocol. Only set \$ ESCROW to YES if the bill validator being used has an escrow circuit. This setting does not automatically hold a bill in escrow if turned on. It only lets the controller know that the validator has an escrow circuit.

\$1 ONLY

This feature was previously called \$5 ENABLE. Because the Snack/Candy Vendor can accept up to a \$20 bill, this feature has been renamed to better describe its function. Set \$1 ONLY to YES to accept \$1 bills only and reject all others. Set \$1 ONLY to NO to accept all denominations from \$1 to \$20 based on available change in the coin changer and notes enabled in the bill validator.

Programming Instructions:

1. Press <5> on the keypad.
2. Response will be "LNK MSTR Y" or "LNK MSTR N".
3. Press <1> to toggle "Y" or "N".
4. Press <5> to proceed to the next menu option.
 - a. If "LNKMSTR" was enabled, the next menu item will be "PRC HOLD N".
 - b. If "LNK MSTR" was disabled, proceed to step 37, "SNACK/SODA".

NOTE:

If Link Master Y is selected, the coin mech must also be reconfigured. Refer to coin mech manufacturer's instructions.

The following instructions are for price hold and price display options.

5. Press <1> to toggle Y/N to enable or disable "PRC HOLD".
6. Press <5> to proceed to the next menu item.
7. If "PRC HOLD" was enabled, the next menu item will be "PRC DISP". If "PRC HOLD" is disabled, "PRC DISP" is automatically disabled.

8. To enable or disable "PRC DISP" press <1> to toggle Y/N.
9. Press <5> to proceed to the "DUMB MECH" option.
10. The display will read "DUMB MEC Y".
11. Press <1> to toggle Y/N.
12. Press <5> to save and proceed to the next option.
If "DUMB MEC Y" was selected, the next menu item will be "COIN COUNT/COIN LEVEL". If "DUMB MEC Y" was selected, go to step 15.
13. Press <1> to toggle between 'COIN COUNT' and 'COIN LEVEL'.
14. Press <5> to save and proceed to the next menu option.
15. Display will read "CARD RDR N".
16. Press <1> to toggle Y/N.
17. Press <5> to save and proceed to the next menu option.
18. Display will read "BILL VAL Y".
19. Press <1> to toggle Y/N.
20. Press <5> to proceed to the next menu item.
If the bill validator is enabled, and "DUMB MEC N" was selected, go to step 31 to set up the scale factor and decimal placement. If "DUMB MEC Y" was selected, the next menu option will be "\$ ESCROW".
21. Display will read "\$ ESCROW Y/N".
22. Press <1> to toggle Y/N.
23. Press <5> to save and proceed to the next menu option.
24. If "\$ ESCROW Y" was selected, the next option will be "\$ CHNGR N". If "\$ ESCROW N" was selected, proceed to step 37.
25. Display will read "\$ CHNGR Y/N".
26. Press <1> to toggle Y/N.
27. Press <5> to save and proceed to the next menu option.
28. Display will read "\$1 ONLY Y/N".
29. Press <1> to toggle Y/N.
30. Press <5> to save and proceed to step 37.
31. Display will read "SCALE 5".
32. Press <1> to change the scale to 1, 5, 10, 50, 100, or 500.
33. Press <5> to save and proceed to set the decimal position.
34. Display will read "DEC 0.00".
35. Press <1> to change the decimal position to .000, 000, 00.0, or 0.00.
36. Press <5> to save and proceed to the next menu option.
37. Display will read "SODA VEND" or "SNACK VEND".
38. Press <1> to toggle from "SODA VEND" to "SNACK VEND". Select "SNACK VEND".
39. Press <5> to save and proceed to the next menu.
40. The display will read "FREE VND N".
41. Press <1> to toggle Y/N.
42. If Free Vend is chosen the display will read "HIT KEY '0'". This is a safety feature that prevents the snack vendor from accidentally being placed in the free vend mode.

VII. KEY 6 - Promotional Vend Pair Programming

Purpose:

To select which items will be vended free with selected purchases when the Promotional Vend feature is enabled.

Programming Instructions:

1. Press <6> on the keypad.
2. The display will read "01 PXX FXX".
"01" represents the selected pair.
"PXX" refers to the purchased selection.
"FXX" refers to the item that will be vended free.
3. Press <1> to increment the purchase selection.
4. Press <2> to decrement the purchase selection.
5. Press <3> to increment the free selection.
6. Press <4> to decrement the free selection.
7. Press <5> to save the selection and proceed to the next pair of selections.
8. Press <0> to save the last pair entered and return to the root menu.
9. Press <RESET> to ignore the last entered pair and return to the root menu.
10. Repeat steps 1-7 to set up to five pairs.

NOTE:

Dip switch #4 on the control board must be ON to enable this feature .

VIII. KEY 7 - Point-of-Sale Message

Serial Number

Machine ID

Date/Time

Auto Lockout

Baud Rate

Purpose:

To program the point-of-sale message and the machine's serial and ID numbers.

Programming Instructions:

1. Press <7> on the keypad.
2. Press <1> to program the POS Message.
Press <2> to program the Serial Number.
Press <3> to program the Machine ID number.
Press <4> to set the date.
Press <5> to set the time and the day of the week.
Press <6> to program the Automatic Lockout Feature.
Press <7> to set the date format.
Press <8> to set the printer baud rate.

A. Programming the POS Message

1. The display will read "P>_ A". The 'P>' is the prompt to enter the message. The dash is where the letters will appear as they are placed in the POS message. The 'A' at the right side of the display is the character that will be placed in the message. Programmable characters are: uppercase A-Z, 0-9, space, # and \$.
2. Erase previous message
 - a. Press <9>
 - b. Press <0>
3. Press <7> to return to the POS menu.
4. Press <1> to begin programming message.
5. Use the following keys to program the POS message:
 - <1> Move cursor position to the right.
 - <2> Move cursor position to the left.

- <3> Increment character.
- <4> Decrement character.
- <5> Place character in message.
- <9> First of two keystrokes required to delete to the end of the message.
The <0> must be pressed to complete this function.
- <0> Save message and exit to root menu.
- <RESET> Exit to the root menu with no changes saved.

6. Press <3> until the column on the right scrolls to the desired letter. Hold the key down to scroll more quickly.
7. Press <5> to enter the letter.
8. Repeat step 6 until the message is complete. Use the other control keys as needed.
9. Press <0> to save the message and return to the root menu.

B. Programming the Serial Number

1. Press <7> on the keypad.
2. Press <2> to get to the serial number programming mode.
3. Use the same control keys used to program the POS message.
4. Program the number.
5. Press <0> to save the message and return to the root menu.

C. Programming the ID Number

1. Press <7> on the keypad.
2. Press <3> to get to the ID programming mode.
3. Use the same control keys used to program the POS message and the serial number to program the ID number.
4. Program the ID number.
5. Press <0> to save the message and return to the root menu.

D. Programming the Date

1. Press <7> on the keypad.
2. Press <4> to get to the date programming mode. The date format will be shown before the date is displayed.
3. Press <1> to increase the MM field.
Press <2> to decrease the MM field.
4. Press <3> to increase the DD field.
Press <4> to decrease the DD field.

5. Press <7> to increase the YY field.
Press <8> to decrease the YY field.
6. When the correct date is showing in the display, press <0> to save and exit the date programming mode.
7. Press <RESET> to exit without saving the new date.

E. Programming the Time and Day

1. Press <7> on the keypad.
2. Press <5> to get to the time and day programming mode. The time and day will be displayed as "HH.MM DAY".
3. Press <1> to increase the HH field:
Press <2> to decrease the HH field.
4. Press <3> to increase the MM field.
Press <4> to decrease the MM field.
5. Press <7> to increase the DAY field.
Press <8> to decrease the DAY field.
6. When the correct time and day is showing in the display, press <0> to save and exit the time and day programming mode.
7. Press <RESET> to exit without saving the new date.

F. Programming the Lockout Feature

1. Press <7> on the keypad.
2. Press <6> to get to the lockout programming mode. The display will show "PGM X DAY", where 'X' is a number from 0 to 9 and 'DAY' is a specific day of the week, or 'WKDS', indicating work days Monday through Friday, or 'WEEK', indicating every day of the week, or 'OFF,' indicating that this program entry is not used.
3. Press <6> to change the program event number. There are 10 programmable events, numbered 0 to 9.
4. Press <1> or <2> to change the DAY.
5. Press <5> to display the ON time for the program event. The display will show "ON HH.MM", where 'ON' indicates the time 'HH.MM' that the machine will be disabled.
6. Press <1> to increment the hours HH.
Press <2> to decrement the hours HH.
7. Press <3> to increment the minutes MM.
Press <4> to decrement the minutes MM.
8. Press <5> to display the OFF time for the

program event. The display will show "OFF HH.MM", where 'OFF' indicates the time 'HH.MM' that the machine will go back into service. Be sure the OFF time is later than the ON time.

9. Follow steps 6 and 7 to set the OFF time.
10. Follow steps 3 through 8 to set up other programmed lockout days and times.
11. Press <7> to set the displayed event OFF and to reset the ON and OFF times to '00.00'.
12. Press <RESET> to exit the lockout programming mode. All settings are automatically saved as they are made.

G. Setting the Date Format

1. Press <7> on the keypad.
2. Press <7> again to get to the date format mode.
3. Press <1> to toggle the date format between MM/DD/YY and DD/MM/YY.
4. Press <0> to save the new date format and exit.
5. Press <RESET> to exit the date format mode without saving any changes.

H. Programming the Printer Baud Rate

1. Press <7> on the keypad.
2. Press <8> to get to the baud rate mode.
3. Press <1> to change the baud rate.
4. Press <0> to save the new baud rate and exit.
5. Press <RESET> to exit the baud rate mode without saving any changes.

IX. KEY 8 - MIS Display and Printer Communications

Purpose:

To retrieve MIS information. The controller will attempt to send MIS information to the printer. If there is not a printer present or powered-up, the controller will display the information, line by line, on the customer display.

Programming Instructions:

1. Press <8> on the keypad. If the printer is present, all the information will be printed; proceed to step 5. If the printer is not present, follow the steps below to display the MIS data on the message center.

2. Response will be "SERIAL NUMBER" (the first line of MIS data).
3. Press <0> to proceed to the next line of MIS data.
4. Repeat step three until you reach the end of the MIS data. The last line will prompt the operator, "CLR MIS N".
5. Press <1> to toggle Y/N.
6. Press <RESET> at any time to return to the root menu.

X. Key 9 - Security Code Programming

Purpose:

To protect specific menus from unauthorized access. If the security feature is enabled, the operator must select which menus are protected by the security feature. Menus that are protected by the security feature will only be available if the Service Mode is accessed by entering the security code on the keypad. Menus that are not protected by the security feature will be accessible when the service mode is accessed by pressing the "MODE" button on the controller.

Programming Instructions:

1. Press <9> on the keypad.
2. Response will be "ENTER CODE".
3. Enter a four digit security code.
4. The code number will flash four times.
5. The display will read "SECURE OFF/ON".
6. Press <1> to toggle Off/On.
7. Press <5> to step through each menu.
8. Press <1> to toggle Off/On.

NOTE:

This feature must be set to ON to prevent unauthorized access or code changes. Menu 9 must also be set to ON.

9. Press <0> to save the new security status and return to the root menu.
10. Press <RESET> to exit this function without saving.

XI. KEY 0 - Motor Count and Test Vend

Purpose:

To test all of the motors in the machine to make sure they are working. There are three options available in this menu. Key 1 is motor count. Key 2 is the individual test vend option. Key 3 will test all the motors in the machine.

Programming Instructions:

A. Motor Count

1. Press <0> to get to the motor function menu.
2. The display will read "MTR FUNCT?".
3. Press <1> to run motor count display.
4. Display will be "XX". *XX represents the number of motors detected.*
5. The display will return to "MTR FUNCT?".

B. Test Vend Individual Motors

1. Press <0> on the keypad.
2. Display will read "MTR FUNCT?".
3. Press <2> on the keypad.
4. Display will read "SELECTION".
5. Enter 2 digit selection.
6. Display will read "AA XX.XX".
AA = Selection Number.
XX.XX = Selection Price.
7. The machine will test vend selection.
8. The display will read "MOTOR FUNCTION?" after the individual test vend is completed.

C. Test Vend All Motors

1. Press <0> on the keypad.
2. Display will read "MTR FUNCT?".
3. Press <3> on the keypad.
4. The machine will test vend all connected motors in a shelf by shelf order.
5. Display will read "VEND XX".
XX represents total motors vended.
6. The display returns to "MTR FUNCT?".

Section 4

Table of Contents

Troubleshooting Procedures	4-2
Locating and Replacing Defective Motors	4-2
Refrigeration System	4-3
Refrigeration System Wiring Diagram	4-4
Troubleshooting Charts	
Error Messages	4-5
Problem/Solution	4-6
Bill Acceptor	4-9
Interconnect Block Wiring Diagram	4-11
15 Pin Coin Mech Socket	4-12

Section 4

Troubleshooting

INTRODUCTION

This section contains Troubleshooting Charts, a Block Wiring Diagram, and an Interconnect Block Diagram. The first chart lists the error messages that may be displayed while in the diagnostic mode. The second lists possible problems and suggested solutions.

Clear Errors

Diagnostic error messages are cleared by pressing <RESET> while in the diagnostic mode. Following a diagnostic reset, "NO ERRORS" will be displayed for 1 second. *Clearing errors does not correct the problems indicated by the error messages, it only removes the message from the machine's memory.*

Price Checksum

A checksum is made on the selection price before attempting a vend. If an error occurs with the price, the selection is flagged as being bad and "SELECT OTHER ITEM" is displayed. The selection will also be marked as "CHK PRICES=" in the diagnostic mode. Error messages will be displayed after all "CHK PRICES."

TROUBLESHOOTING PROCEDURES

It is important to troubleshoot logically. Many malfunctions are caused by minor defects such as loose connections or dirty contacts. Ensure that the vendor is connected to a good power source and follow the checklist at right before replacing any parts.

Voltage and Polarity Check

With a voltmeter, check for proper voltage, polarity and good ground using the following example:



Check List

- Check circuit breakers. These are located on the Transformer Box assembly at the bottom left hand side of the cabinet.
- Check to ensure that the Main power switch is ON - located directly above the Transformer Box.
- Check to ensure that all plugs are firmly seated in their receptacles.
- Check to ensure that connector pins are not bent, broken or pushed through the back of the connector or receptacle when mated.
- Check to ensure that wires are not broken at connector pins.

Locating and Replacing Defective Motors

1. Open the main door and check the display for "OVER CRNT=" or "HOME FAIL=" errors.
2. Record all the selection numbers that follow these error messages.
3. Check all disabled selection helixes for improper loading, jams, etc.
4. Run a single selection motor test on each disabled selection by following the instructions in Motor Count and Test Vend on page 3-10.
5. If the motor fails to operate, first check applicable wires and connectors to the motor. Second, replace defective motor assembly as follows:
 - a. Remove helix.
 - b. Insert hub removal tool (593-902) and pull hub off.
 - c. Compress motor retaining tabs and remove motor.

6. Run a test vend on repaired selections.
7. After all repairs are made, press <RESET> while viewing the error messages to clear all faults.

REFRIGERATION SYSTEM (OPTIONAL)

If the refrigeration system compressor is inoperative, perform the following checks before replacing the unit. Be sure to hold the Refrigeration Interlock Switch closed when making the operational checks.

1. Measure the line voltage. If it is below 105 volts, the compressor may fail to start or it may run hot.
2. If line voltage is correct, check automatic control thermostat operation by connecting a jumper wire across the terminal with power disconnected.
3. The Start Capacitor, Run Capacitor, and Start Relay are best tested by substituting them with known good components. This way there can be no doubt of test results.
4. Check Thermal Overload for continuity.
5. With motor leads disconnected from circuits, check compressor motor windings with Volt/Ohm meter set on R x 1 scale.
(Readings \pm 10%)
Common to Start 32 Ohms
Common to Run 7 Ohms
Start to Run 38 Ohms*
* Measured at ambient room temperature.
6. Check for grounded winding with Volt/Ohm meter from Start Capacitor to metal casing and Run Capacitor to metal casing. There should be no continuity. If there is, replace the compressor.

Compressor Circuit

The Compressor circuit in the 595 Air Cooled unit is a Permanent Split Capacitor Start Motor. This utilizes a single Start Capacitor with a value of 53/64 μ FD. There is a Start Relay Mounted on the Compressor; this is a Current Type Relay. When the Current in the Run Winding is above a certain level, the Coil energizes. When the Coil energizes, the normally open contact closes, connecting the

Start Capacitor to the Start Winding of the motor. The Start Relay @ Start Capacitor circuit causes a high starting torque to accelerate the Compressor Rotor Shaft to full speed. When the Compressor Rotor Shaft is at its running speed, the current through the Run Winding will drop to the normal Run Current, allowing the Coil of the Start Relay to de-energize. When the Coil de-energizes, the contact will open and break the Starting Circuit. The motor will continue to run via the current through the Run Winding. If the Run Winding current rises (i.e., the motor stops or stalls), the Start Relay Coil will again energize and the cycle above repeats itself.

Refrigeration Removal Instructions

1. Unplug the Snack/Candy vendor from wall.
2. Unplug the Refrigeration Unit.
3. Remove the four (4) screws securing the Door switch Bracket. Remove the wires from the switch.
4. Remove the Cash Box.
5. Remove the two (2) square Phillips screws securing the Cash Box Bracket.
6. Remove the four (4) screws holding the Stop Rod Bracket. Swing the Stop Rod out of way.
7. Remove the five (5) square Phillips screws securing the Condenser Intake Cover.
8. Remove the four (4) square Phillips screws securing the Screen.
9. Remove the two (2) screws securing the Refrigeration Unit hold-down bracket into the Base.
10. Remove the bottom shelf.
11. Reach into access hole in the deck and with two fingers, unscrew the Transition Duct to Refrigeration thumb screw.
12. The refrigeration unit is now ready to be removed.
13. To install, reverse the above procedures.

REFRIGERATION SYSTEM WIRING DIAGRAM

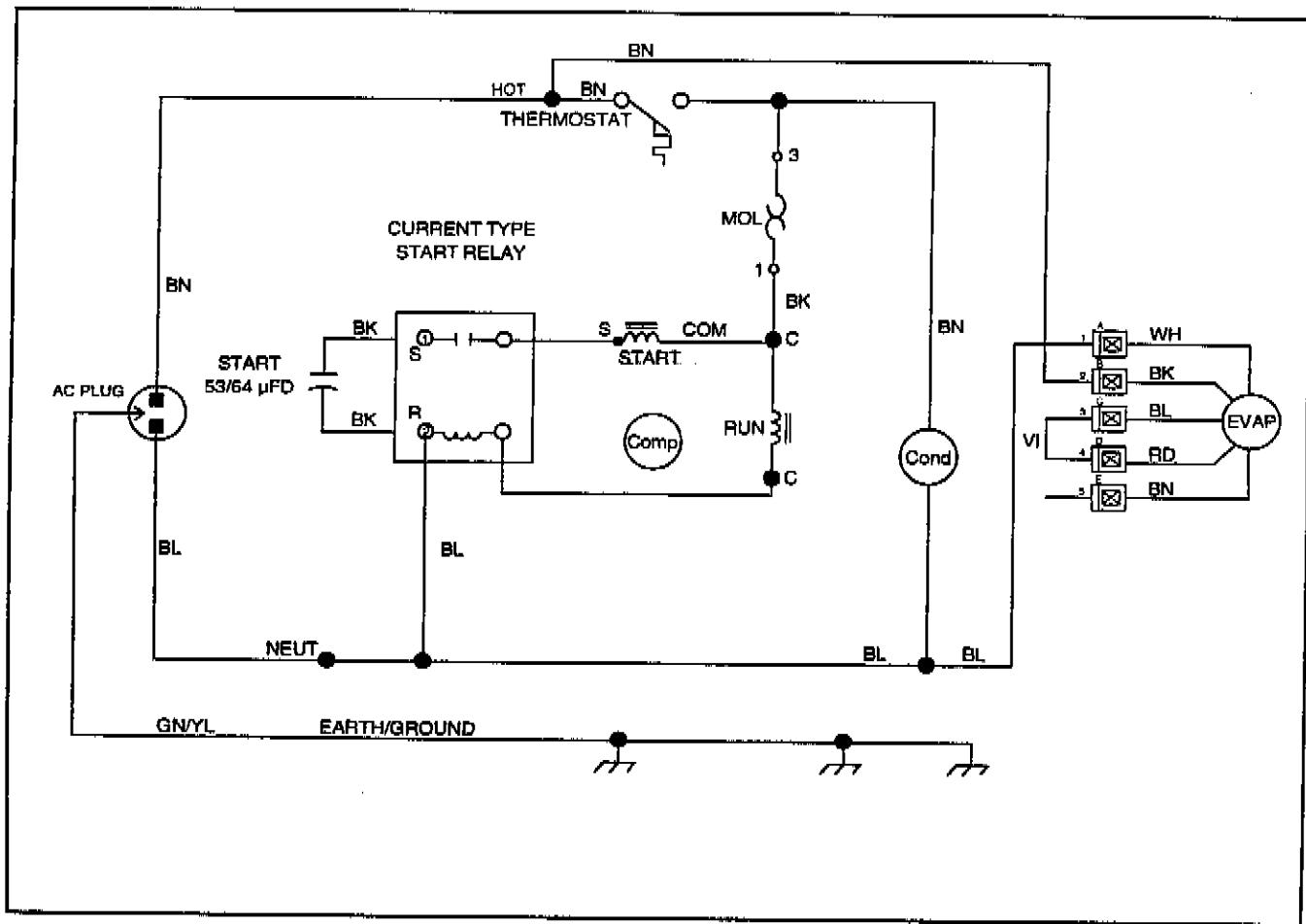

Figure 4-1. Refrigeration System Wiring Diagram

CAUTION !

Protective eye wear must be worn when testing refrigeration systems. This system is charged with 14 oz. of R-12 refrigerant. Repairs should be performed by technicians trained and experienced in refrigeration troubleshooting and safety procedures.

Troubleshooting Chart 4-1 Error Messages

ERROR MESSAGE	PROBABLE CAUSE	SOLUTION
"OVER CRNT="	Shorted or jammed motor	Follow instructions on page 4-3 for locating and replacing defective motors.
"HOME FAIL="	Motor did not complete full rotation or leave the home position	Follow instructions on page 4-3 for locating and replacing defective motors.
"COIN JAM"	Coin jammed in coin mech	Clear jammed coin
"BAD SENSOR"	Defective Coin Mech level sensor	Replace
"CHGR PWRUP"	Coin mech not sending power-up message	Check that coin mech is connected Check Peripheral Configuration
	Defective Coin Mech	Replace
"CARD PWRUP"	Card reader not sending power-up message	Check that card reader is connected Check Peripheral Configuration
	Defective Card Reader	Replace
"LNK PWRUP"	European Executive Coin Mech not sending power-up message	Check that Executive Mech is connected Check Peripheral Configuration
	Defective Executive Coin Mech	Replace
"BILL ERROR"	Faulty credit messages from Bill Acceptor	Check BA connection
	Defective Bill Acceptor	Check Peripheral Configuration Replace
"MACHINE OUT OF ORDER" shows on display when door closed	Valid start-up message not received from configured peripheral	Check for error message and follow steps in the troubleshooting chart for that error message.
		Check Peripheral Configuration.
"CHK PRICES="	Selection contains corrupted price.	Reprice selection.
	EPROM Version -5 will scan all vend motors continuously even while in the service mode. When a shelf is pulled out, those selections will display as "CHK PRICES="	Reinstall shelf.

Troubleshooting Chart 4-2 Problem/Solution

PROBLEM	PROBABLE CAUSE	SOLUTION
No Indicator lights in machine	No AC power into machine	Check P1 of Controller 24 VAC @ pins 1 and 2 120 VAC @ pins 4 and 6 Check circuit breaker in transformer assembly.
Display does not light	No power to display	Check +5 VDC at display @ pins 12 to 14 Check +24 VDC at display @ pins 11 to 12
No Display	Loose or defective Harness	Check that P6 of Controller is seated
Does not accept coins	Coin Mech not reset or not receiving coin acceptance signal	Check connection @ P6 on Controller and P1 on Display Check that Accept Enable is low @ pins 6 to 2 on Coin Mech Socket Check +5 VDC @ pin 1 to 2 at Coin Mech Socket Check +120 VPDC @ pin 10 to 12 at Coin Mech Socket Check +24 VPDC @ pin 13 to 15 at Coin Mech Socket
	Check Coin Mech Manufacturer's Instructions	
	Machine not level	Clear coin track
	Defective Coin Mech	Level cabinet
Does not accept bills	Bill Acceptor not receiving bill acceptance signal	Replace Insufficient change in coin tubes Check Coin Mech tube amounts in program Mode 1 Check peripheral configuration. Check for Accept Enable held low @ P4 pins 1 to 7 on Controller Check power to Bill Validator 120 VAC @ AC connector
	Credit message not received from	Check +5 VDC @ P4 pins 4 to 7 on Controller

Troubleshooting Chart 4-2 (Problem/Solution)

PROBLEM	PROBABLE CAUSE	SOLUTION
Two motors run simultaneously	Defective Controller	Replace
	Pinched or shorted wires in wire harness	Repair or replace wire harness.
Fluorescent light does not light	Defective lights or starter	Replace
Cannot buy from row 4	No sale switch ON	Set switch to OFF
	Controller P9 pin 1 and 2 shorted	Replace Controller
Fan does not run	Defective harness	Check for 120 VAC @ fan connector
	Defective fan	Replace
Display always shows "SYSTEM	Defective door switch	Replace
	Door switch not activated when the door is closed	Adjust switch bracket until activation occurs

Troubleshooting Chart 4-3 Bill Acceptor

ERROR MESSAGE	PROBABLE CAUSE	SOLUTION
Bill Acceptor rejects a large number of valid bills. The BA STATUS LED will flash one or more times to indicate the cause of the reject.	BA STATUS LED flashes once after rejecting Bill.	Defective V1 or V4 cell. Defective UBA Unit.
	BA STATUS LED flashes twice or three times after rejecting Bill.	Twice indicates a defective V2 cell. Three times indicates a defective V3 cell or an object lodged in the transport.
	BA STATUS LED flashes four times after rejecting Bill.	Object lodged in Transport. Binding Anti-pull back lever. Defective lower harness and cell assembly. Defective UBA Unit.
	BA STATUS LED flashes five times after rejecting Bill.	Defective magnetic head or Transport. Defective UBA Unit.
	BA STATUS LED flashes six times after rejecting Bill.	Bill denomination has not been enabled
Transport motor does not start when a bill is inserted.	BA STATUS LED flashes eight times after rejecting Bill.	UBA was commanded to return the bill held in escrow.
	Power LED on UBA Unit not lit.	Problem in Power Supply. Defective harness to UBA Unit.
	Transport does not start, but clicking sound is heard in UBA Unit.	Object jammed in Transport. Defective UBA Unit.
	No sound or any other indication that Transport is trying to run.	Defective V1 cell. Defective UBA Unit.
Bills jam frequently.	BA STATUS LED is blinking.	Defective Main Controller. UBA is not operational due to a "Fault" condition (See "UBA in shutdown").
	Any bill transporting failure.	Anti-pull back lever not operating freely. Bill pressure roller binding. Transport inlet or track surfaces contain projections, rough spots or dirt. Transport belts out of adjustment or dirty. Transport belts not centered on rollers. Transport upper input roller does not move up and down freely. Defective Power Supply.

Troubleshooting Chart 4-3 Bill Acceptor

PROBLEM	PROBABLE CAUSE	SOLUTION
UBA in SHUTDOWN In this state, the BA Status LED will flash ON for 1 second and then flash one or more times. The number of flashes indicates the cause of the shutdown.	BA STATUS LED flashes once.	Object in Transport covering V1 cell. Defective UBA Unit.
	BA STATUS LED flashes 3 times.	Object covering V3 cell. Defective lower harness and cell assembly. Defective UBA unit.
	BA STATUS LED flashes 4 times.	Object in Transport Unit activating anti-pull back lever. Defective lower harness and cell assembly.
	BA STATUS LED flashes 5 times.	Defective UBA Unit.
	BA STATUS LED flashes 7 times.	Bill Box full. Bill Box jammed in "off home" position. Bill Box home switch out of adjustment. Defective Bill Box.
		Defective UBA Unit.
	Motor speed could not be adjusted. Incorrect belt tension. Defective drive motor. Defective UBA Unit.	

Interconnect Block Diagram

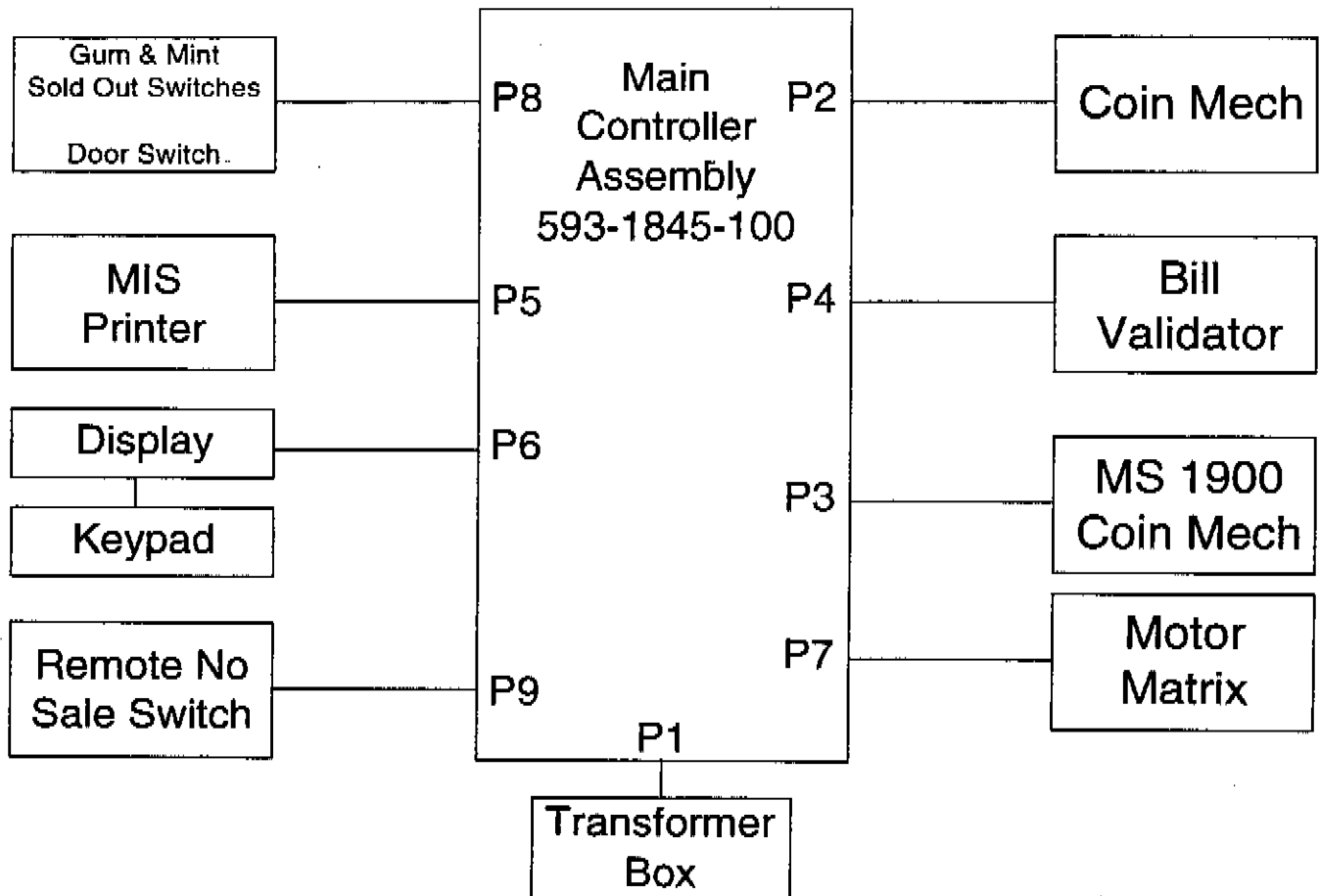

Figure 4-2. Block Diagram

15 Pin Coin Mech Socket

Coin Mechanisms

120V Models - 12 Pin

MARS TRC-6000
COINCO 9300L

24V Models - 15 Pin ONLY

MARS TRC-6010-XV
COINCO 9302LF
MAKA USPX

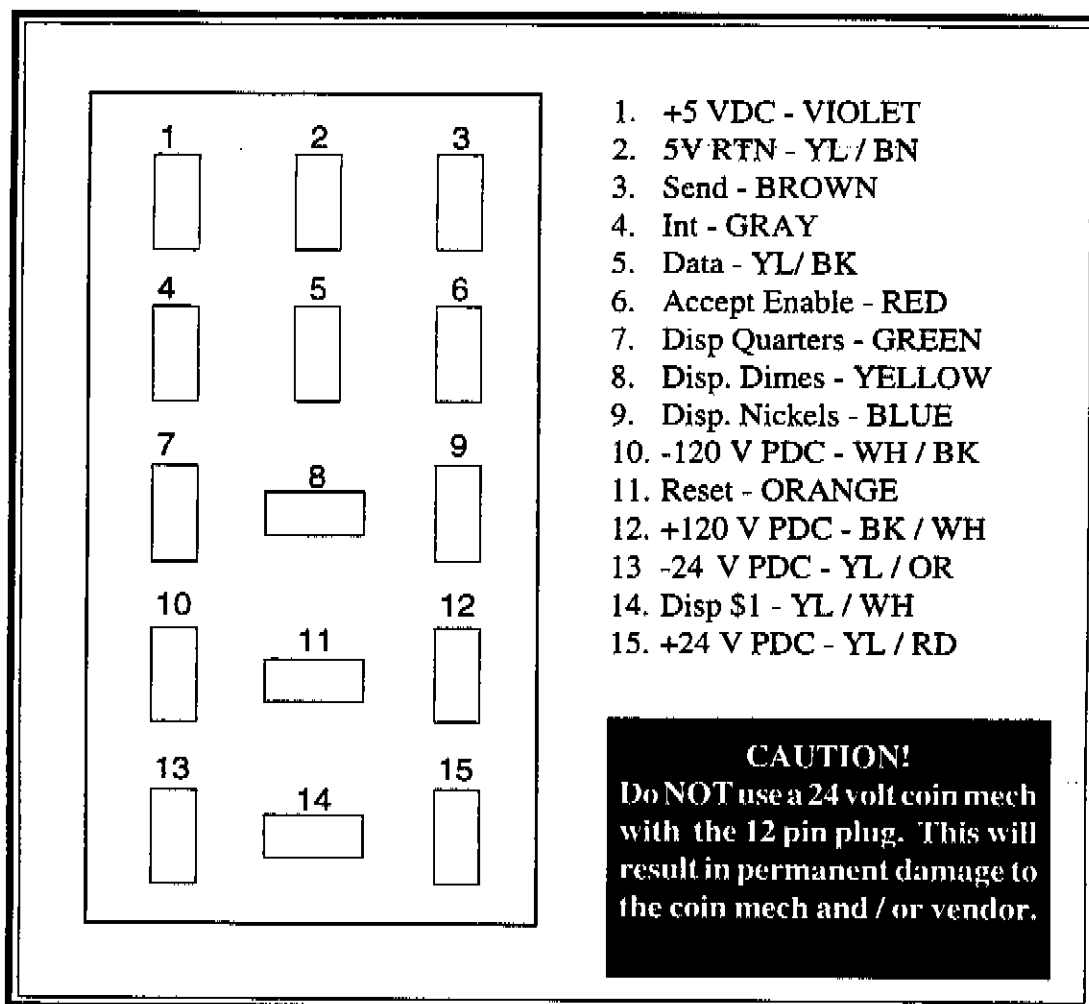
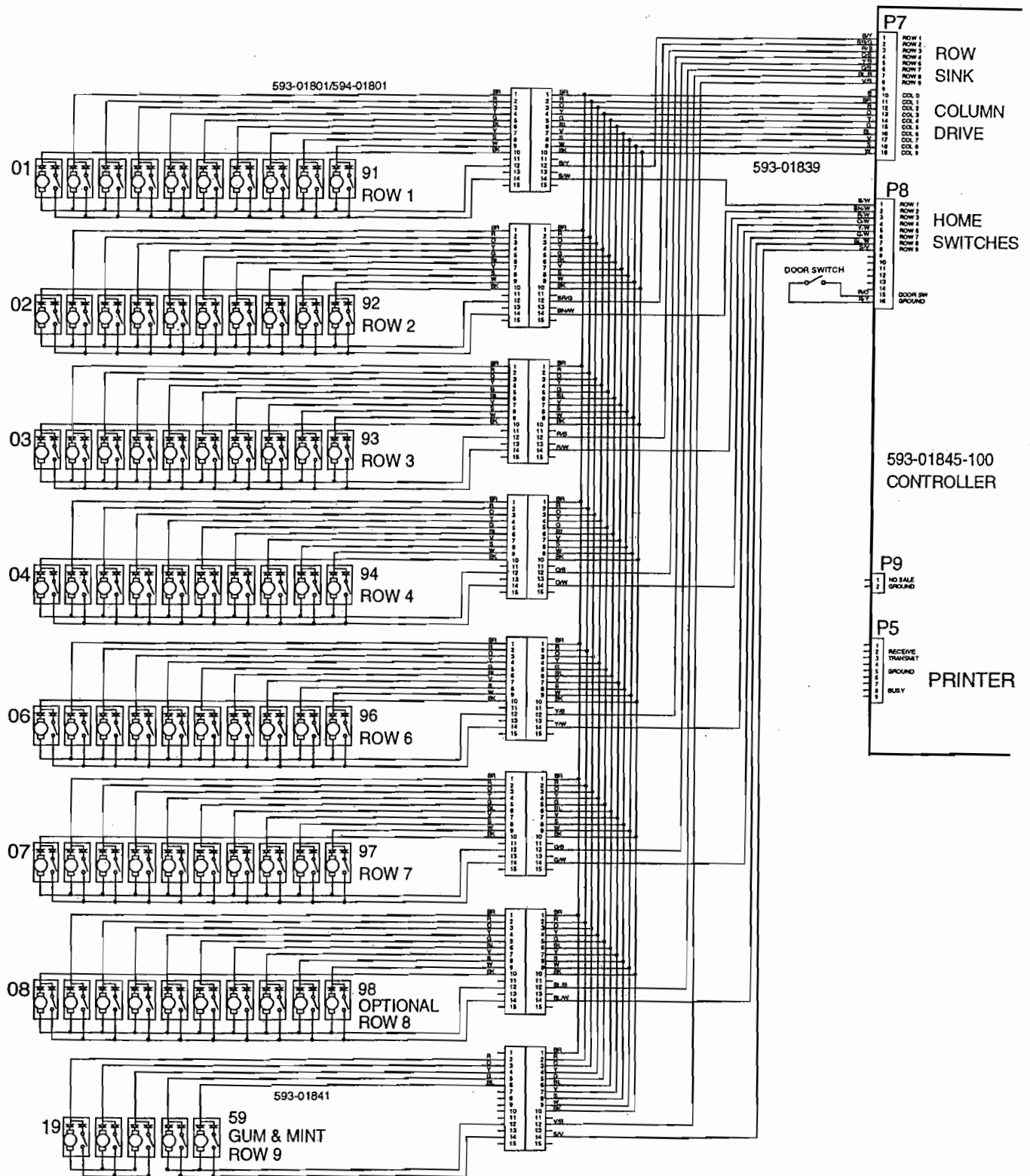

Figure 4-3. Coin Mech Socket



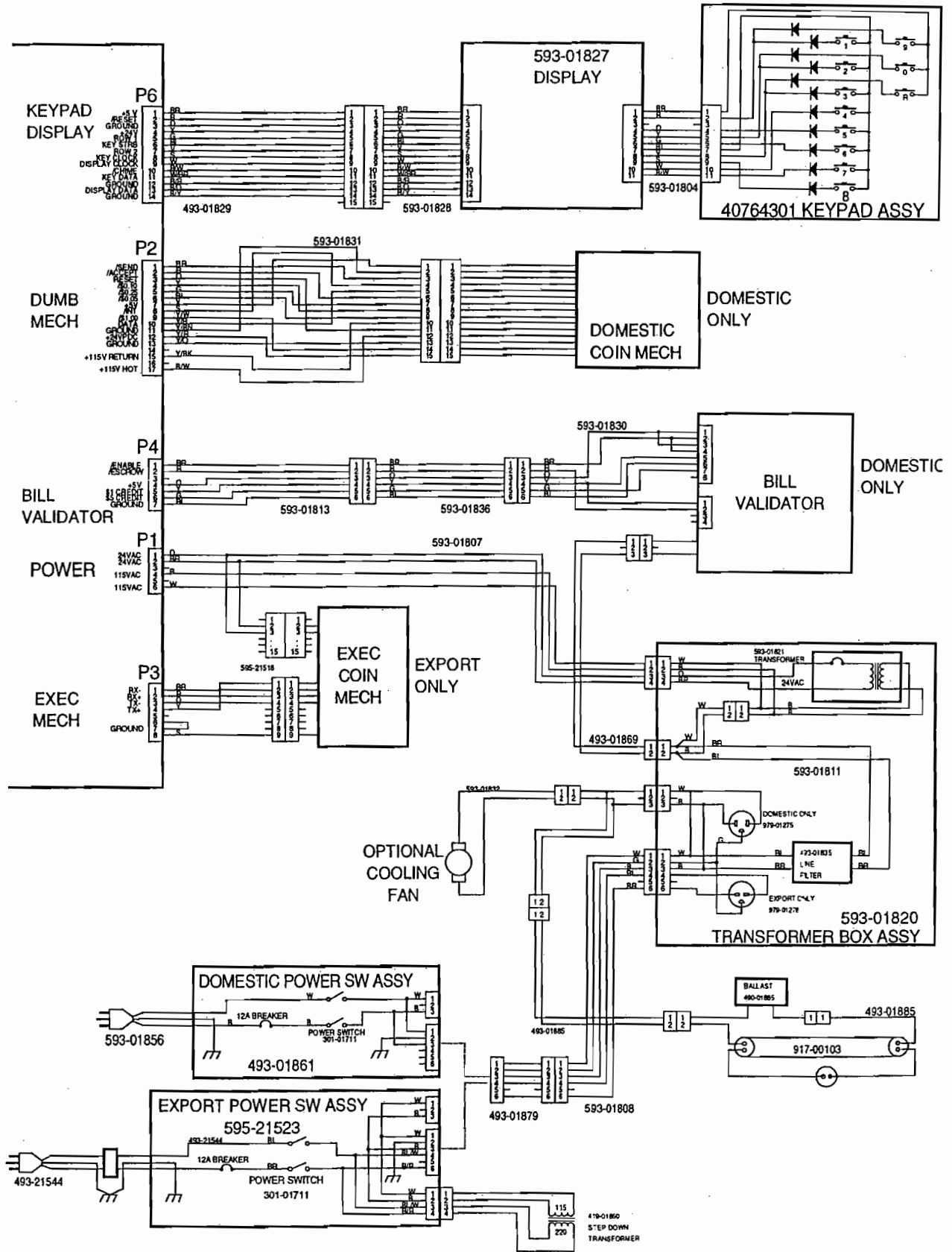
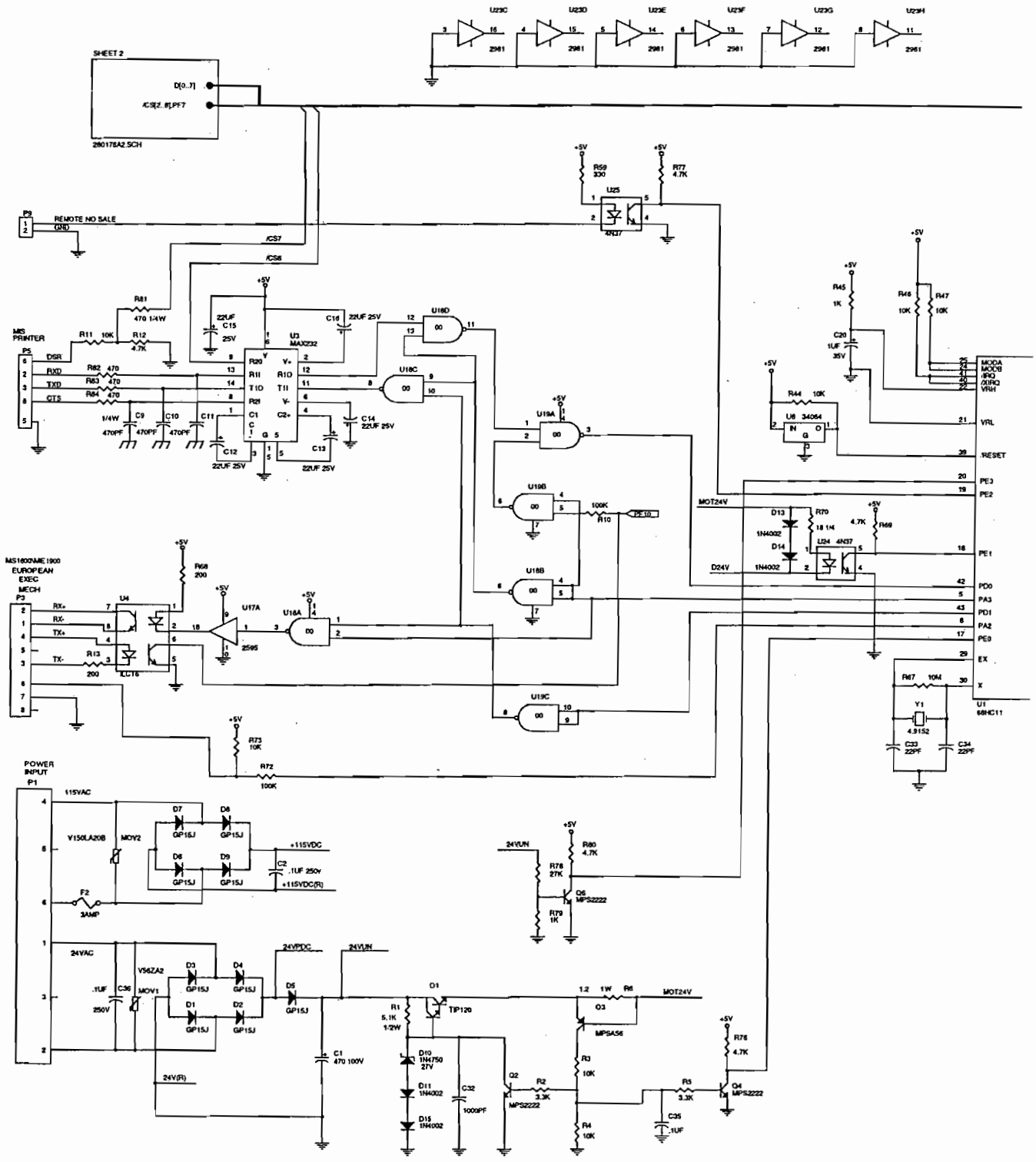
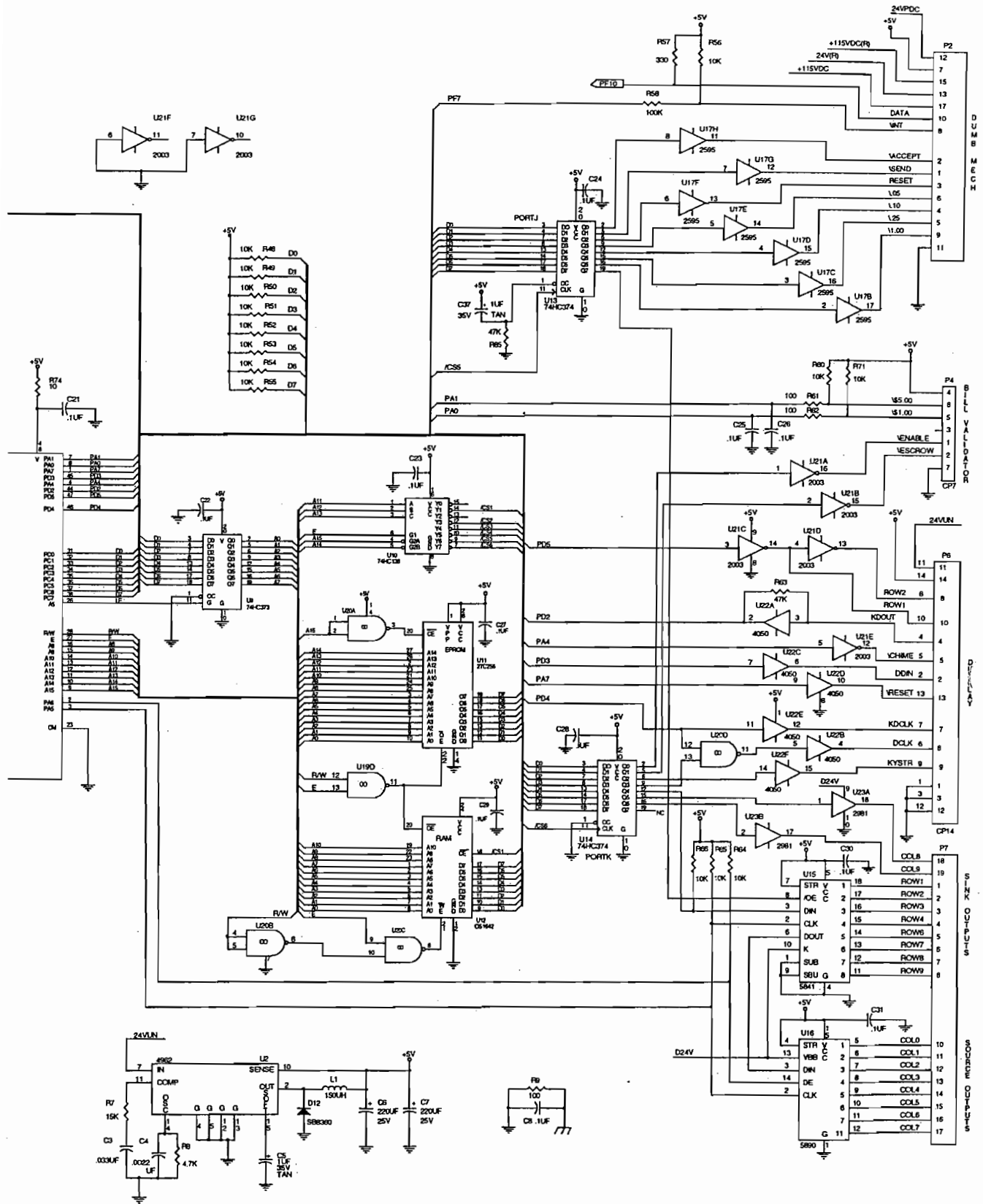
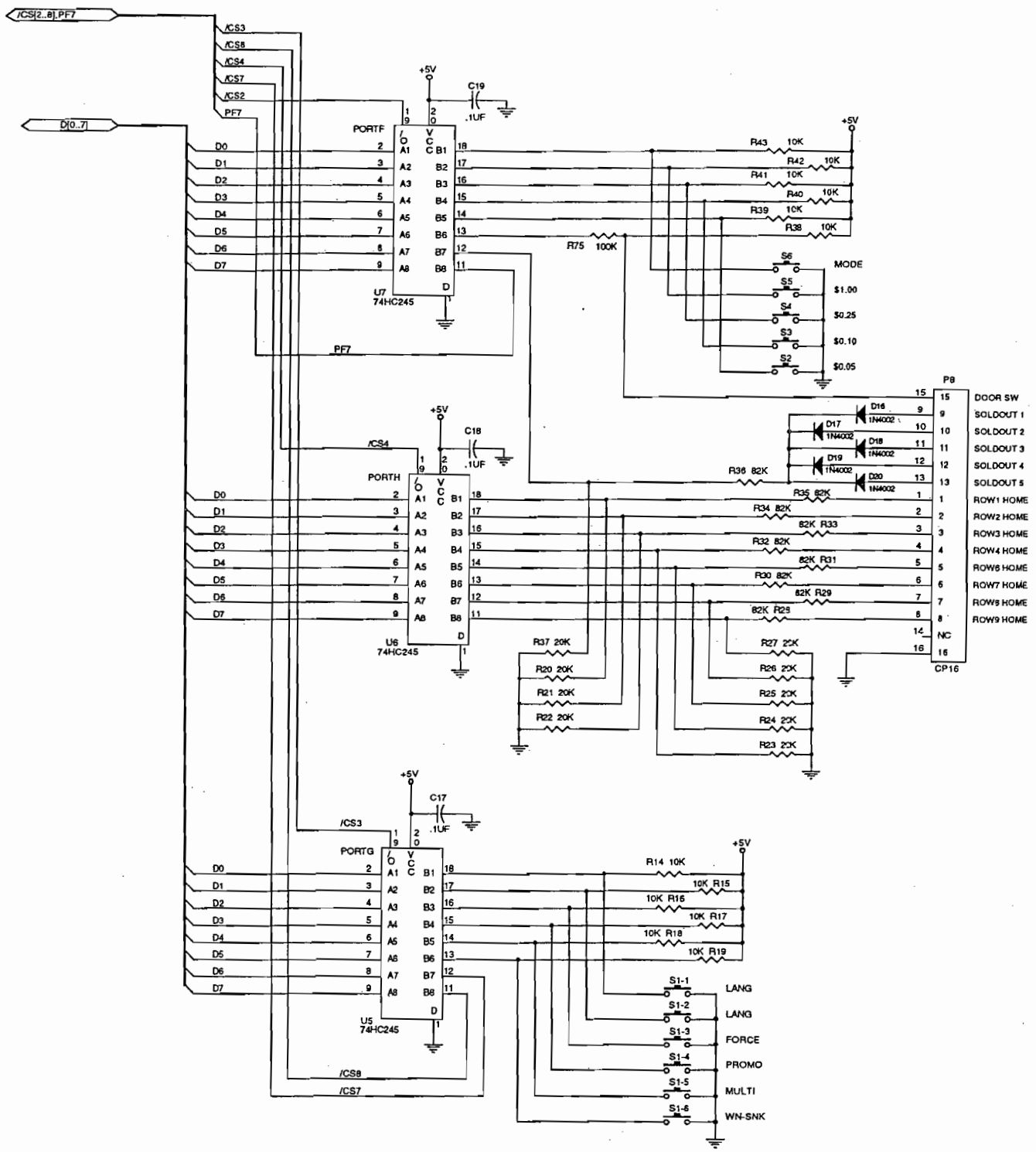

Figure 4-4. 5900 System Schematic





For Equivalent Engineering Drawing See 90059311
Figure 4-5. 5900 Controller Schematic, Sheet 1



For Equivalent Engineering Drawing See 90059311
Figure 4-5. 5900 Controller Schematic, Sheet 2
 900-59303 H

This page intentionally left blank.

Section 5

Maintenance

INTRODUCTION

This section contains information on proper cleaning procedures, as well as instructions on how to remove and replace key vendor components

CLEANING

To project the best selling image to the customer, and to prolong the beauty of the vendor, it is important to keep the Snack Vendor clean.

1. The display window should be cleaned inside and out with any good glass cleaner, using clean, soft cloths or paper towels.
2. Painted metal and vinyl surfaces can be cleaned with warm water and mild detergent, paying particular attention to the delivery box, inside and out. **DO NOT** get water on electrical components.
3. Use suitable metal cleaner for the brushed and polished metal located on front door.
4. Cleaning the shelves is easily accomplished with helix coils and adjustable walls removed (See Removal and Replacement below).
5. Check regularly to make sure that coin paths are clean and dry through the coin mechanism.

REMOVAL AND REPLACEMENT

Single Selection Helix

Helix replacement is easily accomplished without removing the shelf from the vendor. On 10-selection shelves, the adjustable wall must be removed from the compartment. Swing the adjustable wall forward as far as it will go and lift at the two pivot points. Then remove the helix as follows:

1. Pull the shelf out and let it tilt to its service position.

2. Grasp the front of the helix coil and lift straight up. This will release the helix from the helix hub at the rear of the shelf and the helix will be free in your hand.
3. To replace the helix, make sure that the helix tip at the rear is pointing downward into the gap in helix hub. Drop the helix into the compartment. Push the bottom coil of the helix rearward & snap it into the detente at the bottom of the hub.

Dual Selection Helix

1. Pull the shelf out and let it tilt in its service position.
2. If the shelf is equipped with adjustable walls, remove by swinging the adjustable wall forward as far as it will move then lift upwards.
3. Right Side Helix - Grasp the front section of the helix spiral and lift up approximately 3 to 5 inches. Turn the helix clockwise until it snaps loose from the helix hub.

NOTE:

The right side main helix is larger than its left side counterpart.

4. Left Side Helix - Grasp the front section of the helix spiral and lift up approximately 3 to 5 inches. Turn the helix counterclockwise until it snaps loose from the helix hub.
5. Install the right and left side helix as follows:
 - a. Right Side Helix - Insert the helix end into the hub slot, then push in and twist the helix counter clockwise.
 - b. Left Side Helix - Insert the helix end into the hub slot then push in and twist clockwise
6. If applicable, reinstall the adjustable wall.

Shelf Removal

Shelf removal in the Rowe Snack/Candy Vendor is an easy operation. Remove the shelf as follows:

1. Carefully pull the shelf out to a normal service position (See Figure 5-2).
2. Lift the front of the shelf and continue to pull forward, making sure that the retaining studs clear the gap in the shelf supports (See Figure 5-3). Continue pulling the shelf forward until it stops.
3. Lower the front end of the shelf so that it will hang vertically in front of the machine (See Figure 5-4). Lower shelves will not hang vertically.
4. Grasp the sides of the shelf and lift and out.

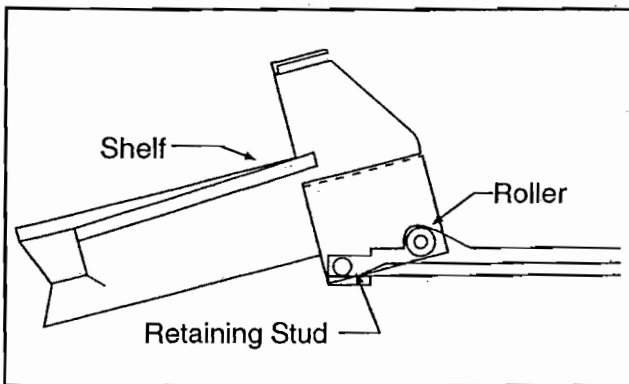

Fig. 5-1
Normal Service Position

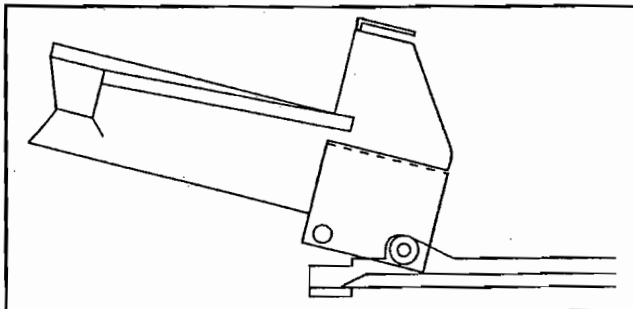

Fig. 5-2
Shelf Removal Primary Position

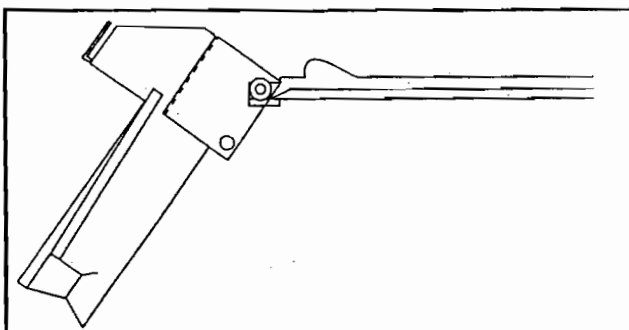

Fig. 5-3
Shelf Removal Final Position

Drive Motor

The 5900 Snack/Candy Vendor uses a high RPM DC motor. The DC motor has a high starting torque and should provide long, reliable life.

CAUTION!

DO NOT try to turn the motors by hand. Damage to the motor will result. Allow the machine to home the motors.

Gum and Mint Unit Removal

1. Pull out and remove the shelf above the gum and mint assembly.
2. Remove the left shroud.
3. Remove the left and right (white) nylon shelf guides.
4. Pull the gum and mint release levers forward and slide the shelf out to the stop position.
5. Disconnect the spring overtravel prevention bracket.
6. Shift the shelf to left and pull it out.
7. To reassemble, reverse this procedure.

Sliding Panel removal

1. Pull the sliding panel assembly all the way forward until it stops.
2. Disconnect the electrical connections to the main cabinet harness.
3. Loosen, but do not remove, the four screws

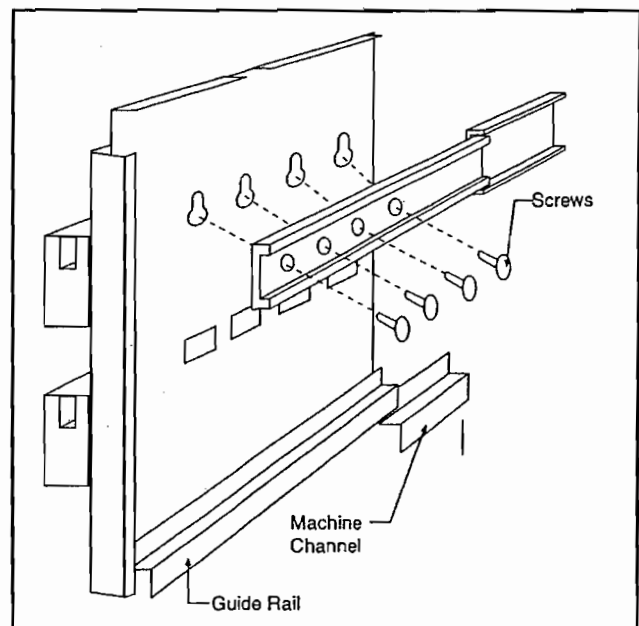

Figure 5-4
Sliding panel removal

- holding the sliding panel assembly to the slide rail assembly.
4. Carefully lift the sliding panel free of the slide rail assembly.
 5. To reinstall the sliding panel, insert the guide rail on the bottom of the panel into the machine channel secured to the cabinet.
 6. Tilt the panel to the vertical position allowing the anchoring screw heads to enter the keyhole slots.
 7. Push the panel downward until the anchoring screws are firmly seated in the keyhole slots. Tighten the screws.
 8. Reconnect all electrical harnesses and test vend for proper operation.

Selector Button Assembly Removal

The selector button assembly in the snack vendor is a sturdy, reliable assembly developed and constantly improved over many years. The buttons exposed to the public are high impact plastic nested to bases soldered into an extremely reliable P.C. Board.

Should it ever be necessary to replace this assembly or any of its parts, proceed as follows:

1. Remove the selector cover.
2. Disconnect the cable.
3. Remove the 4 mounting screws.

NOTE:

Do not remove the screws that mount the P.C. board.

4. Remove assembly.
5. To install, reverse this procedure.

Helix Hub / Motor Removal

1. Turn the power OFF.
2. Slide the shelf forward, lift the shelf upward and out. Let the shelf hang down.
3. Locate the hub removal tool (P/N 593-902) supplied with vendor.
4. Line up the hub tool "V" cutout (horizontally for 4 & 5 shelves, vertically for 8 & 10 shelves) to the motor shaft gap.
5. Push the hub tool in while pulling on the helix hub outward. Helix should snap off.

6. Disconnect the motor harness connection.
7. Press down on the top locking tab and push the motor out.
8. To install the motor and hub reverse this procedure.

NOTE:

Hub Tool not needed to reinstall hub. When reattaching the helix to the hub, push until it snaps on.

9. Turn the main power ON.

Universal Shelf Conversion

1. Converting from a Dual Helix to a Single Helix selection.
 - a. Remove the left and right helixes.
 - b. Remove the right side helix hub using the Hub Removal Tool (P/N 593-902).
 - c. Remove the left side gear hub by unscrewing the black rivet plate on the idler box.
 - d. Remove the idler box from the shelf weld assembly. Press down on the top locking tab and push outward.
 - e. Remove the motor assembly by pressing down on the top locking tab and pushing outward.
 - f. Rotate the motor 90° counterclockwise.
 - g. Reinstall the motor assembly to the lower opening by snapping it in place.
 - h. Install the helix hub by positioning the hub slot opening to the right and pushing in until it snaps on.
 - i. Install the main larger helix spiral to the helix hub.
 - j. Reposition the product adjustable wall as desired.
2. Converting from a single to a dual helix.
 - a. Remove the helix.
 - b. Remove the helix hub by using the hub removal tool (P/N 593-902) supplied in vendor.
 - c. Remove the product adjustable wall for extra space.
 - d. Remove the motor assembly from the shelf weld assembly by pressing down on the top locking tab and pushing motor assembly outward.

- e. Rotate the motor 90° clockwise.
- f. Reinstall the motor assembly to the right most slot opening.
- g. Reinstall the helix hub by positioning the hub slot opening to the right and pushing until it snaps on.
- h. Install the idler box to the left most slot opening.
- i. Install the gear hub using the black rivet plate. Position the gear hub with its slot opening to the left side.
- j. Install the larger size helix to the right side hub and install the smaller size helix to the left side gear hub.
- k. Reposition the Product Adjustment Wall as desired.

Section 6

Parts Catalog

INTRODUCTION

This parts catalog contains a list of replacement parts for the vendor that are available from Rowe Distributors. Each list contains an index of the part, Rowe Part Number, a description of the part and the quantity required for the assembly. Separate parts of riveted or welded assemblies are not available from the factory as replacement parts.

Parts Callout

Each table in the Parts Callout contains four columns. Following is a description of each column in the order of appearance on the Parts Callout tables.

Figure and Index No.

This column lists the figure number as the first entry on each page. An index number keys the part to the figure.

ROWE Part Number

This column lists the part number of the item that should be used for ordering. The same part, whenever used, retains the same number.

Description

This column gives the name of the assembly or part.

Quantity Per Assembly

This column contains the exact quantity of the item required for this assembly.

ORDERING REPLACEMENT PARTS

All parts must be ordered from an authorized Rowe Distributor. Parts orders are often delayed because of inadequate or incomplete ordering information. To avoid such delays, make sure to include all necessary information as indicated below.

1. Rowe Part Number and Description exactly as it appears in the Parts Catalog. State color if applicable.
2. Quantity being ordered.
3. Model and Serial Number of vendor for which the part is required. This is necessary because of manufacturing changes and updates.
4. Complete shipping address.
5. Specify shipping instructions. It is advisable to indicate an alternate shipping method if the packages may exceed the size and weight limits established by the shipping agency of your choice.

Note the voltage of electrical components.

OPTIONAL KITS

5900S Part No.	5900JR Part No.	5900C Part No.	DESCRIPTION	FUNCTION
425-6037	"	"	UBA Bill Acceptor kit	Allows currency acceptance
490-1925	"	"	Product Pusher Kit	Pushes product out
490-4501	"	"	Shelf Extender Cable Assembly	Service shelf outside of cabinet
490-6007	"	"	Product Filler Kit	Vends pastry
493-6037	494-6024	N/A	Display Retainer Kit	Added security (Lexan)
494-6000	"	"	Door Lock Kit	Improve locking
593-6001	494-6011	591-6000	Kick Plate Kit	Styling
593-6004	"	"	Fan Kit	Provides circulation
593-6005	"	"	Honor Guard Mounting Kit	Replaces cash box w/ locked
593-6006	"	"	Additional Honor Guard	Removable cash bag
593-6007	"	"	Gum and Mint Adapter Kit (Tums)	Vends "Tums & Certs"
593-6008	"	"	Mars VFM3 B/A Kit	Mars B/A usage
593-6011	"	"	Debitek Components Kit	Debitek card reader usage
593-6012	"	"	Handicapped Selector Keypad Kit	Lowers keypad
593-6015	"	"	Can Vendor Kit (12 Ounce)	Vends canned foods
595-6000	"	"	Air Intake Screen Kit (Refrig. Units Only)	Easy removable screen

SERVICE PARTS ONLY

490-28	"	"	Helix, 30 Count - Candy	
490-29	"	"	Helix, 24 Count - Candy	Fits Product <3/4"
490-30	"	"	Helix, 18 Count - Candy	Fits Product <1 1/16"
490-31	"	"	Helix, 15 Count - Candy	Fits Product <1 5/16"
490-32	"	"	Helix, 15 Count - Pastry	Fits Product <1 5/16"
490-33	"	"	Helix, 12 Count- Pastry	Fits Product <1 11/16"
490-34	"	"	Helix, 10 Count - Pastry	Fits Product <2 1/16"
490-4013	"	"	Helix, 7 Count (Can) (12 Ounce)	Fits Can Products
493-15	"	"	Helix, 12 Count - Candy	Fits Product <1 5/8"
493-16	"	"	Helix, 10 Count - Candy	Fits Product <2"
593-11	"	"	Reverse Helix 15 Count - Candy	Fits Product <1 5/16"
593-12	"	"	Reverse Helix, 12 Count - Candy	Fits Product <1 5/8"
593-13	"	"	Reverse Helix, 10 Count - Candy	Fits Product <2"
593-14	"	"	Helix, 6 Count	Fits Lunch Bucket
593-15	"	"	Helix - Dual, Reverse Prod. L/H	(30 Ct.)

PARTS CATALOG

Table of Contents

FIG. NO.	TITLE	PAGE
1	Main Door Trim and Panels	6 - 4
2	Main Door Exterior	6 - 6
3	Main Door Interior	6 - 8
4	Delivery Box Assembly	6 - 10
5	Cabinet Assembly Components	6 - 12
6	Power Panel Components	6 - 14
7	Selection Panel	6 - 16
8	Shelf Support and Plug Assemblies	6 - 17
9	Sliding Panel Components	6 - 18
10	3/4/5 Selection Shelf	6 - 20
11	Dual Helix Shelf	6 - 22
12	Candy Shelf	6 - 24
13	Gum & Mint Unit Final Assembly	6 - 26
14	Refrigeration Unit	6 - 28
15	Main Controller Circuit Board Asm	6 - 30
16	Display Board	6 - 32
17	Harness List	6 - 33

Main Door Trim and Panels

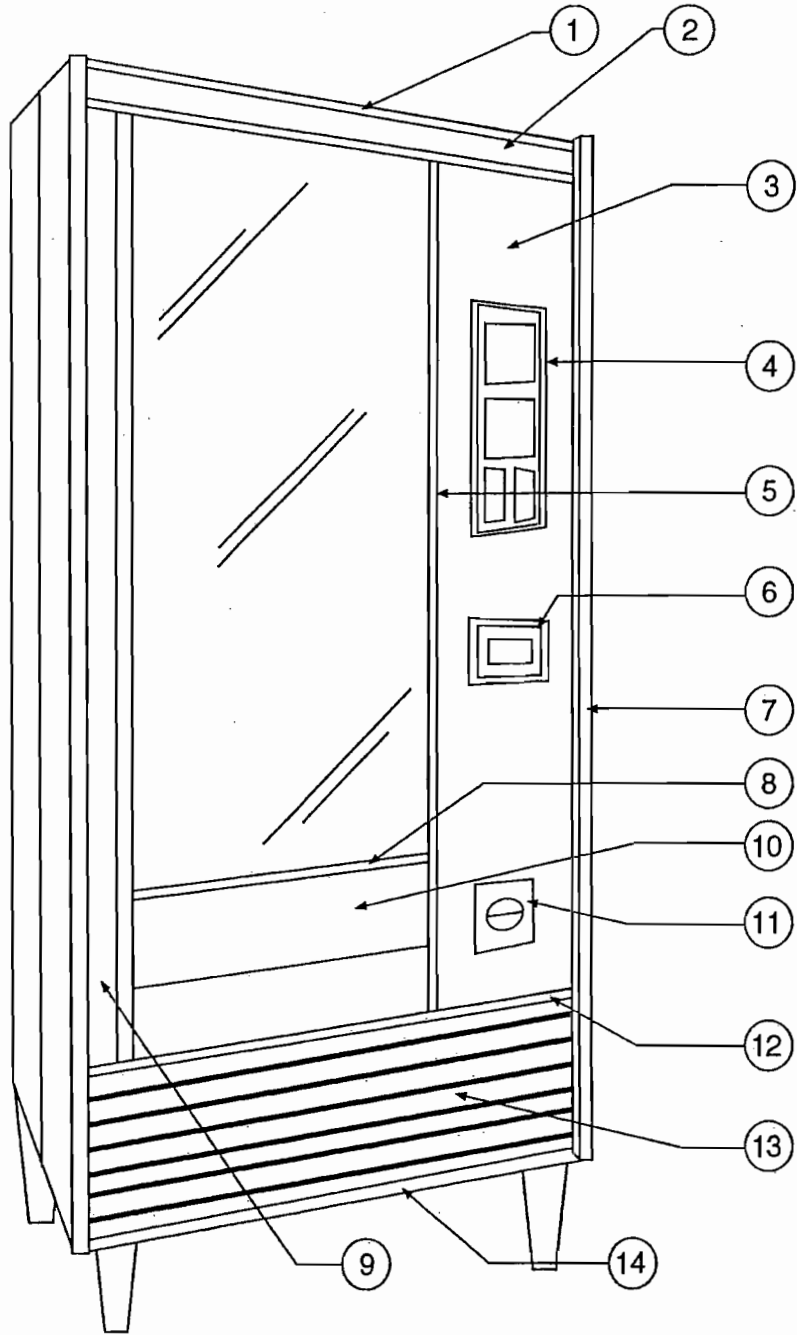

Main Door Trim and Panels

MODEL & STYLE		5900S GENESIS	5900JR GENESIS	5900C GENESIS
1	Header Channel	983-5	983-7	983-3
2	Header Insert	985-4-9	985-5-9	985-20-9
3	Overlay R/H Vertical w/BA	593-426-9	593-426-9	593-426-9
	Overlay R/H Vertical wo/BA	493-20508-9	493-20508-9	493-20508-9
4	Instruction Overlay w/Bill Acceptor	593-408	593-408	593-408
5	Trim - R/H & L/H Display Window	983-478	983-478	983-478
6	Overlay Bill Acceptor (Universal)	593-412	593-412	593-412
7	Trim - L/H & R/H Vertical	983-101	983-101	983-101
	Trim Retainer	983-325	983-325	983-325
8	Trim - Bottom Display	983-479	983-480	983-481
9	Overlay L/H Vertical	985-32-9	985-32-9	983-32-9
10	Overlay Center	490-485-78	494-432-78	591-411-78
11	Overlay Coin Return Cup	408-506	408-506	408-506
12	Trim Bottom Display	983-225	983-226	983-234
13	Overlay Lower Door	985-23-9	985-24-9	591-1407-9
14	Trim Bottom	493-484-309	494-442-309	591-412-309

There are many combinations of panel and overlay finishes based on individual company preferences. Part numbers for the styling overlays and panels are generally the same with the exception of the last dash number, which denotes the finish of the part. For example, item No. 2 above is 985-4-9 (Header Insert - Black). If this part were desired in a Presidential Walnut finish, the part number would be 985-4-2. The chart below lists the dash numbers and the corresponding finish.

HORIZONTAL PANELS		VERTICAL PANELS	
- 1 Roweswood	-15 Stainless Steel Mylar	- 2 Presidential Walnut	
- 2 Presidential Walnut	-29 Teak	- 7 Shadow Silver	
- 3 Regency Walnut	-32 Terra Cotta	-11 Brushed Bronze	
- 9 Black	-69 Chamois	-12 Port-Au-Prince	
-10 Golden Leather		-13 Stainless Steel Mylar	
		-29 Teak	
		-79 Charcoal Brown	

Main Door Exterior

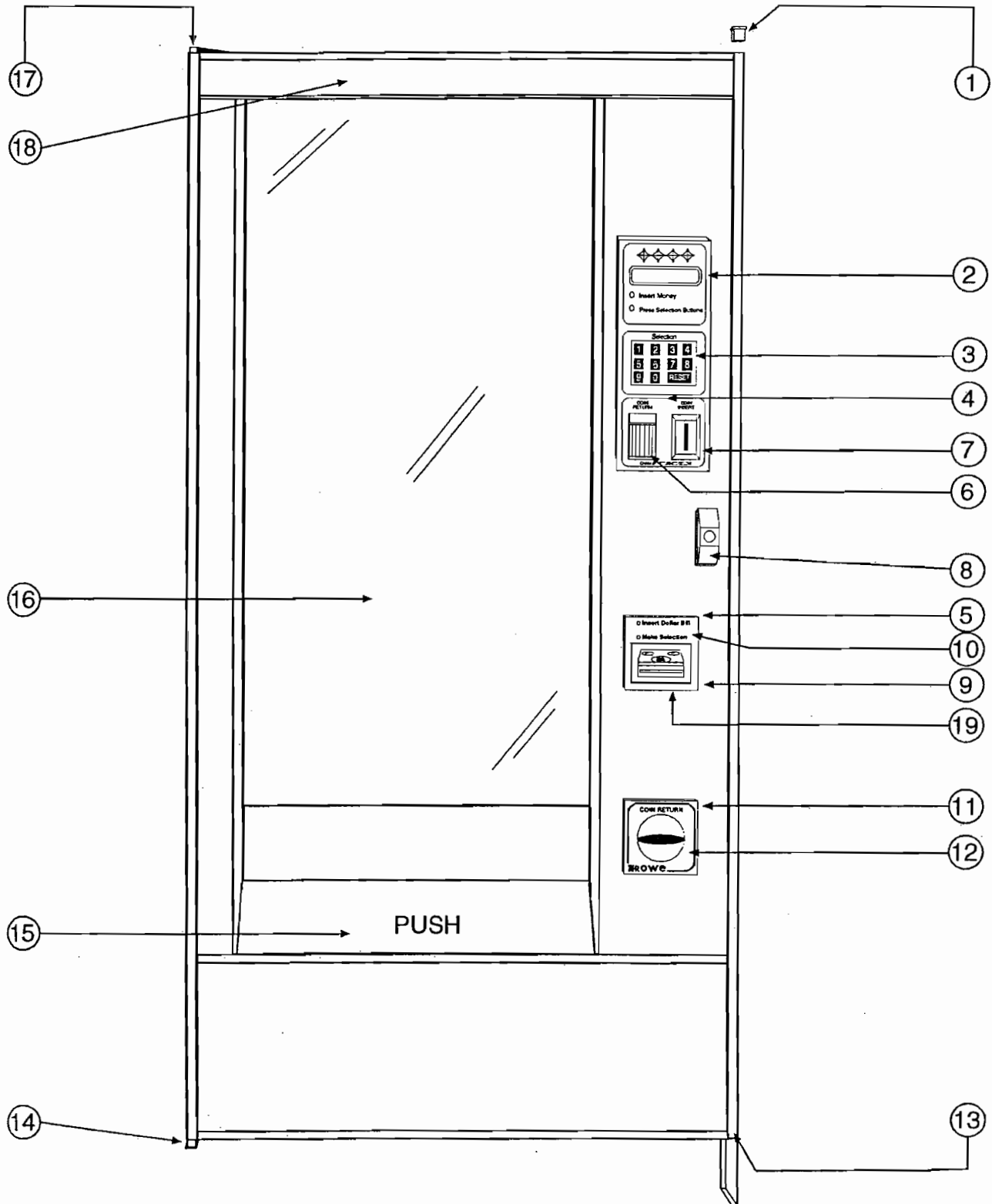

Main Door Exterior

Index No.	5900S Part Number	5900JR Part Number	5900C Part Number	Description	Quantity Per Assembly
	593-1420	594-1420	591-1400	Main Door Final Asm.	REF
	593-1421	594-1421	591-1401	Main Door W/A	REF
1	408-511	Same	Same	Cap, Trim Top	1
2	593-405	"	"	Bezel, Coin Insert and Instruction	1
	924-176	"	"	Nut, Bezel Anchoring	4
3	490-824	"	"	Bezel, Selection Switch (See Figure 7)	1
	924-176	"	"	Nut, Bezel Anchoring	6
4	593-408	"	"	Overlay, Coin Insert	1
5	493-1473	"	"	Overlay - Black Service cover plate (Universal)	1
	493-1474	"	"	Overlay - Brown Service cover plate (Universal)	1
6	490-470	"	"	Slide, Coin Return	1
7	490-584	"	"	Gate, Coin Insert	1
8	479-1420	"	"	Handle, Pop-Out	1
9	408-495	"	"	Bezel, Bill Acceptor	1
10	593-412	"	"	Overlay B/A (Black)	1
	593-413	"	"	Overlay B/A (Brown)	1
	924-176	"	"	Nut, Bezel Anchoring	2
	493-1475	"	"	B/A Mounting Plate (Universal)	1
	493-1471	"	"	Label Assembly, Filler Plate (Universal)	1
	425-443	"	"	Backing Plate	1
	907-2039	"	"	Label, "Insert Bill Face Up"	1
11	490-408	"	"	Bezel, Coin Return Cup	1
	924-176	"	"	Nut, Bezel Anchoring	4
12	408-506	"	"	Overlay, Coin Return (Black)	1
	408-505	"	"	Overlay, Coin Return (Brown)	1
13	408-510	"	"	Cap, Trim Bottom	1
14	448-1407	"	"	Pivot Plate R/A, Bottom	1
15	593-1405	594-1405	591-1402	Delivery Box Asm. (See Figure 4)	1
16	493-408	494-428	591-414	Glass, Display	1
	490-474	494-413	591-416	Mounting Bracket, Display Glass - Upper (Behind Trim)	1
17	448-1309	Same	Same	Pivot Plate Rivet Asm. Top	1
	921-52	"	"	Machine Screw	2
	950-102	"	"	Washer	2
	903-20	"	"	Carriage Bolt	1
	924-160	"	"	Nut	1
	934-413	"	"	Self Tapping Screw	2
	921-496	"	"	Screw, Plate Anchoring	3
18	493-410	"	"	Filler Plate and Glass Retainer (Not Shown)	1
19	493-1929	"	"	B/A Block Out Plate (Not Shown)	1

Glass Sizes:

493-408 26 ⁵/₈ x 42 ³/₈ x ¹/₈ Thick Tempered Tuff

494-428 21 ¹/₄ x 42 ³/₈ x ¹/₈ Thick Tempered Tuff

591-414 15 ⁷/₈ x 42 ³/₈ x ¹/₈ Thick Tempered Tuff

Main Door Interior

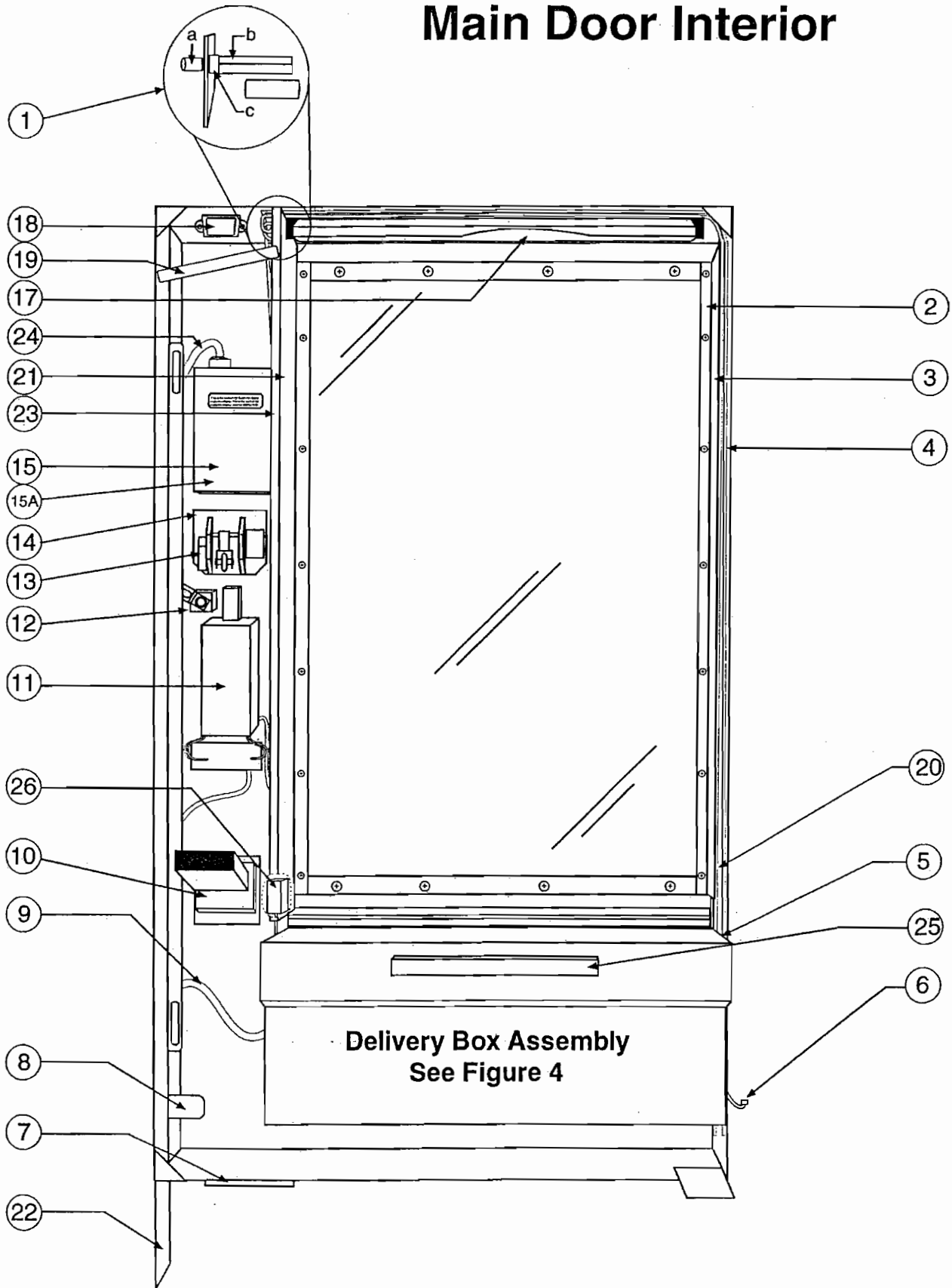

Main Door Interior

Index No.	5900S Part Number	5900JR Part Number	5900C Part Number	Description	Quantity Per Assembly
	593-1420	594-1420	5911-1400	Main Door Final Assembly	REF
	593-1421	594-1421	591-1401	Main Door Weld Assembly	REF
1	493-1810	494-1802	591-1800	Bracket, Lamp Assembly	1
a	141-828	794-461	794-461	Starter, Fluorescent Lamp	1
b	493-412	494-411	591-800	Bracket, Lamp Mounting	1
c	976-21	Same	Same	Starter and Socket Assembly	1
2	493-411	"	"	Bracket, Display Glass Mounting - L/H & R/H Sides	2
	934-285	"	"	Screw	9
3	493-413	"	"	Shroud Delivery Box L/H Side	1
	934-286	"	"	Screw	12
4	493-1885	"	"	Harness Assembly, Display Light	1
	979-104	"	"	Plug	1
	979-1102	"	"	Socket - 2 Pin	1
	975-596	"	"	Harness Clamp	1
5	493-434	"	"	Spring, Delivery Box Link	2
6	593-1828	"	"	Harness, Dispenser to Power Panel	1
7	448-739	"	"	Plate, Door Ramp	1
	934-380	"	"	Screw, Plate Mounting	2
8	485-407	"	"	Plate, Interlock Switch Actuating	1
	934-485	"	"	Screw, Plate Mounting	2
9	593-1830	"	"	Harness, Bill Acceptor	1
10	493-1465	"	"	Cup Assembly, Coin Return	1
	490-409	"	"	Flap, Coin Return Cup	1
	490-424	"	"	Pivot Shaft, Coin Return Flap	1
	493-1466	"	"	Coin Return Cup W/A	1
	924-176	"	"	Nut	14
11	425-6037	"	"	Bill Acceptor (See Service Man 25520901)	OPT
12	494-419	"	"	Cam, Door Lock	1
	924-181	"	"	Nut	1
	490-353	"	"	Stop Spring	1
	493-1462	"	"	Pin and Locking Bar	1
	933-109	"	"	Retainer - Push Nut	1
13	490-584	"	"	Gate Coin Insert	1
14	493-1463	"	"	Coin Insert and Return Assembly	1
	490-435	"	"	Pivot Shaft	2
	490-498	"	"	Spring, Coin Return	1
	490-1406	"	"	Coin Chute and Bracket W/A	1
	490-5	"	"	Plastic Roller	1
15	593-1827	"	"	Display and P.C. Board Asm. (Not Shown)	1
	593-804	"	"	Cover, Display and Display Boards	1
	939-1302	"	"	Insulator, Fishpaper (Not Shown)	1
15A	490-595	"	"	Bracket, Cover Mounting	1
16	490-474	494-413	591-416	Upper Glass Mounting Bracket	1
17	917-103	794-462	917-115	Lamp Fluorescent	1
18	490-1885	Same	Same	Ballast Assembly	1
19	494-437	"	"	Brace, Door Shroud	1
20	928-1531	"	"	Gasket - Edge cable protector	1
21	593-423	"	"	Shroud Delivery Box R/H Side	1
22	448-575	"	"	Leg, Door	1
	934-428	"	"	Screw	3
23	908-5049	"	"	Label, Service Flow Chart (Not Shown)	1
24	593-1828	"	"	Harness - Display to Power Panel	1
25	928-1433	"	"	Gasket - Type 55 (8 1/2")	1
26	593-1422	"	"	Damper Box Assembly	1
	934-431	"	"	Screw	2
	593-439	"	"	Spring	1
	933-5	"	"	Circle Clip	1

Delivery Box Assembly

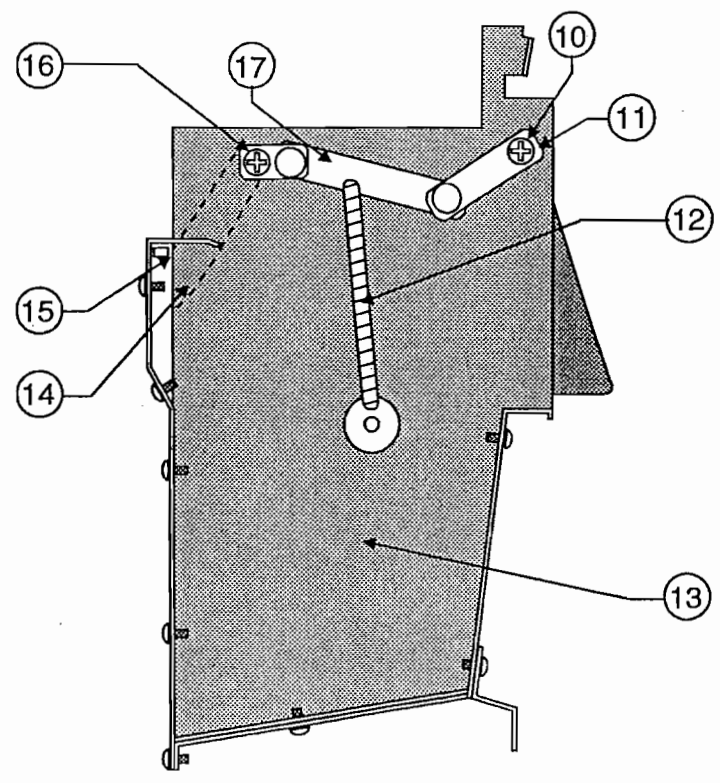
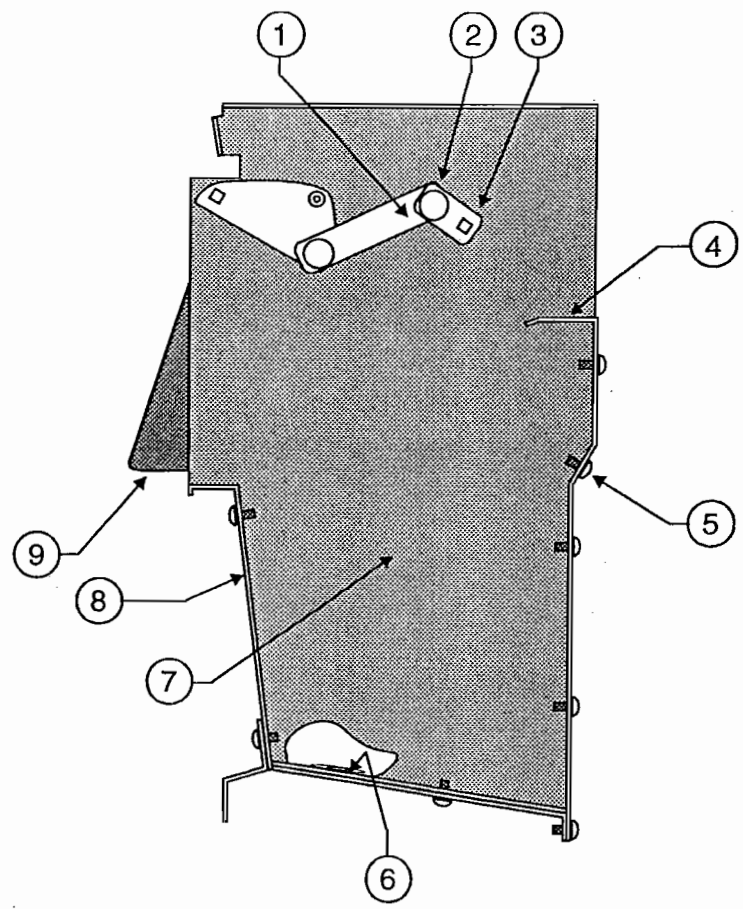

Delivery Box Assembly

Index No.	5900S Part Number	5900JR Part Number	5900C Part Number	Description	Quantity Per Assembly
	593-1405	594-1405	591-1402	Delivery Box Assembly	1
1	593-1412	Same	Same	Delivery Box Linkage Rivet Assembly, R/H*	1
2	493-456	"	"	Spacer (Not Shown)	4
3	916-88	"	"	Grommet (Not Shown)	4
4	593-417	594-404	591-406	Rear Cover Weld Assembly	1
5	934-485	Same	Same	Machine Screw	21
6	493-926	"	"	Recessed Plug	2
7	593-1407	"	"	Delivery Box Frame R/A Right	1
8	493-1433	494-1407	591-1404	Front Cover W/A	1
9	493-1434	494-1405	591-1403	Front Door R/A	1
10	921-310	"	"	Machine Screw 8-32 x ⁵ / ₁₆	2
11	950-344	"	"	Lock Washer (Not Shown)	2
12	490-353	"	"	Spring Door Stop	1
13	593-1406	"	"	Delivery Box Frame R/A Left	1
14	593-1408	594-1408	591-1406	Rear Door R/A	1
15	593-420	594-402	591-413	Baffle Rear	1
16	921-299	Same	Same	Machine Screw 8-32 X ⁵ / ₁₆	1
17	493-1436	Same		Linkage Rivet Assembly, L/H	1

* Machines equipped with an air damper assembly.

** Machines not equipped with an air damper assembly.

Cabinet Assembly Components

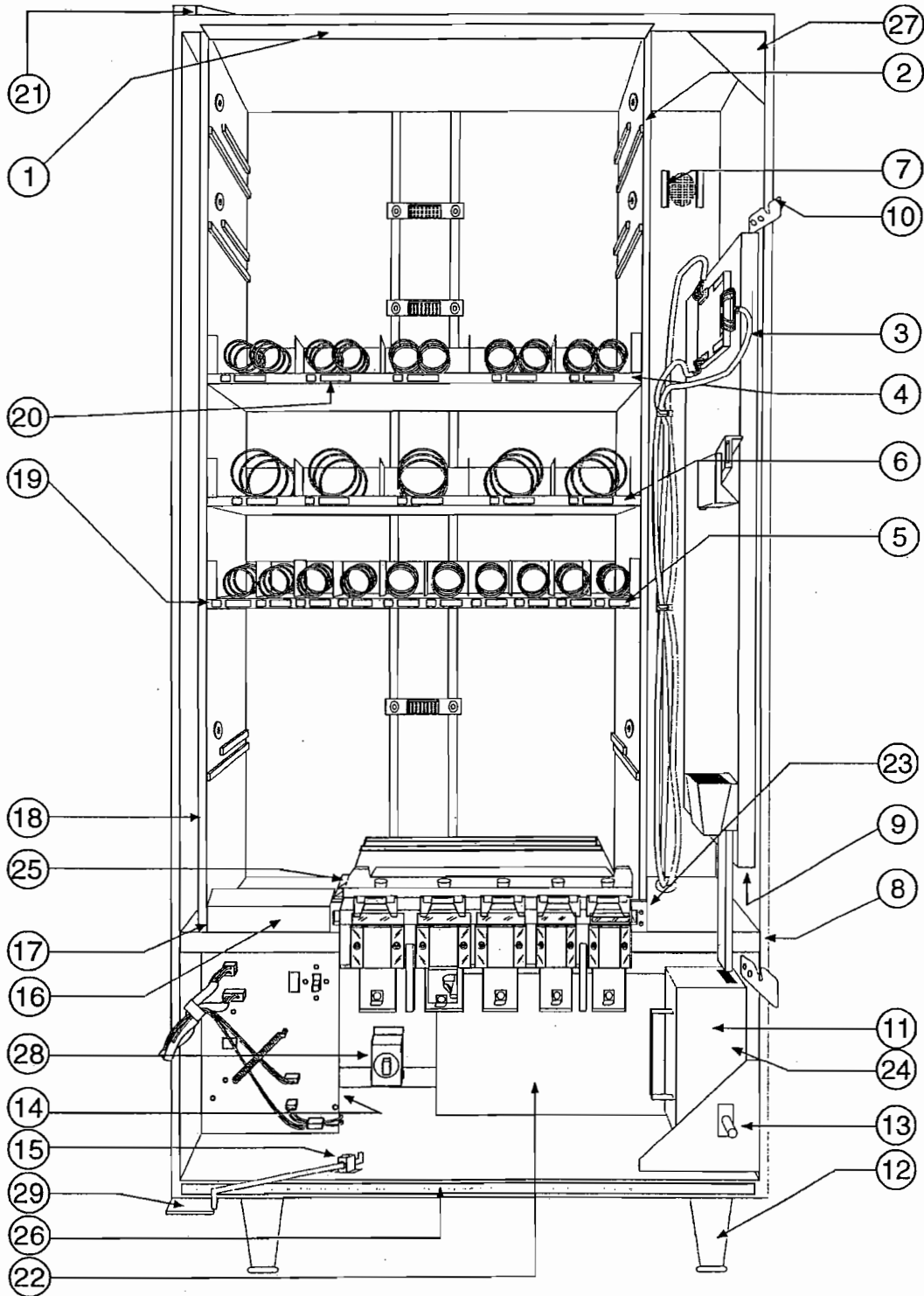

Cabinet Assembly Components

Index No.	5900S Part Number	5900JR Part Number	5900C Part Number	Description	Quantity Per Assembly
	593-1910	594-1910	591-1900	Cabinet Assembly	REF
	593-1315	594-1315	591-1301	Cabinet W/A	1
1	493-911	494-901	591-902	Shield, Light and Security	1
	934-284	Same	Same	Screw, Shield Anchoring	3
2	593-914	"	"	Panel W/A, Shelf Mounting R/H Side	1
3	593-1911	"	"	Sliding Panel Asm. See Fig. 9	1
	490-906	"	"	Slide Rail, Jonathan (Hidden)	1
4	593-1600	594-1600	591-1600	Shelf Asm., Dual Helix - See Fig. 12	REF
5	593-1610	594-1610	591-1606	Shelf Asm., 10/8/6 Selection - See Fig. 11	REF
6	593-1605	594-1605	591-1603	Shelf Asm., 5/4/3 Selection - See Fig. 11	REF
7	493-955	Same	Same	Track Blower Flange	1
8	866-68001	"	"	Rubber Channel	A/R
9	593-907	"	"	Guide, Sliding Panel Interface	1
	934-307	"	"	Screw, Guide Mounting	1
10	493-325	"	"	Hook, Door Locking	2
	934-394	"	"	Screw, Lock Hook Mounting	4
11	593-1904	"	"	Coin Box W/A	1
	593-906	"	"	Bracket, Coin Box Retaining	1
	593-905	"	"	Spring, Coin Box Retaining	1
12	408-1316	"	"	Leg W/A, Cabinet (Includes Leveler)	4
	408-352	"	"	Leg Leveler	4
	490-395	"	"	Channel, Leg Mounting (Not Shown)	2
13	447-1869	"	"	Switch, Main Door Interlock	1
14	593-1820	"	"	Transformer Box Asm. - See Figs. 8	1
15	595-912	"	"	Mounting Bracket, Friction Pad	1
	490-389	"	"	Pad, Friction	2
	490-391	"	"	Washer, Curved	2
	934-394	"	"	Screw, Self Tapping	4
	595-911	"	"	Stop Rod, Main Door	1
16	593-745	594-745	591-709	Baffle	1
	934-174	Same	Same	Screw	2
17	493-323	"	"	Baffle, Delivery Box	1
	493-324	"	"	Bracket, Baffle Mounting	1
	934-485	"	"	Screw, Baffle Mounting	4
18	593-913	"	"	Panel W/A, Shelf Mounting - L/H Side	1
	595-913	"	"	Panel W/A, Shelf Mounting - L/H Side (W/ Refrig.)	1
19	593-1908	"	"	Selection Indicator Assortment	1
20	593-1913	"	"	Selection Price Card Assortment	1
21	448-1309	"	"	Top Pivot Plate Assembly	1
22	595-1205	"	NA	Refrigeration Unit (Domestic) (See page 3 - 32)	OPT
	595-21505	"	NA	Refrigeration Unit(Euro.) (See page 3 - 32)	OPT
23	593-742	"	"	Support - Front (Nylon)	2
	934-172	"	"	Screw #8 x 5/8"	4
	593-746	594-746	591-710	Baffle G&M Removal (Not Shown)	OPT
24	493-4502	Same	Same	Locking Cash Box	OPT
25	593-1712	"	"	Bracket & Gusset W/A	1
26	866-55001	"	"	Gasket - Rubber, Sponge 1/4" X 1/2"	1
27	593-322	"	"	Gusset - Cabinet	1
28	595-21507	"	NA	Thermostat and Bracket Assembly	1
	595-21514	"	NA	Thermostat	1
	595-20501	"	NA	Cover - Temperature Control	1
	921-35	"	NA	Screw - Machine 8-32 x 1/4"	2
29	448-1306	"	"	Pivot Bracket W/A	1

Power Panel Components

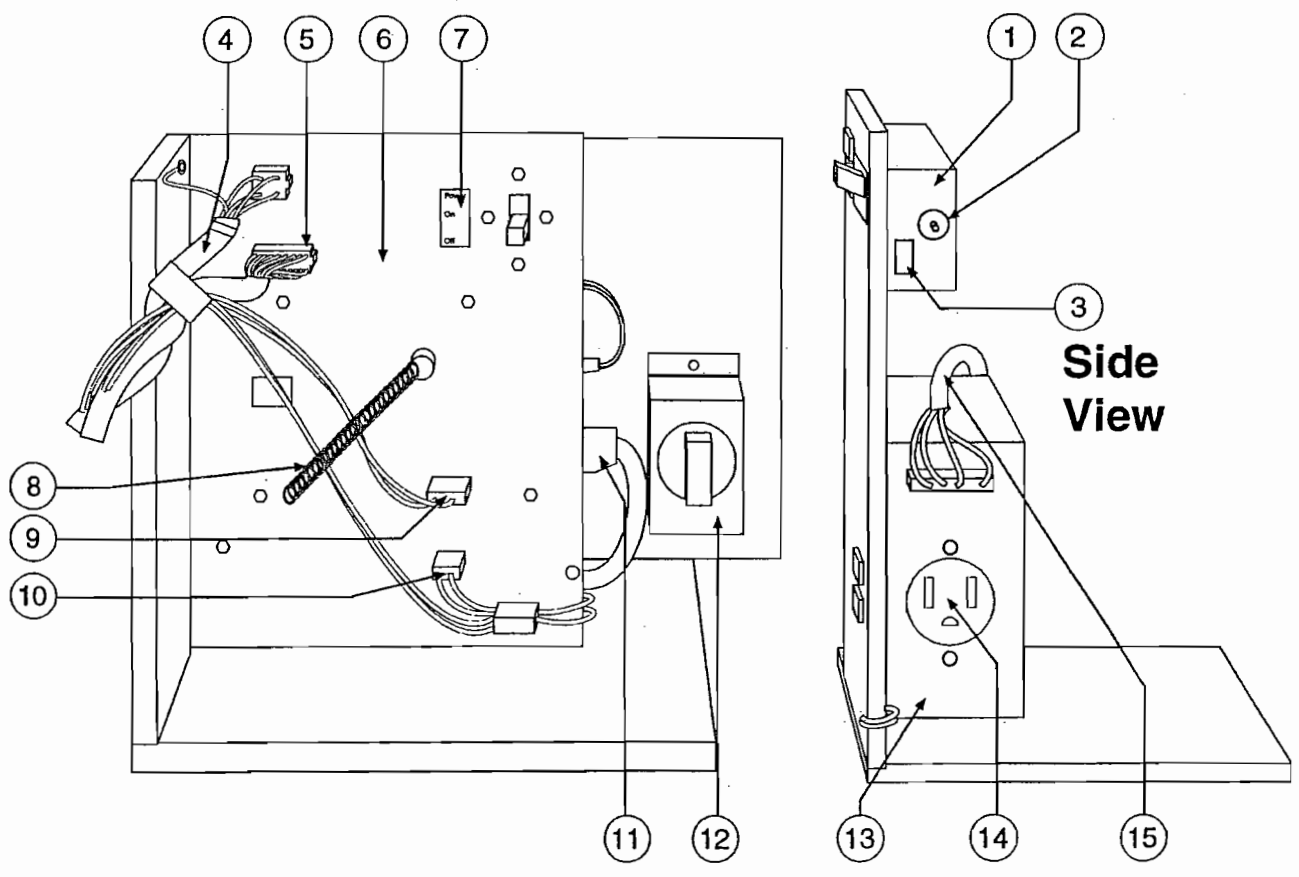

Power Panel Components

Index Number	Rowe Part Number	Description	Quantity Per Assembly
1	493-1861	Power Switch Assembly	1
	301-1711	Toggle Switch	1
	493-808	Chassis - Front	1
	493-809	Chassis - Rear	1
	934-307	Screw - Chasis	4
	921-207	Screw - Power Switch Mtg.	2
	493-1856	Power Cord Assembly	1
2	912-52	Fuse - 12 Amp. Circuit Breaker (Included w/ 493-1861)	1
3	907-2226	Label "12 Amp. Circuit Breaker" (Included w/ 493-1861)	1
4	593-1813	Harness - B/A Data Line	1
	972-1072	Connector Socket - Power Panel	1
	979-1219	Socket - B/A End	1
5	593-1829	Harness - Power Panel to P6	1
	979-1079	Socket - Power Panel	1
	979-1277	Socket - P6 End	1
6	593-315	Power Panel	1
7	907-2083	Label - "Power ON - OFF"	1
8	212-328	Spring	1
	934-175	Screw 6-32 x 3/16"	1
9	493-1885	Harness - Light Assembly	1
	979-102	Plug	1
	979-104	Plug	1
	979-1102	Socket	2
10	593-1832	Harness - Fan	1
	979-194	Plug - Power Supply End	1
	979-1105	Socket - Fan End	1
11	595-1800	Refrigeration Line Cord (Domestic)	1
	595-21512	Refrigeration Line Cord (European)	1
12	595-21507	Thermostat and Bracket Assembly	1
	595-20501	Cover - Temperature Control	1
	595-21514	Thermostat	1
	921-35	Screw - Machine 8-32 x 1/4"	2
13	593-1820	Transformer Box Assembly	1
	593-1821	Transformer - Terminated	1
	593-800	Transformer Box	1
	593-801	Transformer Box Cover	1
	934-307	Screw - Power Supply Mounting	1
	419-1860	Transformer Assembly - 220/240 European - (Not Shown)	A/R
14	979-1275	Socket	1
15	593-1807	Harness - Power Supply to P1	1
	979-196	Plug	1
	979-1192	Socket	1

Selection Panel Components

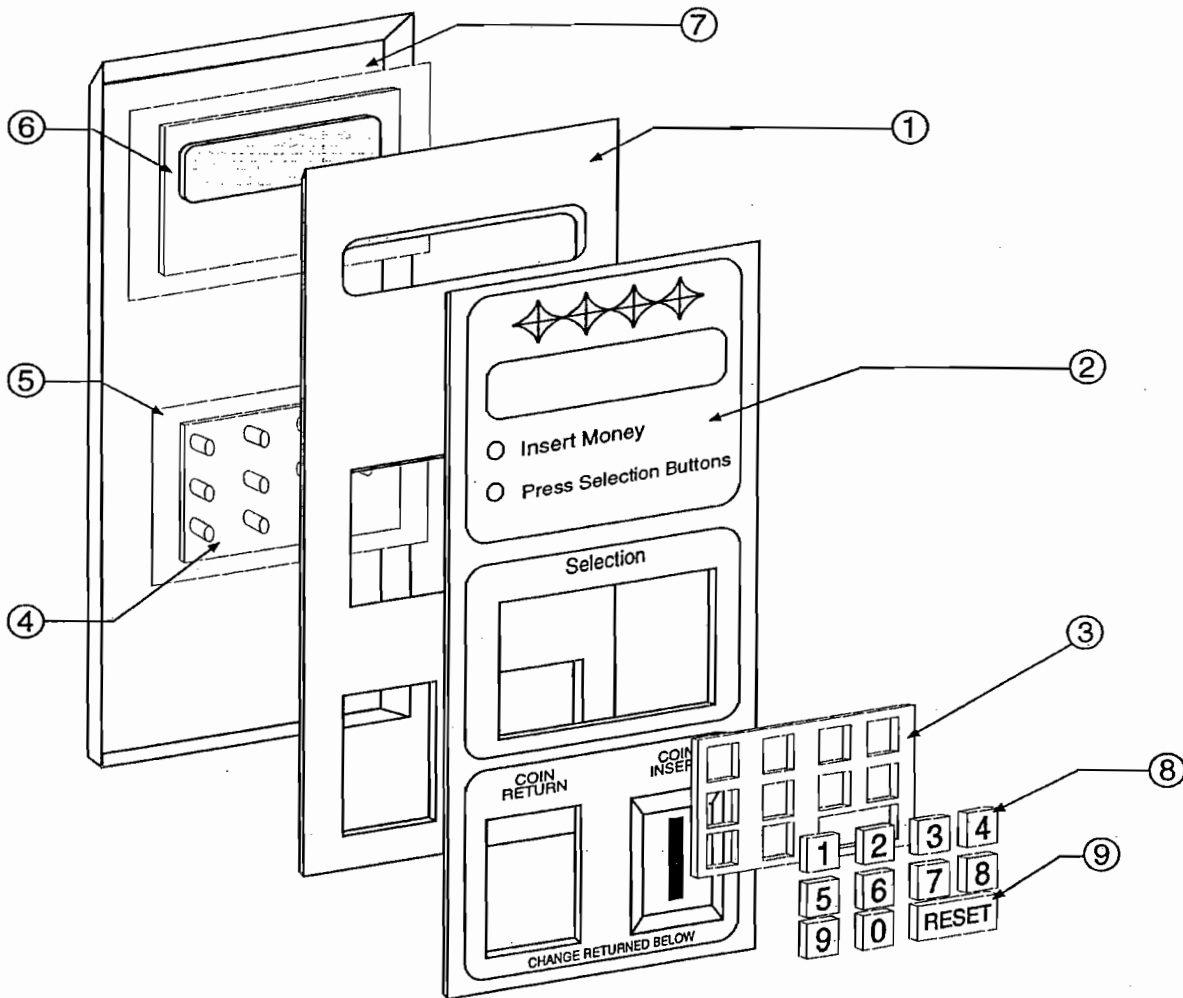

Index Number	Rowe Part Number	Description	Quantity Per Assembly
1	593-405	Bezel - Coin Insert and Instruction	1
2	593-408	Overlay - Coin Insert	1
3	490-824	Bezel, Selection switch (plastic grid between buttons)	1
4	010-40764-301	Pushbutton Switch Asm.	1
5	010-40764-401	Printed Wiring Board (Not available separately)	1
6	593-1827	Display Board Assembly	1
7	593-804	Cover - Display and P.C. Board	1
8	010-30838-126	Pushbutton Set (1-0)	1
9	010-30743-203	Reset Button	1

Shelf Support and Plug Assemblies

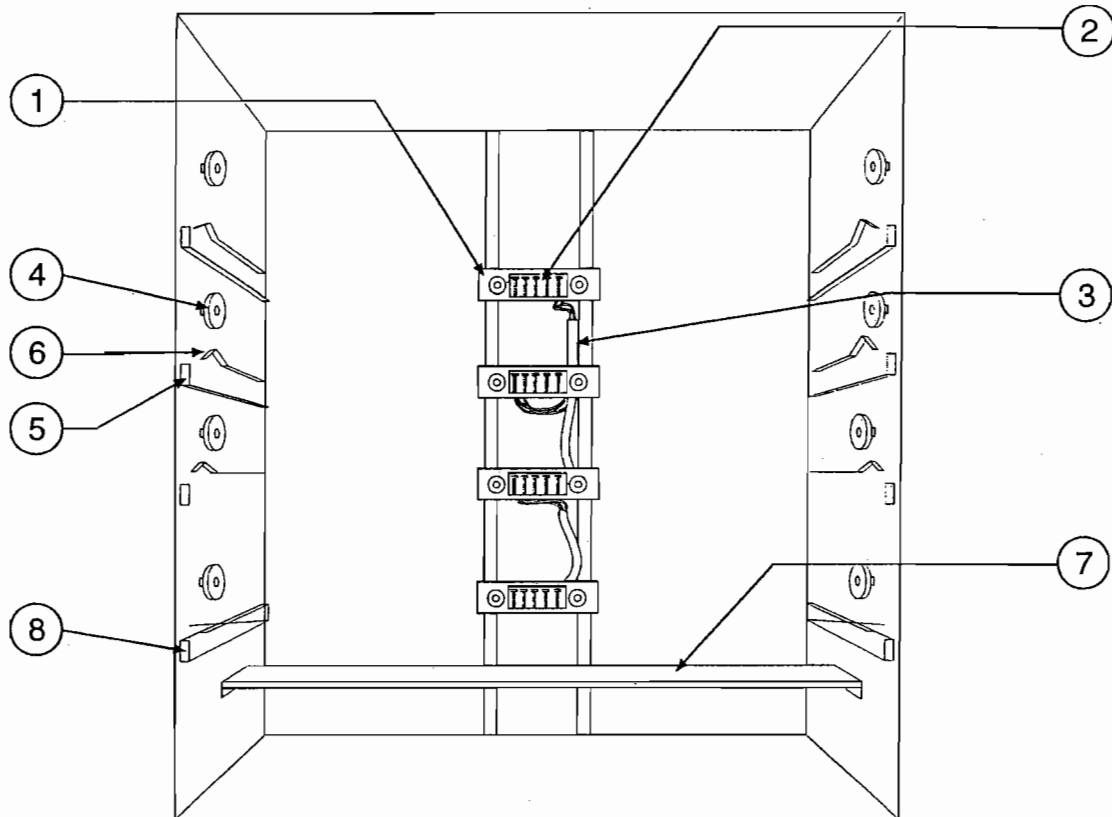

Index No.	5900S Part Number	5900JR Part Number	5900C Part Number	Description	Quantity Per Assembly
1	593-1824	Same	Same	Plug Bracket W/A	6
	593-805	"	"	Plug Bracket	1
	490-352	"	"	Step Washer	2
2	979-1253	"	"	Socket, 15 Pin Female	6
	593-1839	"	"	Harness Asm., Main Cabinet (Behind Cover)	1
3	979-1211	"	"	Socket - 19 Pin	1
	979-1253	"	"	Socket - 15 Pin	7
	979-1221	"	"	Socket - 16 Pin	1
	490-5	"	"	Roller, Shelf	12
4	490-6	"	"	Bushing, Shelf Roller	12
	934-484	"	"	Screw, Self Tapping	10
	493-1308	"	"	Lower Shelf Support W/A - L/H Side	4
5	493-1309	"	"	Lower Shelf Support W/A - R/H Side	4
	493-1321	"	"	Upper Shelf Support W/A - L/H Side	4
6	493-1322	"	"	Upper Shelf Support W/A - R/H Side	4
	593-314	594-314	591-314	Tie Bar L/H & R/H Partition	1
7	934-307	Same	Same	Screw, Self Tapping	4
	493-1308	"	"	Shelf Support L/H	3
8	493-1309	"	"	Shelf Support R/H	3
	934-151	"	"	Screw - Self Tapping	18

Sliding Panel Components

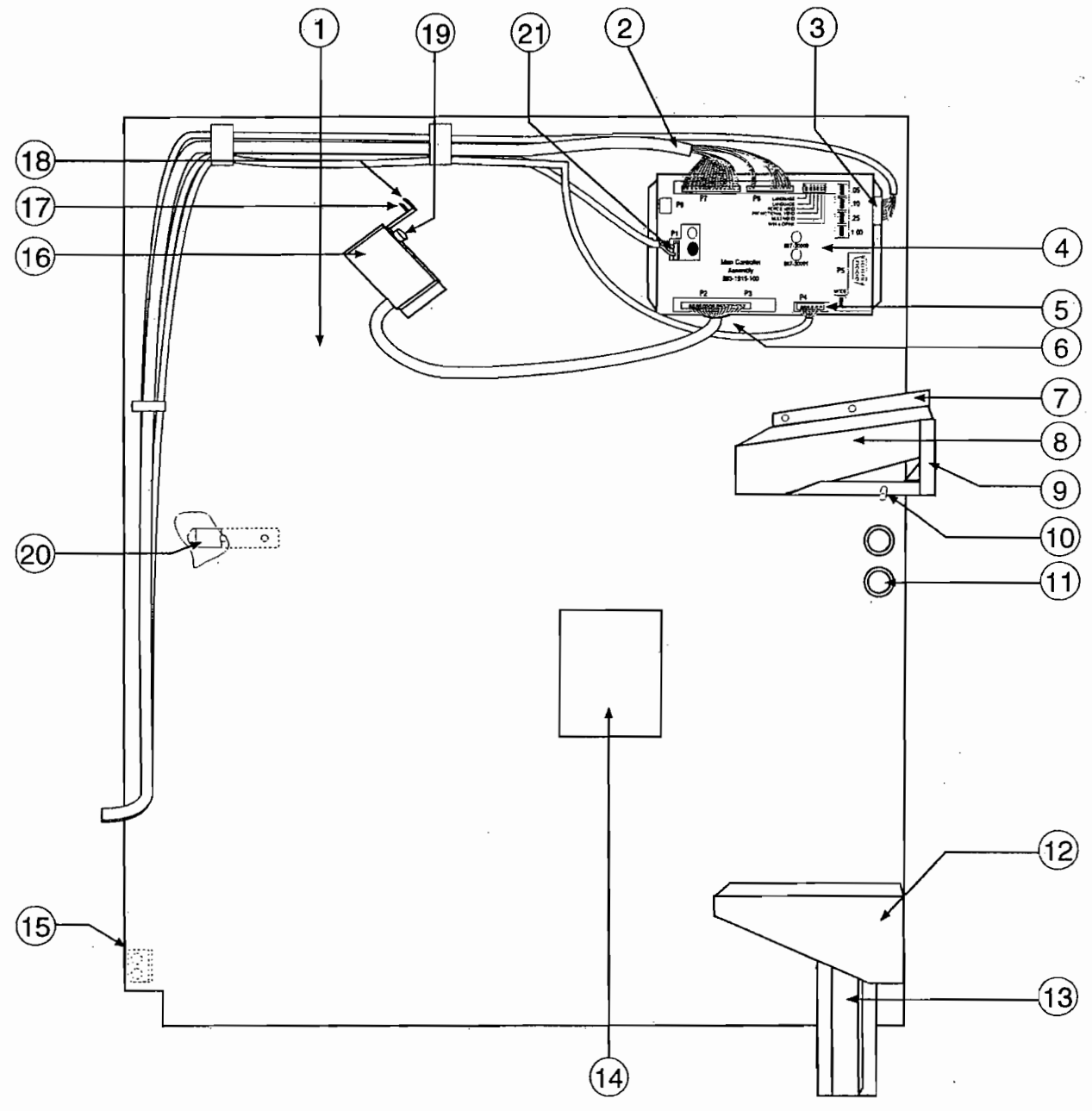

Sliding Panel Components

Index Number	Rowe Part Number	Description	Quantity Per Assembly
	593-1911	Sliding Panel Assembly	REF
1	494-1927	Sliding Panel Weld Assembly	1
2	593-1839	Harness - Cabinet (5&6 Shelf)	1
	593-1840	Harness - Cabinet (7 Shelf Not Shown)	1
3	593-1829	Harness - Power Panel to P6	1
	979-1079	Electric Socket	1
	979-1277	Socket	1
4	593-1845-100	Controller Assembly	1
	934-307	Screws, Self-Tapping	2
5	593-1813	Harness - B/A Data Line	1
	979-1219	Socket - 7	1
	979-1072	Connector	1
6	593-1806	Harness - Coin Mech to P2	1
	593-21012	Harness - Coin Mech to Power Module (European)	1
	593-21013	Optional Coin Mech Harness (European)	1
7	493-915	Chute - Mounting Bracket, Coin Mech	1
	934-151	Screw - Self Tapping	2
8	493-916	Chute - Coin Mech	1
	493-917	Chute - Inner Coin Mech (Not Shown)	1
	934-151	Screw - Self Tapping	2
9	493-1908	Coin Mech Lever Weld Assembly	1
10	593-912	Pivot Pin - Retaining	1
	490-616	Spring	1
	924-62	Nut - 1/4-20 Type 6	1
	933-5	Retaining Ring	1
11	493-926	Plug Recessed	2
12	490-1607	Slug Cup Chute	1
	934-151	Screw - Self Tapping	2
13	593-1912	Coin Chute - Lower Weld Assembly	1
	934-151	Screw - Self Tapping	2
14	907-748	Label - Coin Mech Listing	1
15	494-906	Strip - Angle	1
16	593-1831	Coin Mech Bracket & Harness Assembly	1
	595-21518	Coin Mech Bracket and Harness Assembly (European)	1
	934-307	Screw - Self Tapping	1
17	448-2477	Coin Mech Plug Bracket Holder (Small)	1
18	548-499	Coin Mech Plug Bracket Holder (Large)	1
19	408-431	Knob - Screw	1
20	494-915	Spring - Friction, Sliding Panel	1
	934-151	Screw - Self Tapping	1
21	593-1807	Harness - Power Supply to P1	1

3, 4, or 5 Selection Shelf Assembly

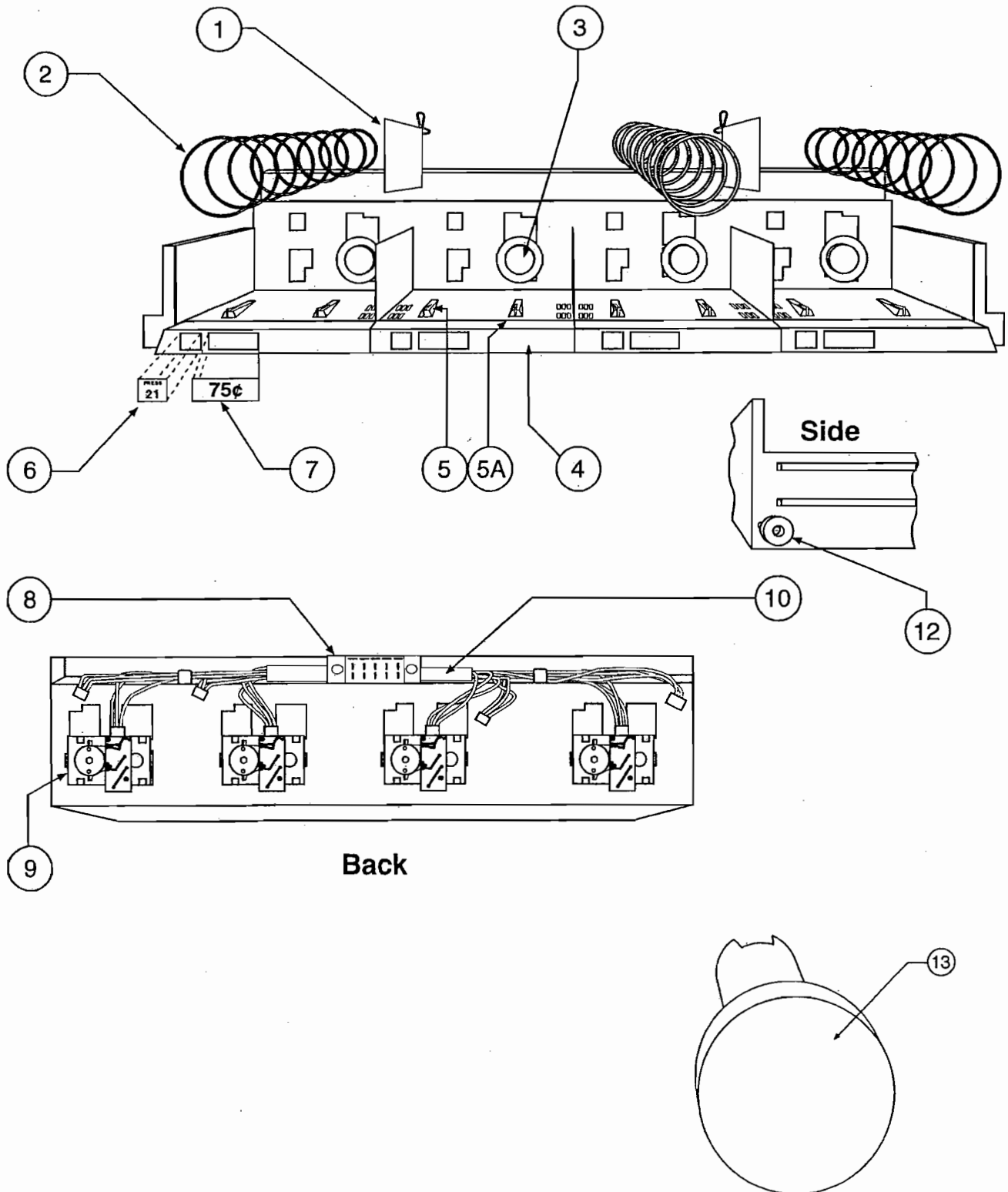

3, 4, or 5 Selection Shelf Assembly

Index No.	5900S Part Number	5900JR Part Number	5900C Part Number	Description	Quantity Per Assembly
	593-1615	594-1615	591-1615	Shelf W/A	REF
	593-1605	594-1604	591-1603	Shelf Assembly - 3/4/5 Select	REF
1	593-1617	Same	Same	Adjustable Shelf Wall - Product	2/2/2
2	490-34	"	"	Pastry Helix - 10 Select	5/4/3
	490-33	"	"	Pastry Helix - 12 Select	5/4/3
	490-32	"	"	Pastry Helix - 15 Select	5/4/3
	593-14	"	"	Helix - 6 Count (for "Lunch Bucket" size items)	5/4/3
3	490-27	"	"	Helix Hub	5/4/3
4	593-613	"	"	Product Guide (Single Price)	5/4/3
	934-501	"	"	Screw	10/8/6
5	593-617	"	"	Helix Guide	10/8/6
6	593-1908	"	"	Assortment - Number Block	1
7	593-1913	"	"	Price Card Assortment	1
8	593-2	"	"	Plug Bracket	1
	979-253	"	"	Plug - 15 Pin Male	1
	979-169	"	"	Pin - Plug Anchoring	1
9	493-1865	"	"	Motor Assembly	5/4/3
	493-4526	"	"	Motor Full Cycle Sensing Switch	5/4/3
10	593-1801	594-1801	594-1801	Shelf Harness Assembly	1
	979-1180	Same	Same	Socket	5/4/4
11	490-1925	"	"	Product Pusher Assortment (Not shown)	1
12	490-5	"	"	Shelf Roller	2
	490-42	"	"	Roller Bushing	2
	934-441	"	"	Screw	2
	924-64	"	"	Nut	2
	201-359	"	"	Canoe Clip (Not Shown)	2
13	593-902	"	"	Hub Removal Tool	1

*For other count helixes available as service parts only, see page 6-2.

Dual Helix Shelf

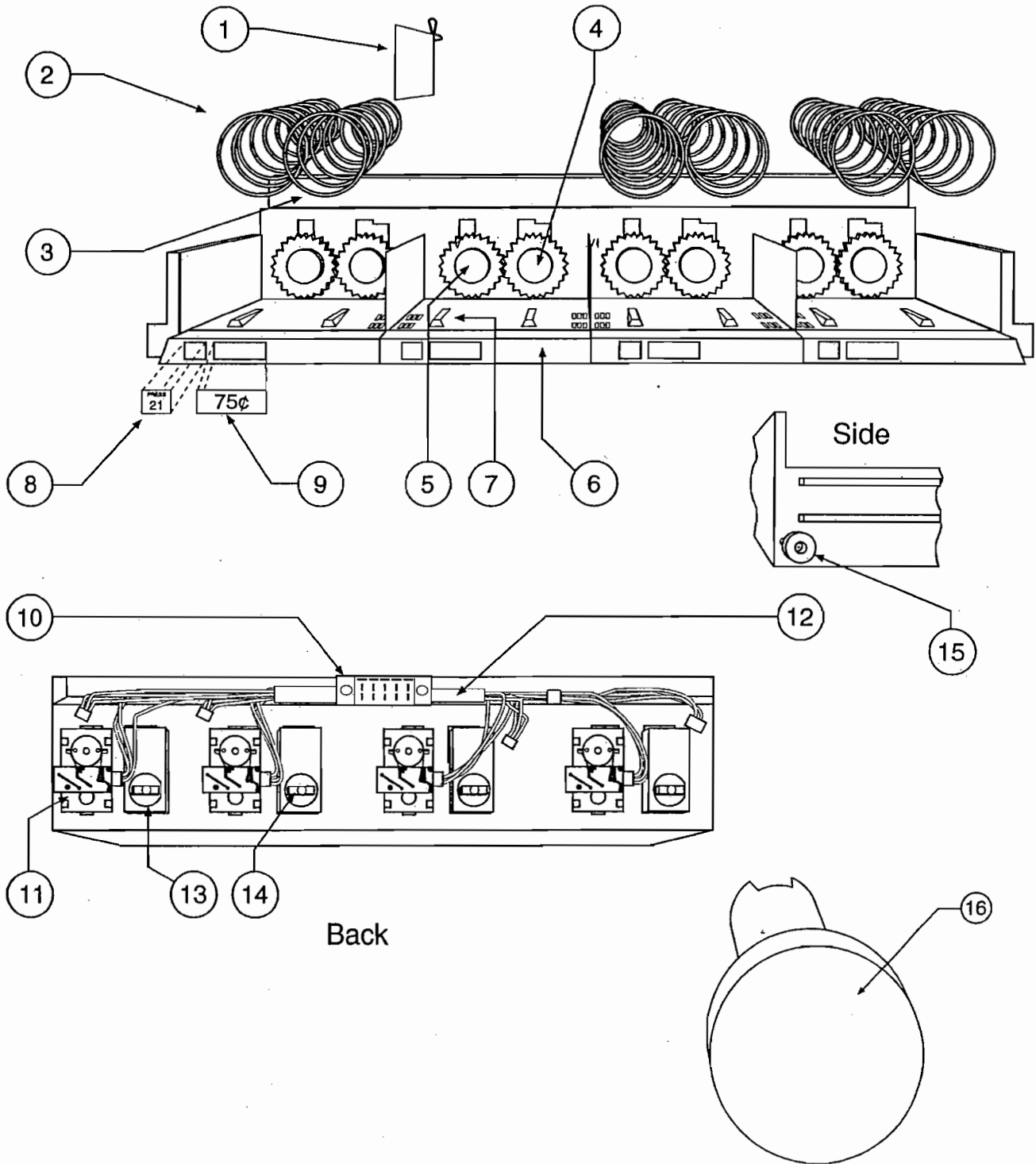

Dual Helix Shelf

Index No.	5900S Part Number	5900JR Part Number	5900C Part Number	Description	Quantity Per Assembly
	593-1615	594-1615	591-1615	Shelf W/A	REF
	593-1600	594-1600	591-1600	Shelf Assembly - Dual Helix 3/4/5 Select	REF
1	593-1617	Same	Same	Adjustable Shelf Wall - Product	1/1/1
2	593-13	"	"	Reverse Helix - 10 Select	5/4/3
	593-12	"	"	Reverse Helix - 12 Select	5/4/3
	593-11	"	"	Reverse Helix - 15 Select	5/4/3
	593-15	"	"	Reverse Helix - 30 Select	5/4/3
3	493-16	"	"	Candy Helix - 10 Select	5/4/3
	493-15	"	"	Candy Helix - 12 Select	5/4/3
	490-31	"	"	Candy Helix - 15 Select	5/4/3
	490-18	"	"	Candy Helix - 30 Select	5/4/3
4	593-616	"	"	Helix Hub - Dual Helix Drive Gear	5/4/3
5	593-615	"	"	Helix Hub - Dual Helix Idler Gear	5/4/3
6	593-613	"	"	Product Guide (Single Price)	5/4/3
	934-501	"	"	Screw	10/8/6
7	593-617	"	"	Helix Guide	10/8/6
8	593-1908	"	"	Assortment - Number Block	1
9	593-1913	"	"	Price Card Assortment	1
10	593-2	"	"	Plug Bracket	1
	979-253	"	"	Plug - 15 Pin Male	1
	979-169	"	"	Pin - Plug Anchoring	1
11	493-1865	"	"	Motor Assembly	5/4/3
	493-4526	"	"	Motor Full Cycle Sensing Switch	5/4/3
12	593-1801	594-1801	594-1801	Shelf Harness Assembly	1
	979-1180	Same	Same	Socket	5/4/4
13	593-618	"	"	Idler - Dual Helix	5/4/3
14	929-1000	"	"	Rivet	5/4/3
15	490-5	"	"	Shelf Roller	2
	490-42	"	"	Roller Bushing	2
	934-441	"	"	Screw	2
	924-64	"	"	Nut	2
	201-359	"	"	Canoe Clip (Not Shown)	2
16	593-902	"	"	Hub Removal Tool	1

Candy Shelf

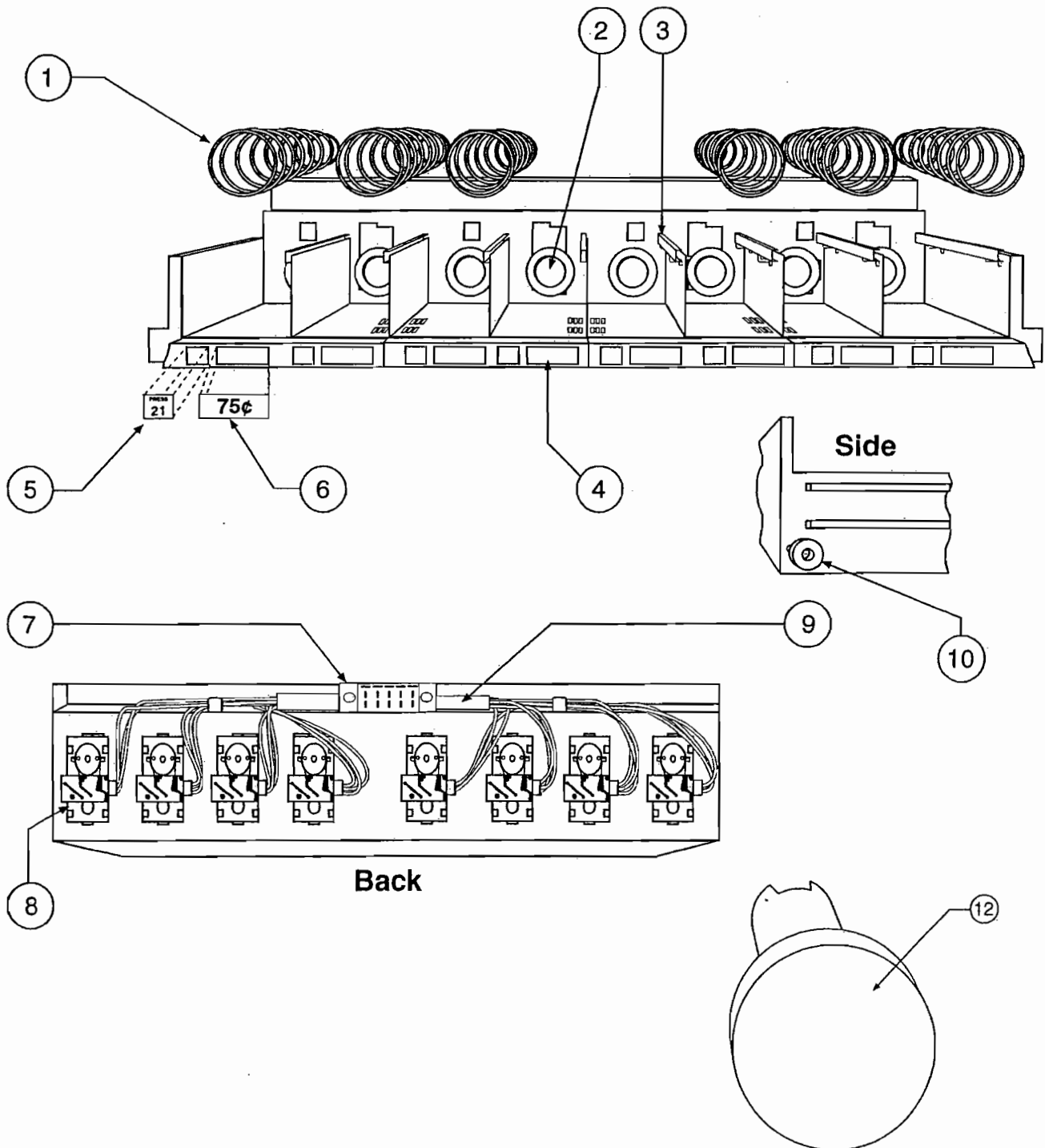

Candy Shelf

Index No.	5900S Part Number	5900JR Part Number	5900C Part Number	Description	Quantity Per Assembly
	593-1615	594-1615	591-1615	Shelf W/A	REF
	593-1610	594-1608	591-1606	Shelf Assembly - Candy 6/8/10 Select	REF
1	493-16	"	"	Candy Helix - 10 Select	10/8/6
	493-15	"	"	Candy Helix - 12 Select	10/8/6
	490-31	"	"	Candy Helix - 15 Select	10/8/6
	490-30	"	"	Candy Helix - 18 Select	10/8/6
	490-29	"	"	Candy Helix - 24 Select	10/8/6
	490-28	"	"	Candy Helix - 30 Select	10/8/6
2	593-616	"	"	Helix Hub	5/4/3
3	593-1616	"	"	Product Adjustment Arm Assembly	10/8/6
	490-8	"	"	Retaining Block	2/2/2
	593-619	"	"	Adjustment Wall Arm	2/2/2
	490-21	"	"	Adjustment Wall	2/2/2
4	593-614	"	"	Product Guide (Dual Price)	5/4/3
	934-501	"	"	Screw	10/8/6
5	593-1908	"	"	Assortment - Number Block	1
6	593-1913	"	"	Price Card Assortment	1
7	593-2	"	"	Plug Bracket	1
	979-253	"	"	Plug - 15 Pin Male	1
	979-169	"	"	Pin - Plug Anchoring	1
8	493-1865	"	"	Motor Assembly	5/4/3
	493-4526	"	"	Motor Full Cycle Sensing Switch	5/4/3
9	593-1801	594-1801	594-1801	Shelf Harness Assembly	1
	979-1180	Same	Same	Socket	5/4/4
10	490-5	"	"	Shelf Roller	2
	490-42	"	"	Roller Bushing	2
	934-441	"	"	Screw	2
	924-64	"	"	Nut	2
11	490-1925	"	"	Product Pusher Assortment (Not Shown)	1
12	593-902	"	"	Hub Removal Tool	1

Gum and Mint Unit

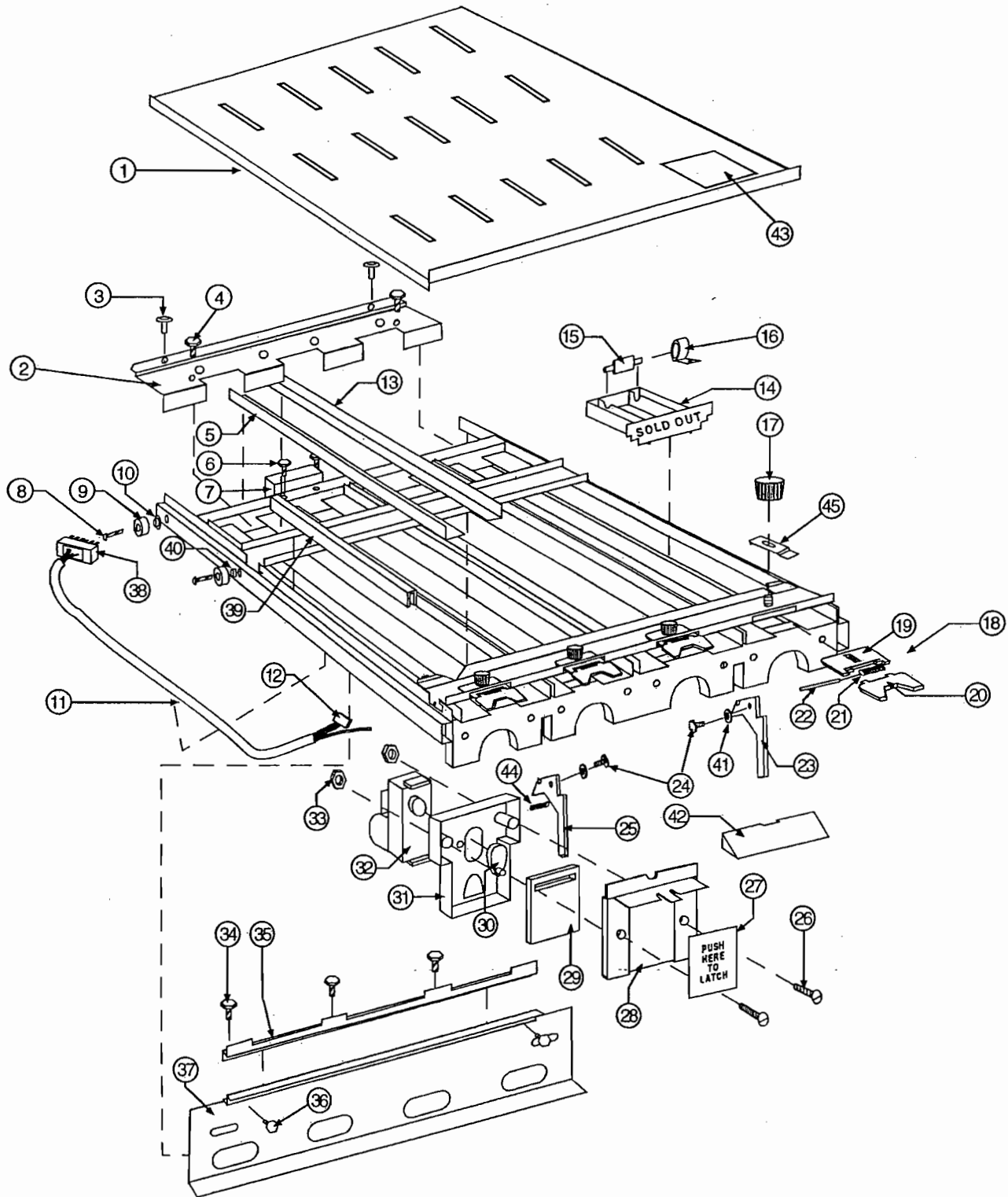

Gum and Mint Unit

Index No.	5900S Part Number	5900JR Part Number	5900C Part Number	Description	Quantity Per Assembly
	593-1715	594-1715	591-1700	Gum and Mint Final Assembly	REF
	593-1710	594-1710	591-1701	Gum and Mint Weld Assembly	REF
1	593-726	594-726	591-700	Cover Gum and Mint Unit	1
2	593-725	594-725	591-706	Retainer - Product Pusher	1
3	201-359	Same	Same	Canoe Clip	4
4	934-307	"	"	Screw - #8 x 3/8"	2
5	593-723	"	"	Product Guide - Adjustable (Left)	2
6	934-307	"	"	Screw - #8 - 3/8"	2
7	593-2	"	"	Plug Bracket Mounting	1
8	934-484	"	"	Screw - 1/4-200 x 3/4"	4
9	490-5	"	"	Roller	4
10	490-6	"	"	Bushing - Roller	2
11	593-1841	"	"	Harness - Gum and Mint	1
12	979-1180	"	"	Socket	5
13	593-724	"	"	Product Guide - Adjustable (Right)	2
14	593-729	"	"	Product Pusher	5/4/3
15	593-733	"	"	Hub - Negator	5/4/3
16	593-730	"	"	Spring - Constant Force	5/4/3
17	593-747	"	"	Torque Knob	5/4/3
18	593-1706	"	"	Flipper Assembly	5/4/3
19	593-731	"	"	Bracket - Flipper Assembly	5/4/3
20	593-732	"	"	Product Flipper	5/4/3
21	593-734	"	"	Spring - Flipper	5/4/3
22	593-728	"	"	Pivot Pin - Flipper	5/4/3
23	593-760-2	"	"	Lever - Latch (Right)	1
24	934-307	"	"	Screw - #8 x 3/8"	2
25	593-760-1	"	NA	Lever - Latch (Left)	1
26	921-325	"	Same	Screw - Machine 8-32, 1-1/8"	10/8/6
27	907-2241	"	"	Decal - "Push to Latch"	2/2/1
28	593-740	"	"	Bezel - Price Card	5/4/3
29	593-743	"	"	Product Ejector	5/4/3
30	593-738	"	"	Crank - Gum and Mint Motor	5/4/3
31	593-739	"	"	Housing - Motor Mounting	5/4/3
32	493-1865	"	"	Motor Assembly	5/4/3
33	924-4	"	"	Nut 8-32	10/8/6
34	593-758	594-748	591-711	Spring Overtravel Prevention Retainer	1
35	934-307	Same	Same	Screw	5/4/3
36	934-307	"	"	Screw	2
37	593-759	594-749	591-712	Bracket - Spring Retainer	1
38	979-253	Same	Same	Plug	1
39	928-3051	"	"	Rubber Gasket	2
40	490-42	"	"	Bushing	2
41	499-466	"	"	Washer - Step	2
42	593-741	"	"	Cover - Price Bezel	5/4/3
43	907-2228	"	"	Label - Gum and Mint Cover	1
44	448-514	"	"	Latch Spring	10/8/6
45	591-420	"	"	Support - Flipper	5/4/3

Refrigeration Unit (Optional)

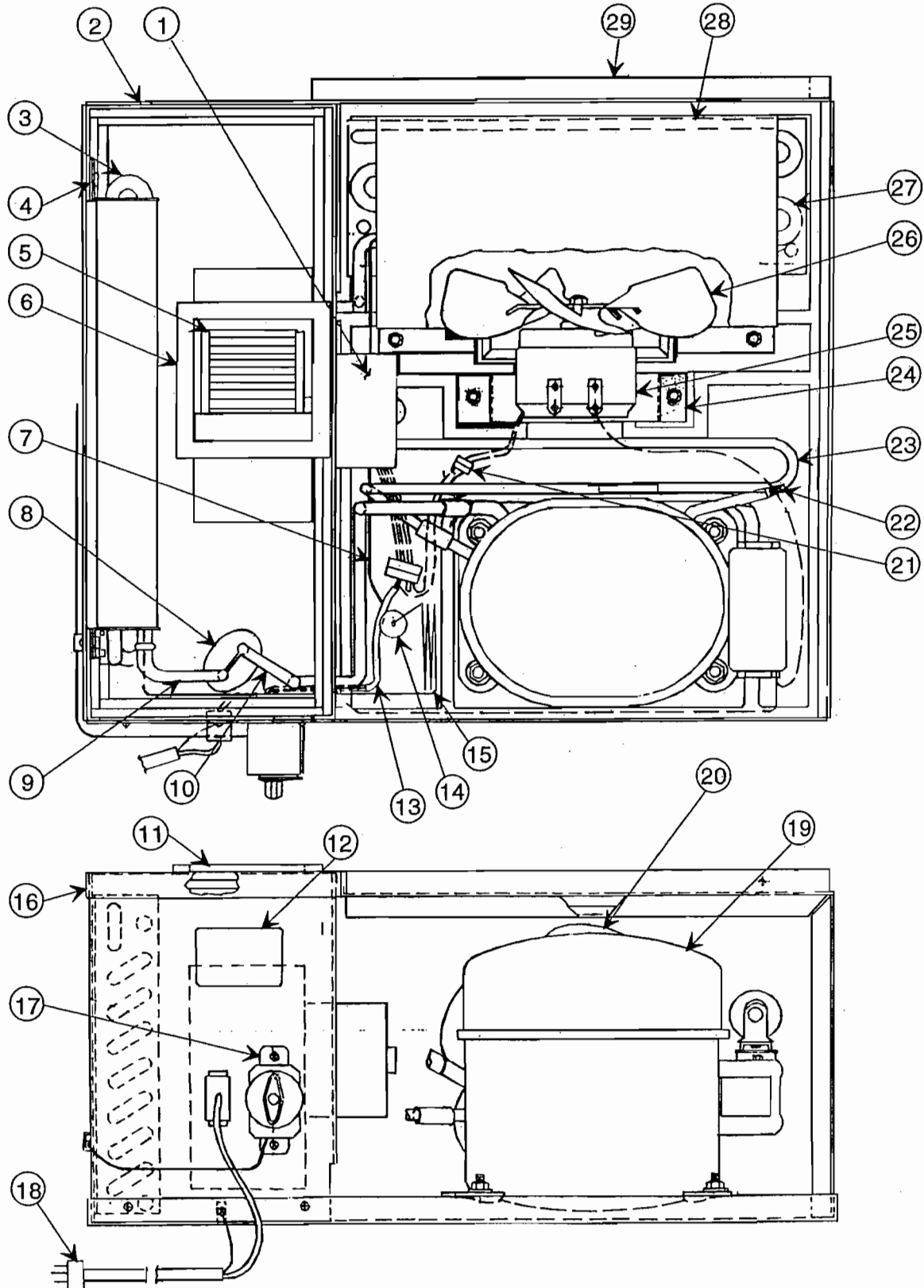

Refrigeration Unit (Optional)

Index Number	Rowe Part Number	Description	Quantity Per Assembly
	595-1205	Refrigeration Unit - R12	REF
	595-21505	Refrigeration Unit (Euro) 240 Volts - R12	REF
	595-01206	Refrigeration Unit - R134A	REF
	595-21541	Refrigeration Unit - 220/240 Volts - R134A	REF
1	595-21528	Evaporator - Blower Motor	1
2	595-20535	Bulkhead, Evaporator	1
	934-448	Screw, Self Tapping	9
3	595-21510	Evaporator	1
	934-486	Screw, Self Tapping	4
	941-62	Nut, Speed	4
4	595-20510	Spacer - Evaporator	2
5	595-21526	Blower Wheel	1
6	595-21527	Scroll	1
7	595-20525	Tube, Condenser to Drier	1
8	111-1217	Accumulator	1
9	595-20523	Tube, Evaporator to Accumulator	1
10	595-20527	Tube, Suction Accumulator to Compressor	1
11	595-20511	Gasket - Evaporator, Output	1
12	906-536	Data Plate - 5900	1
13	595-21511	Harness, Refrigeration - Europe	1
14	595-1201	Drier	1
	595-21543	Drier - R134A	1
15	595-21531	Tube, Capillary	1
16	595-20503	Cover, Evaporator	1
17	595-21507	Thermostat & Bracket Assembly	1
	934-448	Screw, Self Tapping	2
18	595-1800	Line Cord, Refrigeration	1
	595-21512	Line Cord, Refrigeration (Euro)	1
19	595-21509-001	Compressor 115 Volts - R12	1
	595-21509-002	Compressor (Euro) 240 Volts - R12	1
	595-01207	Compressor 115 Volts - R134A	1
	595-21542	Compressor 220/240 Volts - R134A	1
	924-15	Nut	4
	950-337	Washer	4
	448-237	Sleeve - Grommet	4
	448-238	Grommet	4
20	595-20509	Fan - Condenser	1
21	979-1194	Connector, Capacitor	1
22	595-20524	Tube - Process to Compressor	1
23	595-20526	Tube - Discharge Compressor to Condenser	1
24	595-20507	Bracket - Motor Mounting Condenser	1
25	595-21515-001	Motor - Fan, 115V	1
	595-21515-002	Motor - Fan, 230V	1
26	595-20509	Fan - Condenser	1
	924-13	Nut	1
27	595-21521	Condenser	1
28	866-55001	Gasket - Rubber, Sponge	1
29	866-80005	Gasket - Rubber	1

Fig. & Index Number	Rowe Part Number	Description	Quantity Per Assembly
	593-1845-100	Main Controller Assembly - Complete	REF
	593-1826	Circuit Board Assembly - Main Controller (Revised 11/93)	1
	493-811	Base - Main Controller	1
	593-1818	Cover, Main Controller	1
	79800354	EPROM Program Chip (Part Location U11)	1

REFERENCE	DESCRIPTION	PART NUMBER	REFERENCE	DESCRIPTION	PART NUMBER
C33,C34	Cap - 22PF 50V 5%	70028705	R74	Res - 10 OHM 1/4W 5%	79901100
C32	Cap - 1000PF 50V 10%	70028618	R78	Res - 27K 1/4W 5%	79901273
C4, C8	Cap - 2200PF 50V 10%	70028624	R81 - R84	Res - 470 OHM 1/4W 5%	79901471
C3	Cap - .003UF 50V 10%	203A0F5120-3303	R1	Res - 5.12K 1/2W 5%	79908512
C9, C10, C11	Cap - 470PF 50V 10%	70028612	R6	Res - 1.2 OHM 1W 5%	200A021003-01X2
C8, C17, C18, C19	Cap - .1UF 50V 20%	70028649	U2	IC, Volt Reg. Adj. 1.5A	230A-000004962
C21 - 31, C35	Cap - .1UF 50V 20%	70028649	U17	IC, 8 Bit Sink Drive 20V .2A	230A-000002595A
C2, C36	Cap - .1UF 50V 20%	203AL5100-1004	U23	IC, Source Driver 50V .5A	230A-000002981A
C5, C20, C37	Cap - 1UF 35V 10%	203A6E5100-1005	U15	IC, 8 Bit Ser. Latch Drv. 50V .5A	230A-000005841A
C12, C13, C14, C15, C16	Cap - 22UF 25V 20%	203A7D6100-2206	U16	IC, 8 Bit Ser. Latch Drv. 80V .5A	230A-000005841A
C6, C7	Cap - 220UF 25V 20%	203A7D6100-2207	U3	IC, RS232 Drv./ Recv Dual	230A-00LT1181CN
C1	Cap - 470UF 100V 20%	203A7H6000-4707	U18 - 20	IC, Quad 2 inout NAND CMOS	230A-00074HC00N
D11, D13 - 20	Diode - 100v 1A	220A002-01N4002	U22	IC, Non Inv. Hex Buffer	70034050
D1 - D9	Diode - 600V 1.5A	220A015-00GP15J	U10	IC, 3 to 8 Line Decode / Demux	232A-0074HC138N
D12	Diode - 60V 3A	220A005-00SB360	U9	IC, D Flip-Flop Octal, 3-State	232A-0074HC373N
L1	Inductor - 150MH 2A	206A2-1507-0001	U13, U14	IC, D Flip-Flop Octal, 3-State	232A-0074HC374N
MOV1	Varis - 35 VRMS 2.3 Joules	70037506	U12	IC, Timekeeper Sram 2K x 8	70036612
MOV2	Varis - MO 150V 13 Joules	256A-150013-001	U5 - U7	IC, Octal X-Cvr 2-way Async.	232A-0074HC245N
Q2, Q4, Q5	Trans - GP NPN 30V .6A	225A000-MPS2222	U24, U25	IC, Opto Coupled Transi. Output	238A-0000004N37
Q3	Transistor - PNP 80V .5A	70030104	U4	IC, Opto Coupler Tans. Output	70033713
Q1	Transistor NPN 60V 5A	225A002-OTIP120	U8	IC, Undervolt Sensor	30800243
R2, R5	Res - 3.3K 1/8W 5%	79905332	U21	IC, Darlington Array	70036901
R3, R4, R11, R14 - 19	Res - 10K 1/8W 5%	79905103	Y1	Crystal - 4.9152MHZ HC49U W/Slv	25167313
R38 - 44 R46 - 56	Res - 10K 1/8W 5%	79905103	S2 - S6	Switch - 12mm SPST Mom. N.O.	258A-000001F-001
R60, R64 - 66, R71, R73	Res - 10K 1/8W 5%	79905103	S1	Switch - Dip 6 Pos.	258A-901X0T-601
R7	Res - 15K 1/8W 5%	79905153	P5	Con - D-sub 9 pos.	350A02080061-00
R8, R12, R76 R77, R80	Res - 4.7K 1/8W 5%	79905472	P9	Con - Hdr, .156 Break-away 2 pos.	350A26481021-00
R10, R58, R72	Res - 100K 1/8W 5%	79905104	P1	Con - Hdr, .156 Break-away 6 pos.	350A26481061-00
R20 - 27, R37	Res - 20K 1/8W 5%	79905203	P4	Con - Hdr, .156 Break-away 7 pos.	350A26481071-00
R28 - R36	Res - 82K 1/8W 5%	79905823	P3	Con - Hdr, .156 Break-away 8 pos.	350A26481081-00
R45, R69, R79	Res - 1.0K 1/8W 5%	79905102	P8	Con - Hdr, .156 Break-away 16 pos.	350A26481161-00
R63, R85	Res - 47K 1/8W 5%	79905473	P2	Con - Hdr, .156 Break-away 17 pos.	350A26481171-00
R57, R59	Res - 330 OHM 1/8W 5%	79905331	P7	Con - Hdr, .156 Break-away 19 pos.	350A26481191-00
R9, R61, R62	Res - 100 OHM 1/8W 5%	79905101	U1	IC, Microprocessor 68HC11	236A-068HC11A1P
R67	Res - 10M 1/4W 5%	79901106	R13, R68	Res - 200 OHM 1/8W 5%	79905201
R70	Res - 18 OHM 1/4W 5%	79901180	D10	Diode - Zener 27V 1W 10%	222A002-1N4750A

Harness list

INTERNAL HARNESS ASSEMBLIES

493-1856	Dom. Line Cord
593-1800	Printer Harness
593-1801	Shelf-10 Motor / 5 Motor
593-1839	Main Cabinet
593-1841	Gum and Mint Assembly
594-1801	Shelf-8 Motor / 6 Motor / 4 Motor / 3 Motor
595-1800	Dom. Refrig. Line Cord
595-1801	Dom. Refrig. Harness
595-21511	Euro. Refrig. Harness
595-21512	Euro. Refrig. Line Cord
595-21519	Euro. Coin Mech. Power
595-21524	Euro. Power Switch

POINT TO POINT HARNESSES

	From	To
493-1885	Fluorescent Light	Cabinet Panel
493-1857	Main Line Switch	Main Power Supply Harness
493-1869	B/A Power	Cabinet Panel
493-1879	Power Switch	Line Filter
593-1804	Keypad.	Display
593-1806	Coin Mech	Controller P2
593-1807	Power Box	Controller P1
593-1808	A.C. Switch	Power Box
593-1811	EMI Filter	Light Conn. and A.C. Socket
593-1813	B/A Cabinet	Controller P4
593-1828	Display	Cab. Panel
593-1829	Cabinet Panel	Controller P6
593-1830	Rowe B/A	B/A Data Harness
593-1832	Fan.	Power Box
593-1833	Mars B/A	B/A Data Harness
593-1836	B/A Interconnect	B/A Cable
595-21520	Euro. Coin Mech Data	Controller P3
595-21519	Euro. Coin Mech Power	24V Splice