

AUTOMATIC PRODUCTS

HOT BEVERAGE MERCHANDISER

MODEL 213 OPERATING SERVICE MANUAL

PLEASE

**DO NOT REMOVE
MANUAL FROM
MACHINE**

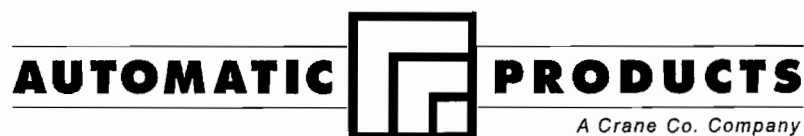

Express Warranty

Automatic Products international ltd. (APi) expressly warrants these automatic merchandisers (the "Unit"), manufactured by it, to be free under normal use and service from defects in material or workmanship for a period of two (2) years from the date of delivery of this Unit to the original purchaser. This warranty extends only to the original purchaser of the Unit. The exclusive remedy for this warranty is limited to the repair or replacement, at APi's sole option, of any part or parts of the Unit that are returned to APi or to the authorized dealer or distributor of APi from whom the unit was purchased with all transportation charges prepaid, and which, on APi's examination, shall, conclusively appear to have been defective. This warranty does not:

- a. extend to any Unit, or part thereof, that was subjected to misuse, neglect, or accident by other than APi after its delivery to the original purchaser;
- b. extend to any Unit, or part thereof, that was modified, altered, incorrectly wired or improperly installed by anyone other than APi or used in violation of the instructions provided by APi;
- c. extend to a Unit which has been repaired or altered by anyone other than APi or authorized dealer/distributor;
- d. extend to a Unit which has had the serial number removed, defaced or otherwise altered;
- e. extend to plastic or glass windows, lamps, fluorescent tubes and water contact parts;
- f. extend to any unit used outdoors
- g. extend to accessories used with the Unit that were manufactured by some person or entity other than APi.

API DISCLAIMS ALL OTHER WARRANTIES OF ANY KIND AS TO THE UNIT AND ALL WARRANTIES OF ANY KIND AS TO ANY ACCESSORIES. THIS DISCLAIMER OF WARRANTIES INCLUDES ANY EXPRESS WARRANTIES OTHER THAN THE LIMITED WARRANTY PROVIDED ABOVE AS TO THE UNIT AND ALL IMPLIED WARRANTIES OF MERCHANTABILITY AND FITNESS FOR A PARTICULAR PURPOSE AS TO THE UNIT AND ANY ACCESSORIES. UNDER NO CIRCUMSTANCES SHALL API BE RESPONSIBLE FOR ANY INCIDENTAL, CONSEQUENTIAL OR SPECIAL DAMAGES, LOSSES OR EXPENSES ARISING FROM OR IN CONNECTION WITH THE USE OF, OR THE INABILITY TO USE, THE GOODS FOR ANY PURPOSE WHATSOEVER. No representative of APi or any other person is authorized to assume for APi, or agree to on the behalf of APi, any other liability or warranty in connection with the sale of this Unit.

APi reserves the right to make any changes or improvements in its products without notice and without obligation, and without being required to make corresponding changes or improvements in Unit theretofore manufactured or sold.



300 Jacksonville Rd. ♦ Warminster, PA. ♦ 18974

TABLE OF CONTENTS AP 213 SERVICE MANUAL

INTRODUCTION	1.01
HOW TO USE THIS MANUAL	1.01
FEATURES OF AP 213 HOT DRINK MERCHANDISER	1.02
SPECIFICATIONS	1.02
SOFTWARE IDENTIFICATION AND LABELS	1.03
INSTALLATION AND SET-UP INSTRUCTIONS	1.05
CANISTER RACK INDEX CHART	1.07
RACK CONFIGURATION Ø	1.08
RACK CONFIGURATION 1	1.14
RACK CONFIGURATION A	1.20
RACK CONFIGURATION 2	1.25
213 ELECTRONICS CONTROL SYSTEM - INTRODUCTION	2.01
USE OF KEYBOARD	2.02
MODE 1 - DISPLAY REPORT	2.03
MIS FLOWCHART BY PRICELINE	2.04
MIS FLOWCHART BY PRODUCT INFORMATION	2.05
MODE 2 - TEST VEND	2.03
MODE 3 - FLUSH CYCLE	2.06
MODE 4 - SET PRICES FOR LARGE DRINK	2.06
MODE 5 - SET PRICE REGULAR SIZE	2.06
MODE 6 - DIAGNOSTICS	2.07
MODE 7 - CHANNEL TIMED TEST	2.07
MODE 8 - CHANNEL CONTINUOUS TEST	2.07
MODE 9-UPLOAD SETTINGS	2.08
MODE 10-DOWNLOAD SETTINGS	2.08
MACHINE TO MACHINE UPLOAD/DOWNLOAD	2.08
MODE 11 - MACHINE CONFIGURATION	2.09
MODE 12 - SET TIME CHANNELS	2.10
MODE 13 - SET OPTIONS	2.12
MODE 14 - SET DISCOUNT BITS	2.13
MODE 16 - LOAD STANDARD SETTINGS	2.13
MODE 17 - PROGRAMMING USER MESSAGE	2.14
APPENDIX I - GRAM THROWS AND WATER VOLUMES	2.15
APPENDIX II: 213 LOGIC SWITCH NUMBERS	2.16
APPENDIX III: "OUT OF ORDER" CODES	2.17
APPENDIX IV: CHANNEL APPLICATION CHART	2.18
SERVICE INDEX	3.01

To achieve the most trouble-free operation from your AP213 Hot Drink Merchandiser, it is recommended that this service manual be thoroughly read and the instructions followed pertaining to installation, servicing and maintaining of the unit.

Should you have questions pertaining to this manual or the vendor, please contact your API/RMI distributor or write directly to:

Technical Service Dept.
Automatic Products Intl.
300 Jacksonville Road
Warminster, PA 18974

© 1994 Automatic Products international, Ltd

FEATURES OF AP 213 HOT DRINK MERCHANDISER

STANDARD FEATURES

- Total of seven primary selection of which five are prime selections, each with three programmable strengths plus chocolate and SGC or soup depending on rack configuration.
- Dual adjustable cup separators.
- 12 ounce brewer with fixed filter base.
- Easy to use color coded selection buttons for variable strength products.
- Preset for either one or two cup sizes.
- Improved high velocity exhaust system.
- Over 840 selections possible.
- Coffee strength variable by changing coffee throw.
- Artificial sweetener available.
- Variable strength additives.
- Easy to change selection labels.
- Selection lamps and audible tone feedback for touch sensitive buttons.
- Coins for the next vend can be inserted before the end of the current vend.
- Auto flush every 12 hours

PRICING / CREDIT

- All selections of each size individually priced.
- Two price levels for variable strength selections.
- Separate discount pricing structure available.
- Programmable winner mode
- Forced vend and bill escrow features.
- Full accountability including discount cash meters, ten separate price line counters or accountability by beverage and size.

SCROLLING DISPLAY

- User friendly scrolling display to help with the selection process and provide customer feedback.
- Programmable for stand-by "operator" messages, up to 85 characters long.

OPTIONS

- Fresh brewed tea
- Whipped Soluble Gourmet Coffee (SGC)
- USE YOUR OWN CUP option with or without discount feature
- 24V (standard) or 110V capability for coin mech or validator
- Slow return vend door dampener
- MIS information retrieval and upload/download
- Cold water shot
- Kick plate
- Bean hopper filler plate

SPECIFICATIONS

DIMENSIONS:

Height: 72" Depth: 31" Width: 38"

ELECTRICAL AND WATER REQUIREMENTS:

Electrical: 120 Volts; 60 Hz; 16 Amps
Water: Potable cold water, 20 psi minimum

SHIPPING WEIGHT

Freeze-dried 460 lbs.
Loose ground 500 lbs.
Grinder 560 lbs.

MODEL AND CAPACITIES

Ingredient:	Capacities lbs.					
	DG	G	GLG	DH	LG	FD
Regular Coffee Beans	11	16	11.5	-	-	-
Decaf. Coffee Beans	5	-	-	-	-	-
Regular Ground Coffee	-	-	-	11	12	-
Decaf. Ground Coffee	-	-	3.5	4.5	-	-
Soluble 'FD' Coffee*(2)	-	-	-	-	3	-
Soluble 'FD' Decaf*(1)	1.5	1.5	1.5	1.5	1.5	-
Tea Leaf-Fresh brewed	2.5	2.5	2.5	2.5	2.5	-
or Instant*(1)	1.5	1.5	1.5	1.5	1.5	-
Sugar*(2)	8	8	8	8	8	8
Sugar Substitute*(1)	10oz	10oz	10oz	10oz	10oz	10
Whitener*(2)	4	4	4	4	4	4
Chocolate (4)	12	12	12	12	12	12
SGC *(2)	4	4	4	4	4	4
Soup *(2)	4	4	4	4	4	4

* Canisters may be expanded
(#) = number of canister levels (Incl. base + expanded)

CUP MODELS AND CAPACITIES

Cup Size	Large Cabinet	Small Cabinet	Manufacturer Cup #
7 oz.	656	429	Swt♥ PV577, IMP SVR-0070
8¼ oz.	590	378	Swt♥ PV588, IMP SVR-0080 Conf Cup 210-2000AV
8 oz. insul	350	251	Swt♥ 8XTX
9 oz.	552	356	Swt♥ PV509, IMP SVR-0090
10 oz.	543	354	IMP SVR-10
12 oz. tall	533	341	IMP SVR-0120A
12 oz. squat	552	352	IMP SVS-0120 Swt♥ PV512T Conf Cup 355-2000AV
12 oz. squat	334	228	International HM1200
12 oz. squat	549	366	Swt♥ PV512
12 oz insul tall-squat	230	158	Swt♥ V12TX
12 oz. insul	321	203	Swt♥ V12X

SOFTWARE IDENTIFICATION AND LABELS

The software revision for Model 213 will be known as "Version C" and can be identified by a lilac (light purple) label on the EPROM on the logic board. All revisions of the dual cup software will be identified with a LETTER in the third position as compared to 'standard' software (non dual cup) which will always have a NUMBER in the third position - see example below. The other digits on the chip label also have specific meanings which are explained in the chart on the next page.

EXAMPLE - SOFTWARE LABEL

DATECODE →	060197060197
ORDER # →	36901
CHIP # →	00CAL8BC

This software provides a maximum of seven prime selections of which five may feature three strengths. Selections can include fresh brewed coffee, regular and decaffeinated, chocolate, a Custom Select Coffee preset for Cafe Mocha - a combination of coffee and chocolate, plus a minimum of one Soluble Gourmet Coffee (SGC). Fresh brewed tea or soluble tea is also available in three strengths and each of the selections is available with three levels of lightener, sugar or sugar substitute. Custom Select Coffee, which offers the operator the ability to combine a number of ingredients already in the machine to produce a premium drink such as Cafe Mocha or Balanced Blend™ or an additional SGC are also available as an added selection. The combinations of drinks available in each machine is determined by the recipes present in the particular software for each machine. See MODE 12, page 2.10 for a further explanation of a recipe.

Another change that increases the flexibility of the AP213 is the possibility of four different canister rack configurations. These four canister rack configurations are designated by a number that represents the number of mixing bowls or troughs, and the number of canisters in each section, reading the rack from left to right. An example would be a standard canister rack, from left to right: chocolate, soup, creme, sugar, sugar sub, soluble decaf and tea. This would be represented as 1-1-5. The chocolate and soup each have their own mixing bowl, while the balance of the canisters are mixed along with the fresh brewed coffee in a common mixing channel. See figure below. For the layout of additional canister rack configuration options, see the index chart on page 1.07. This will also direct you to the correct configuration chart, recipes, label assignments and canister assignments.

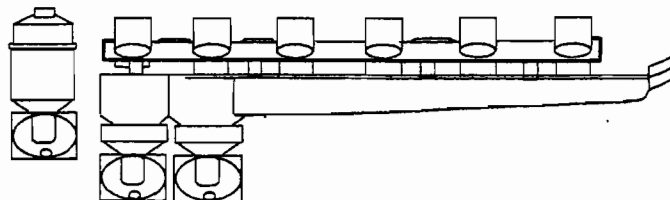

1 - 1 - 5

DEFINITIONS OF INFORMATION CONTAINED ON EPROM LABEL

DIGIT	FUNCTION	DESCRIPTION		
0 (digit 1)	CANISTER RACK CONFIGURATION	0 = STANDARD RACK CONFIGURATION 1-1-5 1 = SPLIT TROUGH - SOUP/SGC + 2 SOLUBLE GOURMETS 1-1-2-3 2 = SPLIT TROUGH - SOUP/SGC + 1 SOLUBLE GOURMET 1-1-1-4 A = SPLIT TROUGH - 2 SOLUBLE GOURMETS 1-2-4		
0 (digit 2)	INDICATES TYPE OF MIS INFORMATION THAT IS RECORDED	0= 10 PRICE LINES (See MODE 1, page 3.03 (step 12), 3.04 & 3.05) 5= TOTALS BY PRODUCT BY SIZE		
C (digit 3)	SOFTWARE PROGRAM VERSION	203 Dual Cup EPROM VERSION 'A' or 'B' 213 EPROM VERSION - 'C' 213 EPROM VERSION - 'D' [DISCONTINUED]		
A (digit 4)	DIGIT #4 INDICATES FACTORY SETTING OF MODE 11, OPTIONS 3 & 5	THIS DIGIT SETS TWO DIFFERENT FUNCTIONS: 1. ON MACHINE SELECTION PANEL, THE #4 SELECTION (4TH ROW DOWN) CAN BE SET TO EITHER DISPENSE A CSC OR SGC BEVERAGE. 2. MACHINE CAN OPERATE EITHER ONE OR TWO CUP SIZES. LETTER = 'YES' FOR CUSTOM SELECT COFFEE (CSC) - IN 4TH SELECTION NUMBER = 'NO' FOR SOLUBLE GOURMET COFFEE (SGC) IN 4TH SELECTION		
	↓ IF POSITION 4 IS ↓	MODE 11, OPTION 3 = ↓ MODE 11, OPTION 5 = ↓		
	A =	CSC ON (setting →) YES 2 CUP SIZES (setting →) NO		
	B =	CSC ON (setting →) YES 1 CUP SIZE (setting →) YES		
	0 =	CSC OFF (setting →) NO 2 CUP SIZES (setting →) NO		
	1 =	CSC OFF (setting →) NO 1 CUP SIZE (setting →) YES		
	Letter 'K' or Higher =	CUSTOM CHIP		
L (digit 5)	LARGE CUP SIZE	L= 12 oz 7= 7 oz J= 10 oz 6= 6 oz 9= 9 oz 8= 8 1/4 oz		
8 (digit 6)	SMALL CUP SIZE	L= 12 oz 8= 8 1/4 oz 0 = None - one cup size setup using above digit 5 setting for both dispensers J= 10 oz 7= 7 oz 9= 9 oz 6= 6 oz		
B (digit 7)	TEA CONFIGURATION	B= Fresh brew F= Freeze-dried X= Disabled (priced at 99.99) Z= Tea replaced with soluble gourmet (used in Rack Configuration 1 only) Y= Tea replaced with soluble gourmet & without 3rd SGC programmed (used in Rack Configuration 1 only)		
C (digit 8)	COFFEE CONFIGURATIONS	<table style="width: 100%; border: none;"> <tr> <td style="width: 50%; vertical-align: top;"> A= Grinder B= Grinder & FD Decaf C= Dual Grinder D= Dual Grinder & FD Decaf E= Grinder w/Loose Ground F= Grinder w/LG & FD Decaf H= All Freeze-dried w/o extension rack J= Grinder with FD Decaf on swing-out </td> <td style="width: 50%; vertical-align: top;"> L= All Freeze Dry w/extension rack - Cof 1 & 2 M= All Freeze Dry w/extension rack - Cof 1&2&3 2= Loose Ground (single hopper) 3= Loose Ground (single hopper) & FD Decaf 4= Dual Hopper (both loose ground) 5= Dual Hopper (both loose ground) & FD Decaf </td> </tr> </table>	A= Grinder B= Grinder & FD Decaf C= Dual Grinder D= Dual Grinder & FD Decaf E= Grinder w/Loose Ground F= Grinder w/LG & FD Decaf H= All Freeze-dried w/o extension rack J= Grinder with FD Decaf on swing-out	L= All Freeze Dry w/extension rack - Cof 1 & 2 M= All Freeze Dry w/extension rack - Cof 1&2&3 2= Loose Ground (single hopper) 3= Loose Ground (single hopper) & FD Decaf 4= Dual Hopper (both loose ground) 5= Dual Hopper (both loose ground) & FD Decaf
A= Grinder B= Grinder & FD Decaf C= Dual Grinder D= Dual Grinder & FD Decaf E= Grinder w/Loose Ground F= Grinder w/LG & FD Decaf H= All Freeze-dried w/o extension rack J= Grinder with FD Decaf on swing-out	L= All Freeze Dry w/extension rack - Cof 1 & 2 M= All Freeze Dry w/extension rack - Cof 1&2&3 2= Loose Ground (single hopper) 3= Loose Ground (single hopper) & FD Decaf 4= Dual Hopper (both loose ground) 5= Dual Hopper (both loose ground) & FD Decaf			

AP 213 INSTALLATION AND SET-UP INSTRUCTIONS INSTALLATION

Unpack the vendor:

1. Remove shipping carton and plastic bag from vendor. Inspect exterior of cabinet for damage. If damaged, a shipping damage report should be filed with carrier.
2. Remove clip from lock handle and open front door. If machine is equipped with a lock, the keys will be in the cupwell. Inspect cabinet interior for evidence of damage.
3. Remove cardboard canister rack insert and all packing tape from coffee hopper swing out bracket, cup dispenser door, commodity trough and steam deflector, overflow and grounds waste bucket floats.
4. Remove all cartons from floor of machine. These cartons may contain the kick plate, grinder swing out bracket, coffee or bean hoppers.

LOCATION SITE REQUIREMENTS

This vendor requires an external source of water and electricity for operation. The minimum requirements for these utilities are as follows:

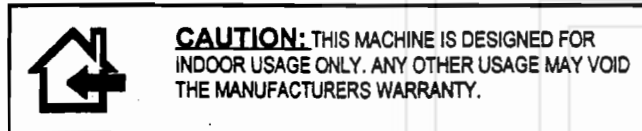

WATER

The installation site must have a cold drinking water supply line that can be permanently coupled to the vendor. The water supply line should be ½ inch minimum diameter and be equipped with a manual shutoff within six feet of the machine. Water pressure should maintain 20 psi minimum while the vendor is taking on water. If water pressure exceeds 90 psi, a pressure regulator should be installed in the line. The standard plumbing connection shipped with the machine is a 3/8" male flare fitting.

◆ INSURE THAT THE WATER SHUT OFF LEVER THAT'S ON THE INLET WATER FILTER HEAD ASM IN THE MACHINE IS CLOSED BEFORE HOOK UP OF WATER SUPPLY (TURN LEVER CCW).

ELECTRICITY

A dedicated grounded electrical outlet rated at 120 volts, 60Hz, single phase and capable of delivering 20 amperes must be available within six feet of the vendor. Only a receptacle that contains a right angle neutral should be used and the H.B.M. should be the only unit in this outlet.

SET-UP INSTRUCTIONS

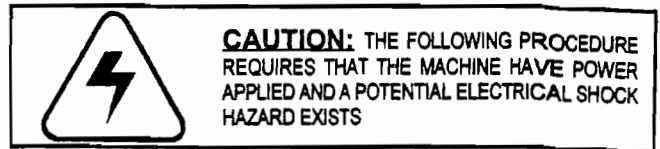

Set up the vendor at the location as follows:

1. On power panel, set all switches to the OFF positions.
2. Carefully level the vendor using the adjustable leg levelers and a level on the top of machine to check from front to back and side to side.
3. If machine is not equipped with a bean grinder, swing coffee hopper out and install hopper. Be sure to engage auger driver with motor drive pin.
4. If machine is equipped with a bean grinder, swing out bracket assembly and hopper will be packed separately and placed on the floor of the machine. After unpacking, remove the bottom 3/8" bolt on the bracket hinge used for the swing out asm. Install the grinder swing out asm on the hinge bracket and connect the electrical harness and replace the bolt. Be sure to secure the sliding gate (located on the sloped surface of the bean hopper) in the fully open position to allow beans into the grinder(s). Install coffee delivery chute to bottom of swing out bracket and do not tightening wing nuts yet.
Push swing out asm against brewer until it latches over roller bracket located on brewer asm. Check roller bracket adjustment to insure swing out bracket holds in place. Position the bottom opening of the coffee chute over the center of the brew chamber for best possible delivery of grounds to brewer then tighten wing nuts.
5. On the bottom of water tank asm, make sure the drain valve is closed. Install water filter cartridge (if so equipped). On the filter head asm, turn the water lever on by rotating it clockwise.
6. Remove shipping screw from brewer cam/switch cover. Locate shipping bolt behind brewer latch & remove using a 3/8" socket wrench or driver. Remove all shipping screws from cup dispenser asm.
7. Connect the vendor to the water supply line using 3/8" O.D. soft copper tubing allowing one complete coil approximately three feet in diameter between the water supply line and vendor to allow movement of the vendor for cleaning and to reduce noise due to water pressure surges.

8. Plug machine into a 120V, 20A receptacle. Set all power switches to the ON position. Check that the tank starts to fill and that there are no leaks. The cup spiral motor will run for thirty seconds or until the cup present switches are depressed. The machine is equipped with a safety feature - if the inlet water valve is on for more than 90 seconds, it will put the machine 'OUT OF ORDER'. To complete the filling of the heater water tank, lift and release the bucket switch to reset the 90 second timer. It may be necessary to reset the 90 second timer twice in order to fill tank.
- ◆ DO NOT GROUND THE PROBE WHILE THE TANK IS FILLING. THIS WILL SIGNAL THE LOGIC BOARD THAT THE TANK IS FULL AND THE HEATERS WILL BE TURNED ON REGARDLESS OF THE LEVEL OF WATER IN THE TANK.
9. Remove packing tie downs holding the humidity bar.
10. Loosen the two screws holding the brewer grounds splash guard on the front of brewer. The shield is designed to be able to swing a little as the spent grounds fall against it.
11. Install grounds bucket liner (supplied). Install grounds bucket behind front flange of rear splash guard. Be sure that the float is inside the bucket.
12. Install overflow bucket against guide on lower left corner of machine. Be sure that the float and overflow hose are inside the bucket.
13. Open cup dispenser doors and load with cups. Cup dispensers are set to size at the factory according to original order. If other cups size is desired, refer to service section for adjustments.
14. Install the coin mech and bill validator, if not already equipped. Connect all harnesses. See decal on coin mech enclosure for list of acceptable coin mechanisms.
- ◆ 213 H.B.M. IS CAPABLE OF RUNNING EITHER A 110 OR 24 VOLTS COIN MECH AND/OR VALIDATOR.



CAUTION: DO NOT USE A 24 VOLT 12 PIN COIN MECH IN THE MACHINE, ELECTRONIC DAMAGE CAN RESULT.

VERY IMPORTANT STEP

READ READ READ

15. Using the drawings of the canister racks on page 1.07, identify your machine configuration. Once you have identified your specific machine, go to the page that is indicated in that box. On that page you will find Mode 11 machine configuration chart with settings related to only this machine. Next, a drawing with selection panel label assignments, then a drawing showing the product canisters / troughs / whippers and wiring assignments. The following pages in that section will pertain to recipe timing charts for your specific machine. The first letter or number on the software IC (EPROM) label will also define the rack version.

Please note that the recipes listed next to each label position on the selector panel layout correspond to the selection codes listed at the top of the channel application chart, Appendix IV, page 2.18 .

- ◆ FOR STEPS 16 AND 17 BELOW, USE STEP 15 ABOVE TO HELP YOU DETERMINE WHAT PRODUCTS GOES INTO WHICH CANISTERS/ HOPPERS AND WHERE TO LOCATE THE PRODUCT LABELS ON THE SELECTION PANEL.

16. Fill canisters and hoppers with product.
17. Access selector assembly by swinging out cup dispenser and lowering logic control board. If the pre-installed condiment or start button labels need to be replaced, the LED board must be removed to gain access to slot opening for labels. Install price labels on selection labels and insert into appropriate positions. Refer to the diagram in the rack configuration section to determine the correct position for each beverage label (see page 1.09 which will direct you to your rack layout and label assignments.

REFER TO THE MANUAL OPERATING SECTION FOR FURTHER INFORMATION ON STEPS 20 THROUGH 22 BELOW.

20. Access **MODE 11** using the security key on the inside of the door and check that the configuration and options are set correctly for the machine. Proceed to **MODE 13** & set payment options. If discount mode is being used, selections being discounted must be assigned in **MODE 14**.

- ◆ The correct function of the security key switch is: ON then OFF - the key should always be in the position where key can be removed.

21. Set selection prices by accessing **MODE 4 & 5** and assigning prices to selections. Mild and regular strength beverages are automatically assigned the same price while each strong beverage may be assigned a different price.

- ◆ **SETTING PRICES TO 0.00 WILL SET A SELECTION TO FREE VEND.**

- ◆ **SETTING A PRICE TO 99.99 WILL DISABLE A SELECTION AND CAUSE THE MESSAGE "MAKE ANOTHER SELECTION" TO APPEAR WHEN THE SELECTION IS PRESSED. THIS IS USEFUL FOR BLOCKING UNUSED SELECTIONS OR DISABLING A SELECTION WHEN IT IS OUT OF ORDER.**

- ◆ **BOTH MODE 4 AND 5 MUST BE SET FOR THE LARGE AND REGULAR DRINKS TO VEND CORRECTLY.**

22. Adjust commodities for the correct throw for the large drink only by accessing **MODE 12** (see page 2.10). After confirming that the times for liquids are correct, cup levels should be adjusted using flow restrictor on each commodity valve except for the brew water valve which must be adjusted in the program..

- ◆ **ALL INGREDIENT SETTINGS TIMES ARE MADE FOR THE LARGE DRINK. THE FACTORY SETTINGS FOR THE DRINK SIZES CAN BE DETERMINED BY CHECKING THE LABEL ON THE SOFTWARE. SEE CHART, PAGE 1.03**

23. After completing the product adjustments, install the commodity chutes. Install the humidity bar (heater) on the canister rack so that the tabs on the humidity bar fit into their respective slots between the canisters. Connect the humidity bar harness to the machine harness (located to the left of the chocolate canister).

24. Install chocolate whipper mixing bowl cover.

25. Test all selections and additives using cash credit with coins and bills.

ADJUSTING COMMODITY AND LIQUID AMOUNTS

Entering **MODE 12** provides access to the channels which control the dispense times of all ingredients. The dispense time of each commodity and its sequence in the vend cycle is controlled by the microprocessor. Precise time adjustments determine the exact amount of ingredients dispensed. This exact time sequence ability enables accuracy to 1/100 of a second.

Each channel may have up to three separate settings within each channel. The settings are accessed by pressing the start/enter selection. The three settings are **START**, **DURATION** and **MODIFIER**. Each of these settings can be adjusted by increasing or decreasing the digits shown on the scrolling display by pressing the increase digit (coffee strong) or the next digit (coffee regular) buttons.

The **START** time of each channel indicates the time each function or commodity begins within each vend cycle. All times are permanently stored to guarantee the correct sequence of operation.

The **DURATION** determines the length of time within the vend cycle that each channel will operate. The amount of ingredient for a medium strength selection is controlled by adjusting the duration. After confirming that the duration for liquids are set correctly, cup levels should be set by adjusting the flow restrictor on the commodity valves.

Some product channels have a third setting - a **MODIFIER**. This modifier appears in the scrolling display as a number below 1.00 (100%). The **MODIFIER** value is the percentage of increase or decrease in ingredient throw for a strong or mild selection. For example, a **MODIFIER** of .25 on channel 15 (brewed coffee-sugar) means that for an extra sugar selection the sugar motor will run 25% longer and for a lesser sugar selection, the motor will run for a period of time that is 25% shorter.

It is important to press **START/ENTER** after changing any one of these settings and returning to **MODE 12** to ensure that all new values are entered. See Timing Chart #1 below.

♦ **THROUGHOUT THIS MANUAL THE WORD START OR ENTER ALWAYS REFERS TO THE RIGHT HAND OR LARGE START BUTTON.**

Each channel can be tested by pressing the **MODE 12 CHANNEL TEST** switch (middle sugar).

♦ *Once the durations for the additives (lightener, sugar, sugar substitute) have been set correctly for the brewed coffee channels, these duration times can be duplicated and entered into the channels for freeze-dried products and tea selections to simplify the set up procedure.*

♦ *All ingredient throws set in MODE 12 are the actual throw used for the middle or regular button on the large size cup.*

♦ *Standard times, settings and prices can be reloaded using MODE 16. See MODE 16 for more information.*

♦ *Certain channels may be used in different recipes to control different functions. Confirm that you are using the correct recipe list for your machine.*

FOR ADDITIONAL INFORMATION ON CHANNEL USAGE - SEE APPENDIX IV - CHANNEL APPLICATION CHART ON PAGE 2.18

This document is available free of charge at
TIMING CHART # 1
www.automaticproducts.com

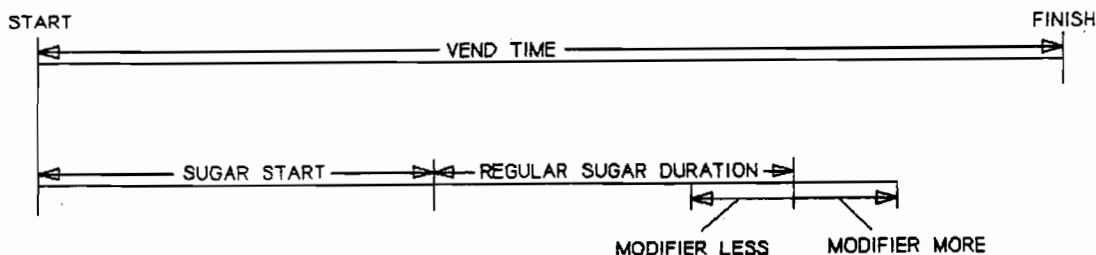

CANISTER RACK INDEX CHART

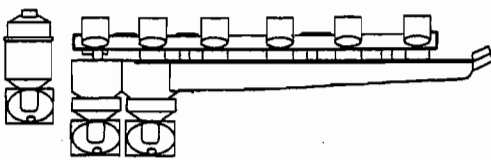
 <p align="center">1 - 1 - 5</p>	<p align="center">1-1-5</p>	<p align="center">RACK CONFIGURATION</p> <p align="center">∅</p> <p align="center">SEE CONFIGURATION CHART, CANISTER RACK LAYOUT, RECIPES AND LABEL ASSIGNMENTS ON PAGE 1.08</p>
--	------------------------------------	---

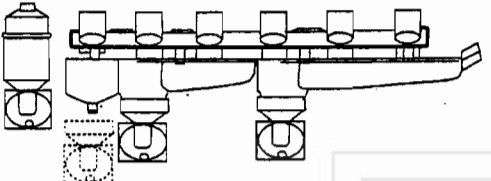
 <p align="center">1 - 1 - 2 - 3</p>	<p align="center">1-1-2-3</p>	<p align="center">RACK CONFIGURATION</p> <p align="center">1</p> <p align="center">SEE CONFIGURATION CHART, CANISTER RACK LAYOUT, RECIPES AND LABEL ASSIGNMENTS ON PAGE 1.14</p>
--	--------------------------------------	---

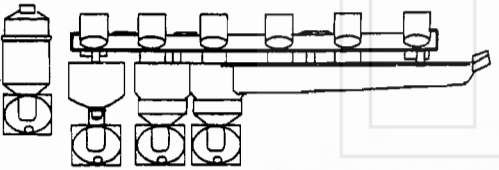
 <p align="center">1 - 1 - 1 - 4</p>	<p align="center">1-1-1-4</p>	<p align="center">RACK CONFIGURATION</p> <p align="center">2</p> <p align="center">SEE CONFIGURATION CHART, CANISTER RACK LAYOUT, RECIPES AND LABEL ASSIGNMENTS ON PAGE 1.25</p>
--	--------------------------------------	---

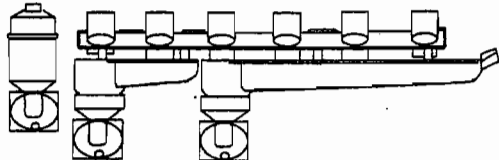
 <p align="center">1 - 2 - 4</p>	<p align="center">1-2-4</p>	<p align="center">RACK CONFIGURATION</p> <p align="center">A</p> <p align="center">SEE CONFIGURATION CHART, CANISTER RACK LAYOUT, RECIPES AND LABEL ASSIGNMENTS ON PAGE 1.20</p>
--	------------------------------------	---



RACK CONFIGURATION Ø

MODE 11 OPTIONS

0	FLASHING Y		FLASHING N	
OPT 1 Y/N	Brewed regular coffee - RECIPE Ø1B & Ø3B		No brewer - FD coffee - RECIPE Ø1F & Ø3F	
OPT 2 Y/N	Brewed decaf coffee - RECIPE Ø2B *		No brewer - FD decaf - RECIPE Ø2F	
IF OPT 3 IS → AND OPT 4 IS →	FLASHING Y	FLASHING Y	FLASHING N	FLASHING N
	FLASHING Y	FLASHING N	FLASHING Y	FLASHING N
THEN SELECTION 4 IS	FRESH BREW CSC WITH CREME & SUGAR	FREEZE DRIED CSC WITH CREME & SUGAR	SGC WITHOUT CREME & SUGAR	FDG AUGER WITH CREME & SUGAR
USE RECIPE #	RECIPE Ø4B	RECIPE Ø4F	NOT AVAILABLE	RECIPE Ø4
OPT 5 Y/N	ONE CUP SIZE - will dispense from small cabinet first		TWO CUP SIZES	
OPT 6 Y/N	Will vend large cup to deliver small drink if out of small cups		Small drink disabled if out of small cups, will display "USE OTHER CUP SIZE"	
OPT 7 Y/N	Will substitute small drink for large drink if out of large cups unless exact change is needed		No substitution if out of large cups, will display "USE OTHER CUP SIZE"	

* OPTION 1 MUST BE YES TO HAVE FRESH BREWED DECAF

SELECTOR PANEL LAYOUT

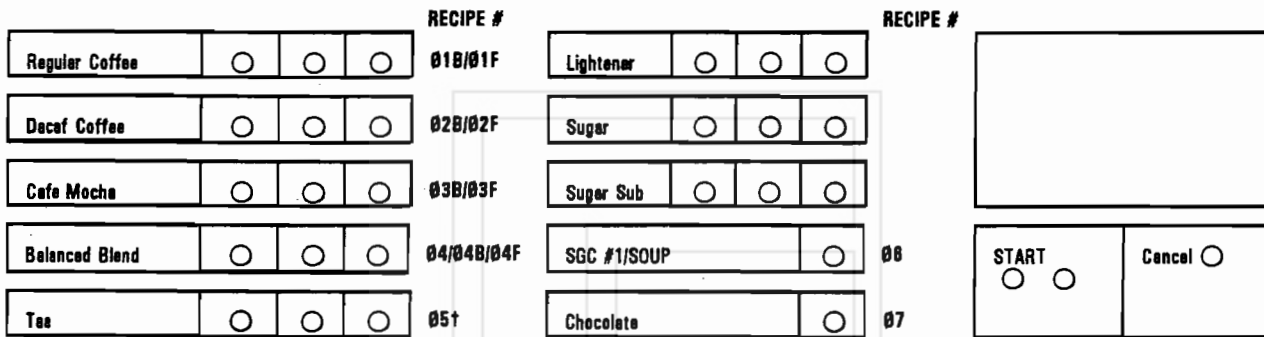

† FB & FD TEA USE THE SAME CHANNELS - SEE RECIPES

RACK LAYOUT ØØC 1-1-5

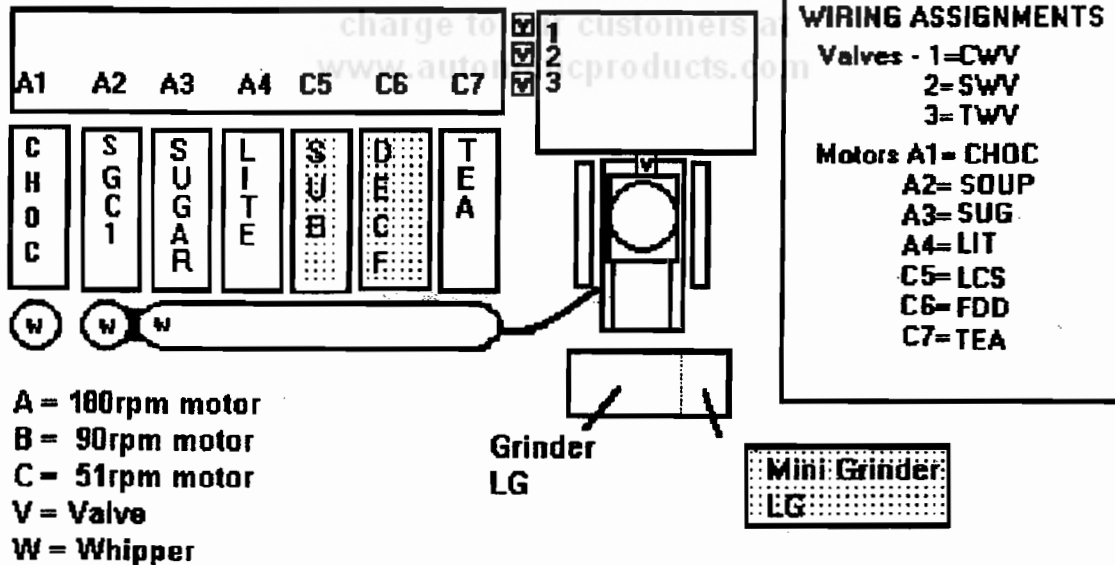

**RECIPE LIST FOR MODEL 213
VERSION 00C
STANDARD CANISTER RACK**



SELECTION #1 FRESH BREW REGULAR COFFEE - 12 oz. REGULAR				
RECIPE #1B				
CHANNEL	FUNCTION	START	DURATION	MODIFIER
05	LARGE GRINDER - SELECTION 1	0.3	1.30	.25
06	LG REGULAR COFFEE - SELECTION 1	0.1	2.50	.25
07	COFFEE BREWER CYCLE	4.0	25.00	
08	BREW WATER - SELECTION 1	5.1	5.80	
09	BREWER FILL DELAY	7.4	3.60	
10	PRESSURE RELIEF DELAY	19.0	2.50	
11	MAKE-UP WATER - SELECTION 1	13.1	0.00	
12	COFFEE LIGHTENER - SELECTION 1	12.0	1.05	.30
13	COFFEE SUGAR - SELECTION 1	12.5	1.60	.30
14	COFFEE SUGAR SUB - SELECTION 1	12.5	1.40	.25
15	WHIPPER-TROUGH - SELECTION 1	11.3	0.0	

SELECTION #1 FREEZE DRIED REGULAR COFFEE - 12 oz. REGULAR				
RECIPE #1F				
CHANNEL	FUNCTION	START	DURATION	MODIFIER
06	FD REGULAR COFFEE - SELECTION 1	2.8	3.70	.25
11	FD COFFEE WATER - SELECTION 1	0.8	10.60	
12	COFFEE LIGHTENER - SELECTION 1	2.2	1.05	.30
13	COFFEE SUGAR - SELECTION 1	3.8	1.60	.30
14	COFFEE SUGAR SUB - SELECTION 1	3.8	1.40	.25
15	WHIPPER-TROUGH - SELECTION 1	1.9	0.0	

FOR ADDITIONAL INFORMATION ON CHANNEL USAGE - SEE APPENDIX IV - CHANNEL APPLICATION CHART



SELECTION #2 FRESH BREW DECAF COFFEE - 12 oz.				
RECIPE #2B				
CHANNEL	FUNCTION	START	DURATION	MODIFIER
07	COFFEE BREWER CYCLE	4.0	25.00	
09	BREWER FILL DELAY	7.4	3.60	
10	PRESSURE RELIEF DELAY	19.0	2.50	
16	LARGE GRINDER - SELECTION 2#	0.3	0.00	.25
17	LG COFFEE AUGER - SELECTION 2#	1.20	0.00	.25
18	DECAF (LG/MINI GRINDER) - SELECTION 2	0.2	1.60	.25
19	BREW WATER - SELECTION 2	5.1	5.80	
20	MAKE UP WATER - SELECTION 2	13.0	0.00	
21	COFFEE LIGHTENER - SELECTION 2	12.0	1.05	.30
22	COFFEE SUGAR - SELECTION 2	12.5	1.60	.30
23	COFFEE SUGAR SUB - SELECTION 2	12.5	1.40	.25
24	WHIPPER-TROUGH - SELECTION 2	11.3	0.0	

ONLY ONE OF THESE CHANNELS MAY BE USED AT A TIME

SELECTION #2 FREEZE DRIED DECAF COFFEE - 12 oz.				
RECIPE #2F				
CHANNEL	FUNCTION	START	DURATION	MODIFIER
17	FD COFFEE - SELECTION 2	0.0	0.00	.25
18	FD DECAF - SELECTION 2	2.8	3.60	.25
20	FD WATER - SELECTION 2	0.8	10.60	
21	COFFEE LIGHTENER - SELECTION 2	2.2	1.05	.30
22	COFFEE SUGAR - SELECTION 2	3.8	1.60	.30
23	COFFEE SUGAR SUB - SELECTION 2	3.8	1.40	.25
24	WHIPPER-TROUGH - SELECTION 2	1.9	00.0	



INDICATES CHANNELS NOT NORMALLY USED IN THIS SELECTION

FOR ADDITIONAL INFORMATION ON CHANNEL USAGE - SEE APPENDIX IV - CHANNEL APPLICATION CHART

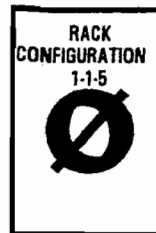

SELECTION #3 CUSTOM SELECT COFFEE - 12 oz. CAFE MOCHA				
RECIPE 03B				
CHANNEL	FUNCTION	START	DURATION	MODIFIER
07	BREW MOTOR CYCLE	4.0	25.00	
09	BREWER FILL DELAY	7.4	3.60	
10	PRESSURE RELIEF DELAY	19.0	2.50	
25	LARGE GRINDER - SELECTION 3	0.3	1.00	.25
26	LG COFFEE - SELECTION 3	1.4	1.75	.25
27	DECAF (LG OR SMALL GRINDER) - SELECTION 3	0.2	0.00	.25
28	BREW WATER - SELECTION 3	5.1	4.00	
29	MAKE-UP WATER - SELECTION 3	12.3	0.00	
30	COFFEE LIGHTENER - SELECTION 3	10.6	0.60	.15
31	COFFEE SUGAR - SELECTION 3	10.9	1.12	.15
32	COFFEE SUGAR SUB - SELECTION 3	10.9	1.10	.15
33	WHIPPER-TROUGH - SELECTION 3	9.6	8.00	
34	CHOCOLATE AUGER - SELECTION 3	16.0	2.30	
35	CHOCOLATE WATER & WHIPPER - SELECTION 3	15.0	3.55	

SELECTION #3 FREEZE DRIED CUSTOM SELECT COFFEE - 12 oz. CAFE MOCHA				
RECIPE 03F				
CHANNEL	FUNCTION	START	DURATION	MODIFIER
26	FD COFFEE - SELECTION 3	2.8	2.20	.25
27	FD DECAF - SELECTION 3	0.0	0.00	.25
29	FD WATER - SELECTION 3	0.8	6.80	
30	COFFEE LIGHTENER - SELECTION 3	2.2	0.60	.15
31	COFFEE SUGAR - SELECTION 3	3.3	1.12	.15
32	COFFEE SUGAR SUB - SELECTION 3	3.3	1.10	.15
33	WHIPPER-TROUGH - SELECTION 3	1.9	8.00	
34	CHOCOLATE AUGER - SELECTION 3	11.0	2.30	
35	CHOCOLATE WATER & WHIPPER - SELECTION 3	10.0	3.55	



INDICATES CHANNELS NOT NORMALLY USED IN THIS SELECTION

FOR ADDITIONAL INFORMATION ON CHANNEL USAGE - SEE APPENDIX IV - CHANNEL APPLICATION CHART



SELECTION #4 FB CSC - 12 oz. BALANCED BLEND - BLEND OF REGULAR AND DECAF				
RECIPE 04B				
CHANNEL	FUNCTION	START	DURATION	MODIFIER
07	BREW MOTOR CYCLE	4.0	25.00	
09	BREWER FILL DELAY	7.4	3.60	
10	PRESSURE RELIEF DELAY	19.0	2.50	
38	LARGE GRINDER - SELECTION 4/CSC	0.3	1.00	.25
39	LG COFFEE - SELECTION 4/CSC	1.4	1.25	.25
40	DECAF (LG/SMALL GRINDER) - SELECTION 4/CSC	0.2	1.00	.25
42	BREW WATER - SELECTION 4/CSC	5.1	5.30	
43	MAKE-UP WATER - SELECTION 4/CSC	13.0	0.00	
44	COFFEE LIGHTENER - SELECTION 4/CSC	12.0	1.05	.30
45	COFFEE SUGAR - SELECTION 4/CSC	12.5	1.60	.30
46	COFFEE SUGAR SUB - SELECTION 4/CSC	12.5	1.40	.25
47	WHIPPER-TROUGH - SELECTION 4/CSC	11.3	0.00	
52	SGE #1 AUGER - SELECTION 4/CSC	15.0	0.00	
53	SGE #1 WATER/WHIPPER - SELECTION 4/CSC	15.0	0.00	

SELECTION #4 FD CSC - 12 oz. BALANCED BLEND - BLEND OF REGULAR AND DECAF				
RECIPE 04F				
CHANNEL	FUNCTION	START	DURATION	MODIFIER
39	FD COFFEE - SELECTION 4/CSC	5.0	1.80	.25
40	FD DECAF - SELECTION 4/CSC	2.3	1.80	.25
43	FD WATER - SELECTION 4/CSC	0.8	10.60	
44	COFFEE LIGHTENER - SELECTION 4/CSC	2.5	1.05	.30
45	COFFEE SUGAR - SELECTION 4/CSC	3.5	1.60	.30
46	COFFEE SUGAR SUB - SELECTION 4/CSC	3.5	1.40	.25
47	WHIPPER-TROUGH - SELECTION 4/CSC	1.9	0.00	
52	SGE #1 - SELECTION 4/CSC	15.0	0.00	
53	SGE #1 WATER & WHIPPER - SELECTION 4/CSC	15.0	0.00	



INDICATES CHANNELS NOT NORMALLY USED IN THIS SELECTION

FOR ADDITIONAL INFORMATION ON CHANNEL USAGE - SEE APPENDIX IV - CHANNEL APPLICATION CHART



SELECTION #4 FD GOURMET - 12 oz. SOLUBLE				
RECIPE #4				
CHANNEL	FUNCTION	START	DURATION	MODIFIER
41	FD DECAF - SELECTION 4/CSC	2.8	1.80	.25
43	FD WATER - SELECTION 4/CSC	0.8	10.60	
44	COFFEE LIGHTENER - SELECTION 4/CSC	2.2	1.05	.30
45	COFFEE SUGAR - SELECTION 4/CSC	3.8	1.60	.30
46	COFFEE SUGAR SUB - SELECTION 4/CSC	3.8	1.40	.25
47	WHIPPER-TROUGH - SELECTION 4/CSC	1.9	0.00	
52	SGC #1 - SELECTION 4/CSC	15.0	0.00	
53	SGC #3 WATER & WHIPPER - SELECTION 4/CSC	15.0	0.00	

SELECTION #5 - 12 oz. FD TEA				
RECIPE #5				
CHANNEL	FUNCTION	START	DURATION	MODIFIER
54	TEA AUGER	2.8	2.47	0.15
55	WATER - FD TEA	0.8	10.60	
56	FB TEA WATER	0.5	0.00	
57	FB TEA BREWER CYCLE	22.0	0.00	
58	TEA WHITENER AUGER	2.2	0.50	0.20
59	TEA SUGAR AUGER	3.8	0.70	0.20
60	TEA SUGAR SUBSTITUTE AUGER	3.8	1.00	0.20
61	WHIPPER - TEA	1.9	0.00	

SELECTION #5 - 12 oz. FB TEA				
RECIPE #5				
CHANNEL	FUNCTION	START	DURATION	MODIFIER
54	TEA AUGER	3.0	0.75	0.15
55	FB TEA MAKE UP WATER	4.0	3.00	
56	FB TEA WATER	0.5	10.00	
57	FB TEA BREWER CYCLE	23.0	2.80	
58	TEA WHITENER AUGER	4.5	0.50	0.20
59	TEA SUGAR AUGER	5.8	0.70	0.20
60	TEA SUGAR SUBSTITUTE AUGER	5.8	0.70	0.20
61	WHIPPER - TEA	4.0	0.00	

SELECTION #6 - 12 oz. SOLUBLE GOURMET COFFEE #1/SOUP				
RECIPE #6				
CHANNEL	FUNCTION	START	DURATION	MODIFIER
65	AUGER - SGC #1/SOUP	2.1	6.15	
66	WATER/WHIPPER - SGC #1/SOUP	1.0	10.20	

SELECTION #7 - 12 OZ. WHIPPED HOT CHOCOLATE				
RECIPE #7				
CHANNEL	FUNCTION	START	DURATION	MODIFIER
67	CHDCOLATE AUGER	2.2	6.60	
68	WATER/WHIPPER - CHOCOLATE	1.0	10.50	



INDICATES CHANNELS NOT NORMALLY USED IN THIS SELECTION
FOR ADDITIONAL INFORMATION ON CHANNEL USAGE - SEE APPENDIX IV - CHANNEL APPLICATION CHART

RACK CONFIGURATION 1

MODE 11 OPTIONS

1	FLASHING Y	FLASHING N
OPT 1 Y/N	Brewed regular coffee - RECIPE 11B & 13B	No brewer - FD coffee - RECIPE 11F & 13F
OPT 2 Y/N	Brewed decaf coffee - RECIPE 12B *	No brewer - FD decaf - RECIPE 12F
IF OPT 3 IS → AND OPT 4 IS →	FLASHING Y	FLASHING N
THEN SELECTION 4 IS	FLASHING Y	FLASHING N
USE RECIPE #	FRESH BREW CSC WITH CREME & SUGAR RECIPE 14B	FRESH BREW CSC WITH CREME & SUGAR RECIPE 14F
OPT 5 Y/N	ONE CUP SIZE - will dispense from small cabinet first	TWO CUP SIZES
OPT 6 Y/N	Will vend large cup to deliver small drink if out of small cups	Small drink disabled if out of small cups, will display "USE OTHER CUP SIZE"
OPT 7 Y/N	Will substitute small drink for large drink if out of large cups unless exact change is needed	No substitution if out of large cups, will display "USE OTHER CUP SIZE"

* OPTION 1 MUST BE YES TO HAVE FRESH BREWED DECAF

SELECTOR PANEL LAYOUT

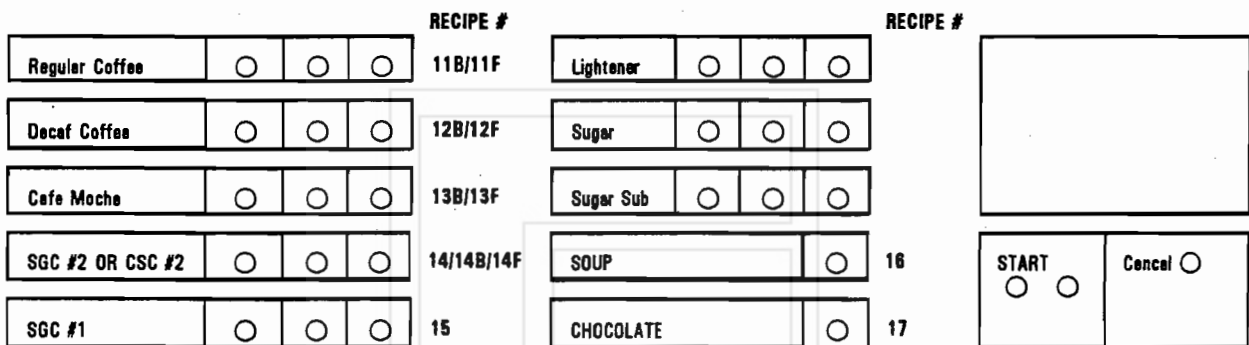

RACK LAYOUT 10C 1-1-2-3

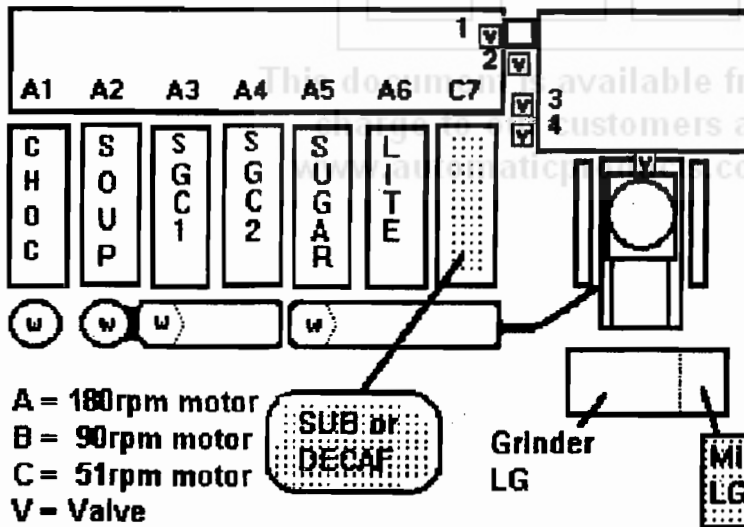

WIRING ASSIGNMENTS

- Valves -**
 - 1= CWV
 - 2= BTWV
 - 3= SWV
 - 4= TWV
- Motors -**
 - A1= CHOC
 - A2= SOUP
 - A3= TEA
 - A4= FDG
 - A5= SUG
 - A6= LIT
 - C7= LCS or FDD

- A = 180rpm motor
- B = 90rpm motor
- C = 51rpm motor
- V = Valve
- W = Whipper

SUB or DECAF

Grinder LG

Mini Grinder LG

RACK CONFIGURATION 1-1-2-3
1

**RECIPE LIST FOR MODEL 213
VERSION 10C
SPLIT TROUGH CANISTER RACK 1-1-2-3**

SELECTION #1 FRESH BREW REGULAR COFFEE - 12 oz. REGULAR				
RECIPE 11B				
CHANNEL	FUNCTION	START	DURATION	MODIFIER
05	LARGE GRINDER - SELECTION 1	0.3	1.30	.25
06	LG REGULAR COFFEE - SELECTION 1	0.2	2.50	.25
07	COFFEE BREWER CYCLE	4.0	25.00	
08	BREW WATER - SELECTION 1	5.1	5.80	
09	BREWER FILL DELAY	7.4	3.60	
10	PRESSURE RELIEF DELAY	19.0	2.50	
11	MAKE-UP WATER - SELECTION 1	12.0	0.00	
12	COFFEE LIGHTENER - SELECTION 1	12.5	1.05	.30
13	COFFEE SUGAR - SELECTION 1	12.5	1.60	.30
14	COFFEE SUGAR SUB - SELECTION 1	12.0	1.40	.30
15	WHIPPER-TROUGH - SELECTION 1	8.6	0.0	

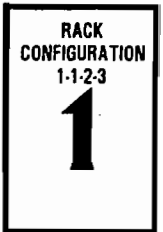

SELECTION #1 FREEZE DRIED REGULAR COFFEE - 12 oz. REGULAR				
RECIPE 11F				
CHANNEL	FUNCTION	START	DURATION	MODIFIER
06	FD REGULAR COFFEE - SELECTION 1	2.8	3.70	.25
11	FD COFFEE WATER - SELECTION 1	0.8	10.60	
12	COFFEE LIGHTENER - SELECTION 1	2.2	1.05	.30
13	COFFEE SUGAR - SELECTION 1	3.8	1.60	.30
14	COFFEE SUGAR SUB - SELECTION 1	3.8	1.40	.30
15	WHIPPER-TROUGH - SELECTION 1	1.9	0.0	

FOR ADDITIONAL INFORMATION ON CHANNEL USAGE - SEE APPENDIX IV - CHANNEL APPLICATION CHART

RACK
CONFIGURATION
1-1-2-3
1

SELECTION #2 FRESH BREW DECAF COFFEE - 12 oz.				
RECIPE 12B				
CHANNEL	FUNCTION	START	DURATION	MODIFIER
07	COFFEE BREWER CYCLE	4.0	25.00	
09	BREWER FILL DELAY	7.4	3.60	
10	PRESSURE RELIEF DELAY	19.0	2.50	
16	LARGE GRINDER - SELECTION 2#	0.3	0.00	.25
17	LG COFFEE AUGER - SELECTION 2#	0.0	0.00	.25
18	DECAF (LG/MINI GRINDER) - SELECTION 2	0.2	1.60	.25
19	BREW WATER - SELECTION 2	5.1	5.80	
20	MAKE UP WATER - SELECTION 2	13.0	0.00	
21	COFFEE LIGHTENER - SELECTION 2	12.0	1.05	.30
22	COFFEE SUGAR - SELECTION 2	12.5	1.60	.30
23	COFFEE SUGAR SUB - SELECTION 2	12.5	1.40	.25
24	WHIPPER-TROUGH - SELECTION 2	11.3	0.0	

ONLY ONE OF THESE CHANNELS MAY BE USED AT A TIME

SELECTION #2 FREEZE DRIED DECAF COFFEE - 12 oz.				
RECIPE 12F				
CHANNEL	FUNCTION	START	DURATION	MODIFIER
17	FD COFFEE - SELECTION 2	0.0	0.00	.25
18	FD DECAF - SELECTION 2	2.8	3.60	.25
20	FD WATER - SELECTION 2	0.8	10.60	
21	COFFEE LIGHTENER - SELECTION 2	2.2	1.05	.30
22	COFFEE SUGAR - SELECTION 2	3.8	1.60	.30
23	COFFEE SUGAR SUB - SELECTION 2	3.8	1.40	.25
24	WHIPPER-TROUGH - SELECTION 2	1.9	0.0	

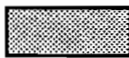

INDICATES CHANNELS NOT NORMALLY USED IN THIS SELECTION

FOR ADDITIONAL INFORMATION ON CHANNEL USAGE - SEE APPENDIX IV - CHANNEL APPLICATION CHART

SELECTION #3 CUSTOM SELECT COFFEE - 12 oz. CAFE MOCHA

RECIPE 13B

CHANNEL	FUNCTION	START	DURATION	MODIFIER
07	BREW MOTOR CYCLE	4.0	25.00	
09	BREWER FILL DELAY	7.4	3.60	
10	PRESSURE RELIEF DELAY	19.0	2.50	
25	LARGE GRINDER - SELECTION 3	0.3	1.00	.25
26	LG COFFEE - SELECTION 3	0.1	1.75	.25
27	DECAF (LG OR SMALL GRINDER) - SELECTION 3	0.2	0.00	.25
28	BREW WATER - SELECTION 3	5.1	4.00	
29	MAKE-UP WATER - SELECTION 3	12.3	0.00	
30	COFFEE LIGHTENER - SELECTION 3	10.6	0.65	.15
31	COFFEE SUGAR - SELECTION 3	11.0	1.10	.15
32	COFFEE SUGAR SUB - SELECTION 3	11.0	1.00	.15
33	WHIPPER-TROUGH - SELECTION 3	9.6	8.00	
34	CHOCOLATE AUGER - SELECTION 3	16.0	2.30	
35	CHOCOLATE WATER & WHIPPER - SELECTION 3	15.0	3.55	

RACK
CONFIGURATION
1-1-2-3
1

SELECTION #3 FREEZE DRIED CUSTOM SELECT COFFEE - 12 oz. CAFE MOCHA

RECIPE 13F

CHANNEL	FUNCTION	START	DURATION	MODIFIER
26	FD COFFEE - SELECTION 3	2.8	2.20	.25
27	FD DECAF - SELECTION 3	0.0	0.00	.25
29	FD WATER - SELECTION 3	0.8	6.80	
30	COFFEE LIGHTENER - SELECTION 3	2.2	0.65	.15
31	COFFEE SUGAR - SELECTION 3	3.3	1.12	.15
32	COFFEE SUGAR SUB - SELECTION 3	3.3	1.10	.15
33	WHIPPER-TROUGH - SELECTION 3	1.9	6.80	
34	CHOCOLATE AUGER - SELECTION 3	11.0	2.30	
35	CHOCOLATE WATER & WHIPPER - SELECTION 3	10.0	3.55	

 INDICATES CHANNELS NOT NORMALLY USED IN THIS SELECTION

FOR ADDITIONAL INFORMATION ON CHANNEL USAGE - SEE APPENDIX IV - CHANNEL APPLICATION CHART

RACK
CONFIGURATION
1-1-2-3
1

SELECTION #4 FB CSC - 12 oz. BALANCED BLEND - BLEND OF REGULAR AND DECAF				
RECIPE 14B				
CHANNEL	FUNCTION	START	DURATION	MODIFIER
07	BREW MOTOR CYCLE	4.0	25.00	
09	BREWER FILL DELAY	7.4	3.60	
10	PRESSURE RELIEF DELAY	19.0	2.50	
38	LARGE GRINDER - SELECTION 4/CSC	0.3	1.00	.25
39	COFFEE AUGER - SELECTION 4/CSC	1.4	1.25	.25
40	DECAF (LG/SMALL GRINDER) - SELECTION 4/CSC	0.2	1.00	.25
42	BREW WATER - SELECTION 4/CSC	5.1	5.30	
43	MAKE-UP WATER - SELECTION 4/CSC	13.0	0.00	
44	COFFEE LIGHTENER - SELECTION 4/CSC	12.0	1.05	.30
45	COFFEE SUGAR - SELECTION 4/CSC	12.5	1.60	.30
46	COFFEE SUGAR SUB - SELECTION 4/CSC	12.5	1.40	.25
47	WHIPPER-TROUGH - SELECTION 4/CSC	11.3	0.00	
52	SGC #1 AUGER - SELECTION 4/CSC	16.0	0.00	
53	SGC #1 WATER & WHIPPER - SELECTION 4/CSC	15.0	0.00	

SELECTION #4 FD CSC - 12 oz. BALANCED BLEND - BLEND OF REGULAR AND DECAF				
RECIPE 14F				
CHANNEL	FUNCTION	START	DURATION	MODIFIER
39	COFFEE AUGER - SELECTION 4/CSC	5.0	1.80	.25
40	DECAF - SELECTION 4/CSC	2.3	1.80	.25
43	FD WATER - SELECTION 4/CSC	0.8	10.60	
44	COFFEE LIGHTENER - SELECTION 4/CSC	2.2	1.05	.30
45	COFFEE SUGAR - SELECTION 4/CSC	3.8	1.60	.30
46	COFFEE SUGAR SUR - SELECTION 4/CSC	3.8	1.40	.25
47	WHIPPER-TROUGH - SELECTION 4/CSC	1.9	0.00	
52	SGC #1 - SELECTION 4/CSC	16.0	0.00	
53	SGC #1 WATER & WHIPPER - SELECTION 4/CSC	15.0	0.00	

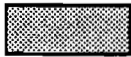

INDICATES CHANNELS NOT NORMALLY USED IN THIS SELECTION

FOR ADDITIONAL INFORMATION ON CHANNEL USAGE - SEE APPENDIX IV - CHANNEL APPLICATION CHART

SELECTION #4 SGC #2 - 12 oz. SOLUBLE GOURMET COFFEE				
RECIPE 14				
CHANNEL	FUNCTION	START	DURATION	MODIFIER
41	SGC #2 AUGER - SELECTION 4	2.0	6.10	.00
48	SGC #2 WATER - SELECTION 4	1.0	10.20	
49	SGC #2 WHIPPER - SELECTION 4	1.0	10.20	

SELECTION #5 SGC #1 - 12 oz. SOLUBLE GOURMET COFFEE				
RECIPE 15				
CHANNEL	FUNCTION	START	DURATION	MODIFIER
54	AUGER SGC #1 - SELECTION 5	2.1	6.20	0.00
62	WHIPPER SGC #1 - SELECTION 5	1.0	10.20	
63	WATER SGC #1 - SELECTION 5	1.0	10.20	

SELECTION #6 - 12 oz. SOUP				
RECIPE 16				
CHANNEL	FUNCTION	START	DURATION	MODIFIER
65	AUGER - SOUP	2.1	2.50	
66	WATER/WHIPPER - SOUP	1.0	10.60	

SELECTION #7 - 12 OZ. WHIPPED HOT CHOCOLATE				
RECIPE 17				
CHANNEL	FUNCTION	START	DURATION	MODIFIER
67	CHOCOLATE AUGER	2.2	6.50	
68	WATER/WHIPPER - CHOCOLATE	1.0	10.50	

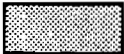

INDICATES CHANNELS NOT NORMALLY USED IN THIS SELECTION

FOR ADDITIONAL INFORMATION ON CHANNEL USAGE - SEE APPENDIX IV - CHANNEL APPLICATION CHART

RACK
CONFIGURATION
1-1-2-3
1

RACK CONFIGURATION A

MODE 11 OPTIONS

A	FLASHING Y	FLASHING N
OPT 1 Y/N	Brewed regular coffee - RECIPE A1B & A3B	No brewer - FD coffee - RECIPE A1F & A3F
OPT 2 Y/N	Brewed decaf coffee - RECIPE A2B *	No brewer - FD decaf - RECIPE A2F
IF OPT 3 IS → AND OPT 4 IS →	FLASHING Y	FLASHING N
THEN SELECTION 4 IS	FRESH BREW CSC WITH CREME & SUGAR	FREEZE DRIED CSC WITH CREME & SUGAR
USE RECIPE #	RECIPE 04B	RECIPE 04F
OPT 5 Y/N	ONE CUP SIZE - will dispense from small cabinet first	TWO CUP SIZES
OPT 6 Y/N	Will vend large cup to deliver small drink if out of small cups	Small drink disabled if out of small cups, will display "USE OTHER CUP SIZE"
OPT 7 Y/N	Will substitute small drink for large drink if out of large cups unless exact change is needed	No substitution if out of large cups, will display "USE OTHER CUP SIZE"

* OPTION 1 MUST BE YES TO HAVE FRESH BREWED DECAF

SELECTOR PANEL LAYOUT

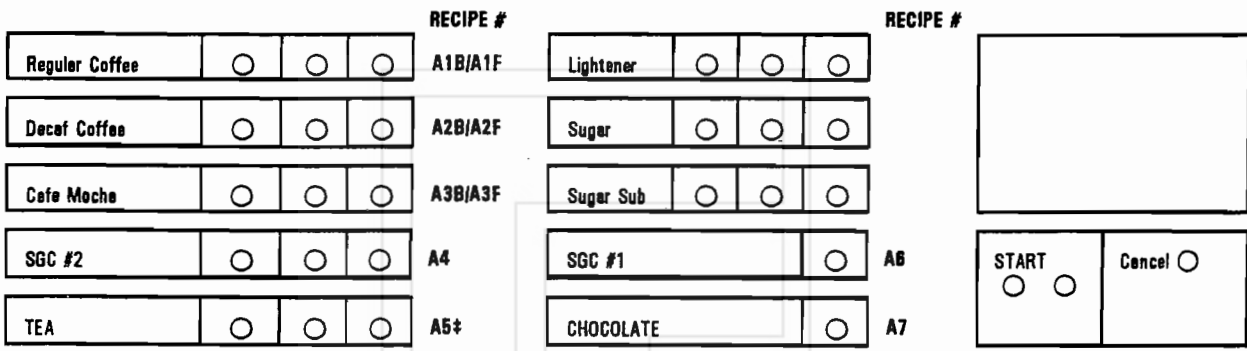

± FB & FD TEA USE SAME CHANNELS - SEE RECIPE TABLE

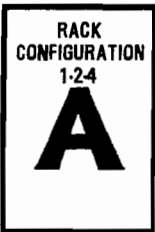

RACK LAYOUT A0C 1-2-4

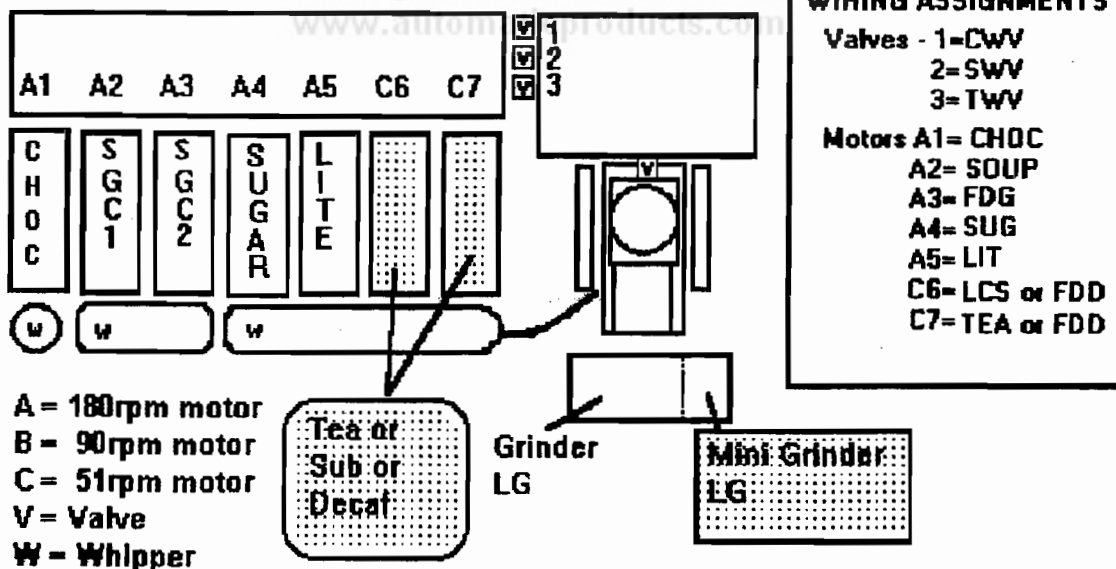

**RECIPE LIST FOR MODEL 213
VERSION AOC
SPLIT TROUGH CANISTER RACK 1-2-4**

SELECTION #1 FRESH BREW REGULAR COFFEE - 12 oz. REGULAR				
RECIPE A1B				
CHANNEL	FUNCTION	START	DURATION	MODIFIER
05	LARGE GRINDER - SELECTION 1	0.3	1.30	.25
06	LG REGULAR COFFEE - SELECTION 1	0.1	2.50	.25
07	COFFEE BREWER CYCLE	4.0	25.00	
08	BREW WATER - SELECTION 1	5.1	5.80	
09	BREWER FILL DELAY	7.4	3.60	
10	PRESSURE RELIEF DELAY	19.0	2.50	
11	MAKE-UP WATER - SELECTION 1	13.1	0.00	
12	COFFEE LIGHTENER - SELECTION 1	12.0	1.05	.30
13	COFFEE SUGAR - SELECTION 1	12.5	1.60	.30
14	COFFEE SUGAR SUB - SELECTION 1	12.5	1.40	.25
15	WHIPPER-TROUGH - SELECTION 1	8.6	0.0	

SELECTION #1 FREEZE DRIED REGULAR COFFEE - 12 oz. REGULAR				
RECIPE A1F				
CHANNEL	FUNCTION	START	DURATION	MODIFIER
06	FD REGULAR COFFEE - SELECTION 1	2.8	3.70	.25
11	FD COFFEE WATER - SELECTION 1	0.8	10.60	
12	COFFEE LIGHTENER - SELECTION 1	2.2	1.05	.30
13	COFFEE SUGAR - SELECTION 1	3.8	1.60	.30
14	COFFEE SUGAR SUB - SELECTION 1	3.8	1.40	.25
15	WHIPPER-TROUGH - SELECTION 1	1.9	0.0	

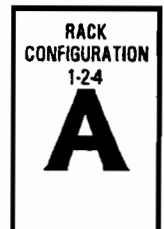

FOR ADDITIONAL INFORMATION ON CHANNEL USAGE - SEE APPENDIX IV - CHANNEL APPLICATION CHART

SELECTION #2 FRESH BREW DECAF COFFEE - 12 oz.

RECIPE A2B

CHANNEL	FUNCTION	START	DURATION	MODIFIER
07	COFFEE BREWER CYCLE	4.0	25.00	
09	BREWER FILL DELAY	7.4	3.60	
10	PRESSURE RELIEF DELAY	19.0	2.50	
16	LARGE GRINDER - SELECTION 2#	0.0	0.00	.25
17	LG COFFEE AUGER - SELECTION 2#	0.0	0.00	.25
18	DECAF (LG/MINI GRINDER) - SELECTION 2	0.2	1.60	.25
19	BREW WATER - SELECTION 2	5.1	5.80	
20	MAKE UP WATER - SELECTION 2	13.0	0.00	
21	COFFEE LIGHTENER - SELECTION 2	12.0	1.05	.30
22	COFFEE SUGAR - SELECTION 2	12.5	1.60	.30
23	COFFEE SUGAR SUB - SELECTION 2	12.5	1.40	.25
24	WHIPPER-TROUGH - SELECTION 2	11.3	0.0	

ONLY ONE OF THESE CHANNELS MAY BE USED AT A TIME

SELECTION #2 FREEZE DRIED DECAF COFFEE - 12 oz.

RECIPE A2F

CHANNEL	FUNCTION	START	DURATION	MODIFIER
17	FD COFFEE - SELECTION 2	0.7	0.00	.25
18	FD DECAF - SELECTION 2	2.8	3.60	.25
20	FD WATER - SELECTION 2	0.8	10.60	
21	COFFEE LIGHTENER - SELECTION 2	2.2	1.05	.30
22	COFFEE SUGAR - SELECTION 2	3.8	1.60	.30
23	COFFEE SUGAR SUB - SELECTION 2	3.8	1.05	.25
24	WHIPPER-TROUGH - SELECTION 2	1.9	0.0	



INDICATES CHANNELS NOT NORMALLY USED IN THIS SELECTION

FOR ADDITIONAL INFORMATION ON CHANNEL USAGE - SEE APPENDIX IV - CHANNEL APPLICATION CHART



SELECTION #3 CUSTOM SELECT COFFEE - 12 oz. CAFE MOCHA				
RECIPE A3B				
CHANNEL	FUNCTION	START	DURATION	MODIFIER
07	BREW MOTOR CYCLE	4.0	25.00	
09	BREWER FILL DELAY	7.4	3.60	
10	PRESSURE RELIEF DELAY	19.0	2.50	
25	LARGE GRINDER - SELECTION 3	0.3	1.00	.25
26	LG COFFEE - SELECTION 3	0.1	1.75	.25
27	DECAF (LG OR SMALL GRINDER) - SELECTION 3	0.2	0.00	.25
28	BREW WATER - SELECTION 3	5.1	4.00	
29	MAKE-UP WATER - SELECTION 3	12.3	0.00	
30	COFFEE LIGHTENER - SELECTION 3	10.6	0.65	.15
31	COFFEE SUGAR - SELECTION 3	10.9	1.12	.15
32	COFFEE SUGAR SUB - SELECTION 3	10.9	1.10	.15
33	WHIPPER-TROUGH - SELECTION 3	9.6	8.00	
34	CHOCOLATE AUGER - SELECTION 3	16.0	2.30	
35	CHOCOLATE WATER & WHIPPER - SELECTION 3	15.0	3.55	

SELECTION #3 FREEZE DRIED CUSTOM SELECT COFFEE - 12 oz. CAFE MOCHA				
RECIPE A3F				
CHANNEL	FUNCTION	START	DURATION	MODIFIER
26	FD COFFEE - SELECTION 3	2.8	2.20	.25
27	FD DECAF - SELECTION 3	5.8	0.00	.25
29	FD WATER - SELECTION 3	0.8	6.80	
30	COFFEE LIGHTENER - SELECTION 3	2.2	0.65	.15
31	COFFEE SUGAR - SELECTION 3	3.3	1.12	.15
32	COFFEE SUGAR SUB - SELECTION 3	3.3	1.10	.15
33	WHIPPER-TROUGH - SELECTION 3	1.9	8.00	
34	CHOCOLATE AUGER - SELECTION 3	11.0	2.20	
35	CHOCOLATE WATER & WHIPPER - SELECTION 3	10.0	3.50	

SELECTION #4 SGC #2 - 12 oz. SOLUBLE GOURMET COFFEE				
RECIPE A4				
CHANNEL	FUNCTION	START	DURATION	MODIFIER
41	SGC #2 AUGER - SELECTION 4	2.0	6.15	.00
53	SGC #2 WATER & WHIPPER - SELECTION 4	1.0	10.20	



INDICATES CHANNELS NOT NORMALLY USED IN THIS SELECTION

FOR ADDITIONAL INFORMATION ON CHANNEL USAGE - SEE APPENDIX IV - CHANNEL APPLICATION CHART

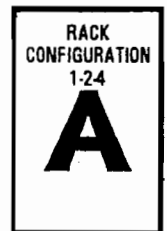

SELECTION #5 - 12 oz. FD TEA				
RECIPE 05				
CHANNEL	FUNCTION	START	DURATION	MODIFIER
54	TEA AUGER	2.8	2.47	0.15
55	WATER - FD TEA	0.8	10.60	
56	FB TEA WATER	0.5	0.00	
57	FB TEA BREWER CYCLE	23.0	0.00	
58	TEA WHITENER AUGER	2.2	0.50	0.20
59	TEA SUGAR AUGER	3.8	0.70	0.20
60	TEA SUGAR SUBSTITUTE AUGER	3.8	1.00	0.20
61	WHIPPER - TEA	1.9	0.00	

SELECTION #5 - 12 oz. FB TEA				
RECIPE 05				
CHANNEL	FUNCTION	START	DURATION	MODIFIER
54	TEA AUGER	3.0	0.75	0.15
55	FB TEA MAKE UP WATER	4.0	3.00	
56	FB TEA WATER	0.5	10.00	
57	FB TEA BREWER CYCLE	23.0	2.80	
58	TEA WHITENER AUGER	4.5	0.50	0.20
59	TEA SUGAR AUGER	5.8	0.70	0.20
60	TEA SUGAR SUBSTITUTE AUGER	5.8	0.70	0.20
61	WHIPPER - TEA	1.9	0.00	

SELECTION #6 - 12 oz. SOLUBLE GOURMET COFFEE #1				
RECIPE A6				
CHANNEL	FUNCTION	START	DURATION	MODIFIER
65	AUGER - SGC #1	2.1	6.15	
66	WATER/WHIPPER - SGC #1	1.0	10.20	

SELECTION #7 - 12 OZ. WHIPPED HOT CHOCOLATE				
RECIPE A7				
CHANNEL	FUNCTION	START	DURATION	MODIFIER
67	CHOCOLATE AUGER	2.1	6.60	
68	WATER/WHIPPER - CHOCOLATE	1.0	10.50	



INDICATES CHANNELS NOT NORMALLY USED IN THIS SELECTION

FOR ADDITIONAL INFORMATION ON CHANNEL USAGE - SEE APPENDIX IV - CHANNEL APPLICATION CHART

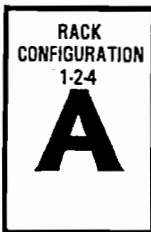

RACK CONFIGURATION 2

MODE 11 OPTIONS

SETTINGS =	FLASHING Y	FLASHING N		
OPT 1 Y/N	Brewed regular coffee - RECIPE 21B & 23B	No brewer - FD coffee - RECIPE 21F & 23F		
OPT 2 Y/N	Brewed decaf coffee - RECIPE 22B *	No brewer - FD decaf - RECIPE 22F		
IF OPT 3 IS AND OPT 4 IS	FLASHING Y	FLASHING Y	FLASHING N	FLASHING N
	FLASHING Y	FLASHING N	FLASHING Y	FLASHING N
THEN SELECTION 4 IS	FRESH BREW CSC WITH CREME & SUGAR	FREEZE DRIED CSC WITH CREME & SUGAR	SGC WITHOUT CREME & SUGAR	FDG AUGER WITH CREME & SUGAR
USE RECIPE #	RECIPE 24B	RECIPE 24F	RECIPE A4	NOT AVAILABLE
OPT 5 Y/N	ONE CUP SIZE - will dispense from small cabinet first	TWO CUP SIZES		
OPT 6 Y/N	Will vend large cup to deliver small drink if out of small cups	Small drink disabled if out of small cups, will display "USE OTHER CUP SIZE"		
OPT 7 Y/N	Will substitute small drink for large drink if out of large cups unless exact change is needed	No substitution if out of large cups, will display "USE OTHER CUP SIZE"		

* OPTION 1 MUST BE YES TO HAVE FRESH BREWED DECAF

SELECTOR PANEL LAYOUT

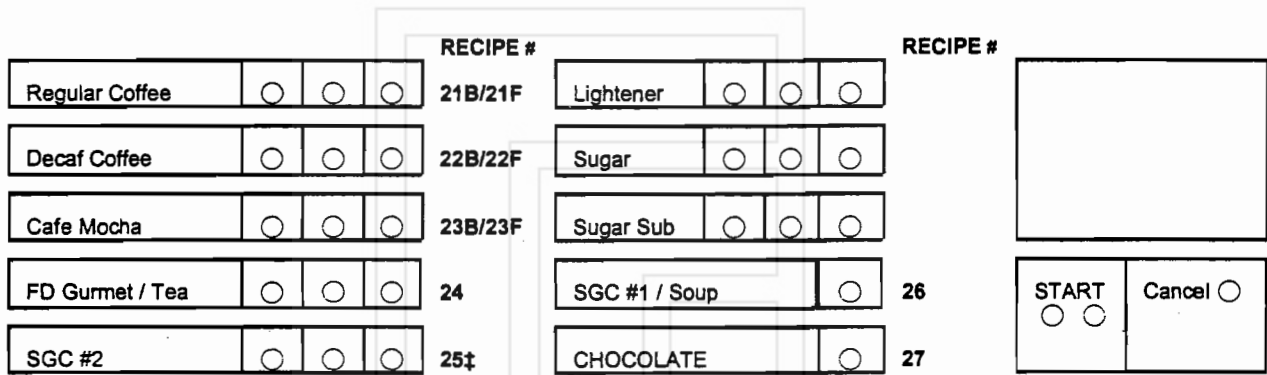

‡ FB & FD TEA USE SAME CHANNELS SEE RECIPE TABLE

RACK LAYOUT 20C 1-1-1-4

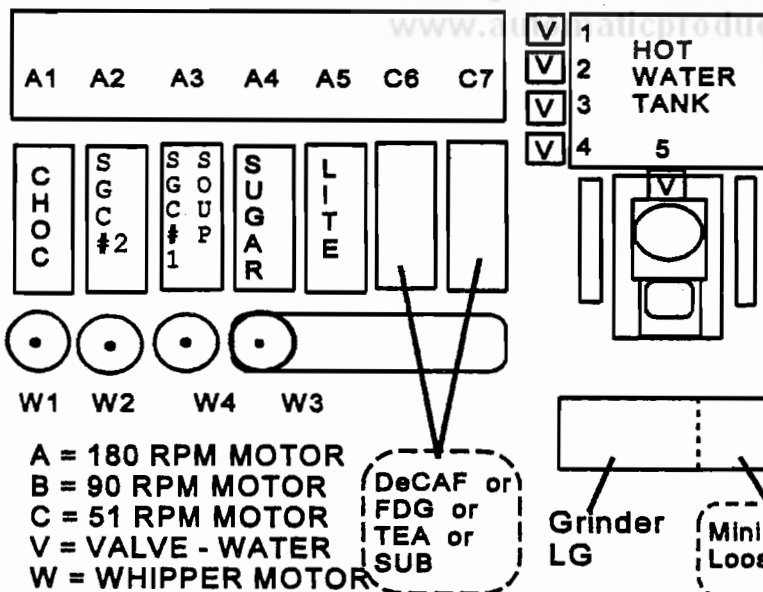

WIRING ASSIGNMENTS

- Valves:**
- 1- CWS
 - 2- BTWV
 - 3- SOUP
 - 4- TWV
 - 5- BCV
- Motors:**
- A1 = CHOC
 - A2 = TEA
 - A3 = SOUP
 - A4 = SUG
 - A5 = LIT
 - C6 = LCS or FDD or FDG
 - C7 = LCS or FDD or FDG



**RECIPE LIST FOR MODEL 213
VERSION 20C OR 25C
SPLIT TROUGH CANISTER RACK 1-1-1-~~1~~**

SELECTION #1 FRESH BREW REGULAR COFFEE - 12 oz. REGULAR				
RECIPE 21B				
CHANNEL	FUNCTION	START	DURATION	MODIFIER
05	LARGE GRINDER - SELECTION 1	0.0	1.30	.25
06	LG REGULAR COFFEE - SELECTION 1	0.0	2.50	.25
07	COFFEE BREWER CYCLE	4.0	25.00	
08	BREW WATER - SELECTION 1	5.1	5.80	
09	BREWER FILL DELAY	7.4	3.60	
10	PRESSURE RELIEF DELAY	19.0	2.50	
11	MAKE-UP WATER - SELECTION 1	13.1	0.00	
12	COFFEE LIGHTENER - SELECTION 1	12.0	1.05	.30
13	COFFEE SUGAR - SELECTION 1	12.5	1.60	.30
14	COFFEE SUGAR SUB - SELECTION 1	12.5	1.40	.25
15	WHIPPER-TROUGH - SELECTION 1	8.6	0.0	

SELECTION #1 FREEZE DRIED REGULAR COFFEE - 12 oz. REGULAR				
RECIPE 21F				
CHANNEL	FUNCTION	START	DURATION	MODIFIER
06	FD REGULAR COFFEE - SELECTION 1	2.8	3.70	.25
11	FD COFFEE WATER - SELECTION 1	0.8	10.60	
12	COFFEE LIGHTENER - SELECTION 1	2.2	1.00	.30
13	COFFEE SUGAR - SELECTION 1	3.8	1.60	.30
14	COFFEE SUGAR SUB - SELECTION 1	3.8	1.00	.25
15	WHIPPER-TROUGH - SELECTION 1	1.9	0.0	



INDICATES CHANNELS NOT NORMALLY USED IN THIS SELECTION

FOR ADDITIONAL INFORMATION ON CHANNEL USAGE - SEE APPENDIX IV - CHANNEL APPLICATION CHART



SELECTION #2 FRESH BREW DECAF COFFEE - 12 oz.

RECIPE 22B

CHANNEL	FUNCTION	START	DURATION	MODIFIER
07	COFFEE BREWER CYCLE	4.0	25.00	
09	BREWER FILL DELAY	7.4	3.60	
10	PRESSURE RELIEF DELAY	19.0	2.00	
16	LARGE GRINDER - SELECTION 2	0.0	0.00	.25
17	LG COFFEE AUGER - SELECTION 2	0.0	0.00	.25
18	DECAF (LG/MINI GRINDER) - SELECTION 2	0.2	1.60	.25
19	BREW WATER - SELECTION 2	5.1	5.80	
20	MAKE UP WATER - SELECTION 2	13.0	0.00	
21	COFFEE LIGHTENER - SELECTION 2	12.0	1.05	.30
22	COFFEE SUGAR - SELECTION 2	12.5	1.60	.30
23	COFFEE SUGAR SUB - SELECTION 2	12.5	1.40	.25
24	WHIPPER-TROUGH - SELECTION 2	11.3	0.0	

* ONLY ONE OF THESE CHANNELS MAY BE USED AT A TIME

SELECTION #2 FREEZE DRIED DECAF COFFEE - 12 oz.

RECIPE 22F

CHANNEL	FUNCTION	START	DURATION	MODIFIER
17	FD COFFEE - SELECTION 2	6.7	0.00	.25
18	FD DECAF - SELECTION 2	2.8	3.60	.25
20	FD WATER - SELECTION 2	0.8	10.60	
21	COFFEE LIGHTENER - SELECTION 2	2.2	1.05	.30
22	COFFEE SUGAR - SELECTION 2	3.8	1.60	.30
23	COFFEE SUGAR SUB - SELECTION 2	3.8	1.05	.25
24	WHIPPER-TROUGH - SELECTION 2	1.9	0.0	

 INDICATES CHANNELS NOT NORMALLY USED IN THIS SELECTION
 FOR ADDITIONAL INFORMATION ON CHANNEL USAGE -
 SEE APPENDIX IV - CHANNEL APPLICATION CHART



SELECTION #3 CUSTOM SELECT COFFEE - 12 oz. CAFE MOCHA				
RECIPE 23B				
CHANNEL	FUNCTION	START	DURATION	MODIFIER
07	BREW MOTOR CYCLE	4.0	25.00	
09	BREWER FILL DELAY	7.4	3.30	
10	PRESSURE RELIEF DELAY	19.0	2.00	
25	LARGE GRINDER - SELECTION 3	0.3	1.00	.25
26	LG COFFEE - SELECTION 3	0.2	1.20	.25
27	DECAF (LG OR SMALL GRINDER) SEL 3	0.2	0.00	.25
28	BREW WATER - SELECTION 3	5.1	4.30	
29	MAKE-UP WATER - SELECTION 3	12.3	0.00	
30	COFFEE LIGHTENER - SELECTION 3	10.6	0.65	.15
31	COFFEE SUGAR - SELECTION 3	10.9	1.12	.15
32	COFFEE SUGAR SUB - SELECTION 3	10.9	1.12	.15
33	WHIPPER-TROUGH - SELECTION 3	9.6	8.00	
34	CHOCOLATE AUGER - SELECTION 3	16.0	2.30	
35	CHOCOLATE WATER & WHIPPER - SEL - 3	15.0	3.55	

SELECTION #3 FREEZE DRIED CUSTOM SELECT COFFEE - 12 oz. CAFE MOCHA				
RECIPE 23F				
CHANNEL	FUNCTION	START	DURATION	MODIFIER
26	FD COFFEE - SELECTION 3	2.8	2.20	.25
27	FD DECAF - SELECTION 3	5.8	0.00	.25
29	FD WATER - SELECTION 3	0.8	6.80	
30	COFFEE LIGHTENER - SELECTION 3	2.8	.65	.15
31	COFFEE SUGAR - SELECTION 3	2.8	1.12	.15
32	COFFEE SUGAR SUB - SELECTION 3	2.8	1.12	.15
33	WHIPPER-TROUGH - SELECTION 3	2.5	8.00	
34	CHOCOLATE AUGER - SELECTION 3	11.0	2.30	
35	CHOCOLATE WATER & WHIPPER - SELECTION 3	10.0	3.55	



INDICATES CHANNELS NOT NORMALLY USED IN THIS SELECTION

FOR ADDITIONAL INFORMATION ON CHANNEL USAGE - SEE APPENDIX !V - CHANNEL APPLICATION CHART

SELECTION #4 FD GOURMET (or FD Tea) - 12 oz. SOLUBLE				
RECIPE 25				
CHANNEL	FUNCTION	START	DURATION	MODIFIER
41	FD GOURMET AUGER - SELECTION 4	2.8	1.80	.25
43	FD WATER - SELECTION 4	0.8	10.60	
44	LIGHTENER - SELECTION 4	2.2	1.05	.30
45	SUGAR - SELECTION 4	3.8	1.60	.30
46	SUGAR SUB - SELECTION 4	3.8	1.40	.25
47	WHIPPER-TROUGH - SELECTION 4	1.9	0.00	
52	SGC #1 AUGER - SELECTION 4	13.0	0.00	
53	SGC #1 WATER & WHIPPER - SELECTION 4	12.0	0.00	

SELECTION #5 - SGC #2 - 12 oz. SOLUBLE GOURMET COFFEE				
RECIPE 25				
CHANNEL	FUNCTION	START	DURATION	MODIFIER
54	SCG #2 AUGER - SELECTION 5	2.1	6.20	.00
62	SCG #2 WHIPPER - SELECTION 5	1.8	10.00	
63	SCG #2 WATER - SELECTION 5	1.0	10.20	

SELECTION #6 - SGC #1 - 12 oz. SOLUBLE GOURMET COFFEE				
RECIPE 26				
CHANNEL	FUNCTION	START	DURATION	MODIFIER
65	SGC #1 AUGER - SELECTION 6	2.0	6.15	
66	SGC #1 WATER/WHIPPER - SELECTION 6	1.0	10.20	

SELECTION #7 - 12 OZ. WHIPPED HOT CHOCOLATE				
RECIPE 27				
CHANNEL	FUNCTION	START	DURATION	MODIFIER
67	CHOCOLATE AUGER	2.1	6.60	
68	WATER/WHIPPER - CHOCOLATE	1.0	10.50	



INDICATES CHANNELS NOT NORMALLY USED IN THIS SELECTION

FOR ADDITIONAL INFORMATION ON CHANNEL USAGE - SEE APPENDIX IV
- CHANNEL APPLICATION CHART

213 ELECTRONICS CONTROL SYSTEM - INTRODUCTION

There are 18 modes in which the control system can operate. The various modes are used to access the accountability data, set up the machine and perform service diagnostics.

Mode 0 - The normal operating mode of the machine during which a user may establish credit and select a drink.

Modes 1 - 10 - Service modes accessible by operation of the "mode" switch inside the machine. This switch is accessible once the door is opened i.e. only the door key is required.

Modes 11 - 17 - Additional service modes accessible only if a key for the security switch is used. All security keys are identical.

DESCRIPTION OF MODES

Mode 0: Operate mode. Normal operating mode.

Door key required:

Mode 1: Display report. Displays accountability information.

Mode 2: Test vend. Allows one test vend without credit.

Mode 3: Manual flush cycle. Used to flush the mixing channels and bowls with water.

Mode 4: Set large drink prices. Used to set/check the prices of all large selections.

Mode 5: Set regular drink prices. Used to set/check the prices of all regular size selections.

Mode 6: Diagnostics. Checks all segments of the scrolling display, all indicator lamps and lists closed logic level switches.

Mode 7: Channel timed test. Selected channel is turned on for the normal vend duration time.

Mode 8: Channel continuous test. Selected channel is manually turned on until is manually turned off again.

Mode 9: Upload RS232C. Allows uploading of machine program from a programming device to the machine control board.

Mode 10: Download RS232C. Allows the downloading of the machine program from the control board to a programming device.

SECURITY KEY REQUIRED:

Mode 11: Machine configuration. Allows definition of machine type and options. Also controls default functions of the dual cup when one cup is sold out.

Mode 12: Set ingredient channel times. Used to set start and duration times and strength modifiers.

Mode 13: Set Options. Used to set payment and volume options.

Mode 14: Set discount bits. Used to indicate which selections may be discounted.

Mode 15: Not used on the 213 hot drink machine.

Mode 16: Load standard times and prices. Used to load factory standard time settings.

Mode 17: Smart display user message. Used to program the scrolling message using the machine selector panel.

This document is available free of charge to our customers at www.automaticproducts.com

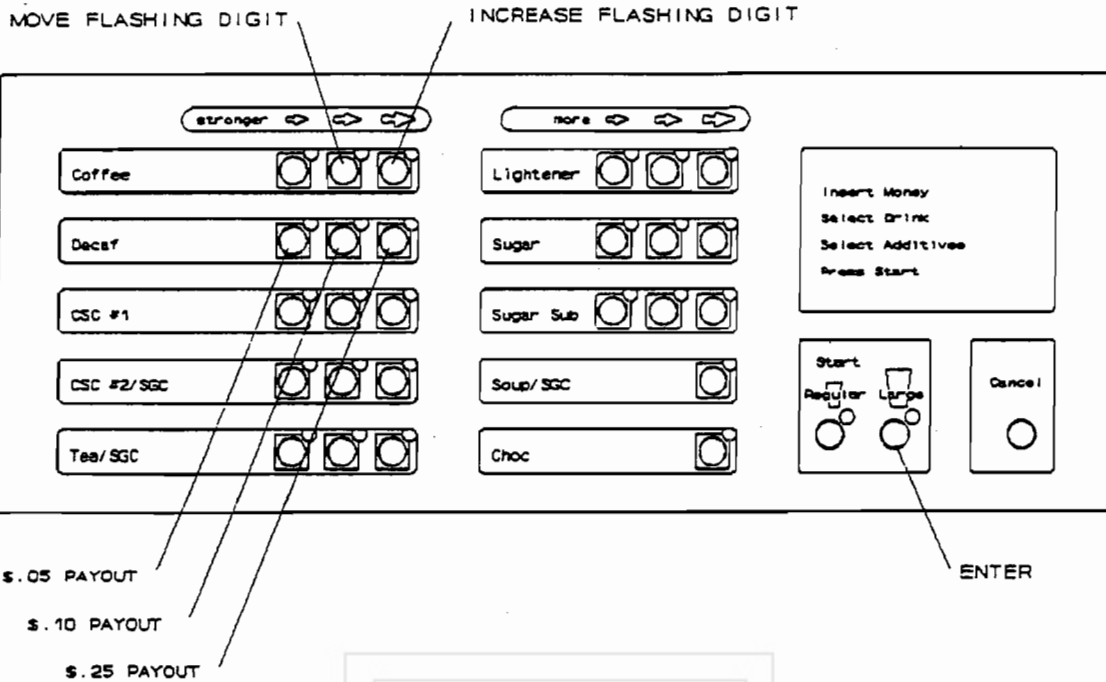

USE OF KEYBOARD

When in any of the service modes the selection panel switches perform different functions. A diagram showing the function of the switches is shown above.

COIN DISPENSE

At any time, in any service mode, the three switches for decaffeinated coffee (selection #2) can be used to dispense coins from the changer:

Mild strength -	Nickels
Regular strength -	Dimes
Strong -	Quarters

INCREASE & NEXT DIGIT BUTTONS

There are two buttons to carry out the changing of modes and values appearing on the scrolling display. Modes can also be incremented using the mode switch, inside the door.

The increase digit button (coffee strong) is used to increase the value of the flashing digit e.g. from "13" to "14". The value of the digit will return to "0" after "9".

The next digit button (coffee regular) is used to move to the next digit (indicated by the flashing character), like a watch set up, e.g. from "24" to "24" and then to "_24". Repeating this step will return the flashing digit to the right hand position.

ENTER

*Throughout this service manual, the word **ENTER** always refers to the large **START** (right hand) selection switch.*

SPECIAL BUTTONS

Additional functions are available with other switches and are explained in the appropriate sections of this manual.

TO EXIT SERVICE MODE

The service mode can be exited at any time by one of the following:

- Depress mode switch until scrolling message returns.
- Depress coin return button.
- Deposit coins or a bill into the machine.
- Remove and reapply power to machine or control board
- Leaving the machine without depressing any switches for 90 seconds will automatically return to the normal operate mode.



CAUTION: THE FOLLOWING PROCEDURES REQUIRES THAT THE MACHINE HAVE POWER APPLIED AND A POTENTIAL ELECTRICAL SHOCK HAZARD EXISTS.

MODE 1 - DISPLAY REPORT

Mode 1 contains the accountability information (MIS), is available in two different configurations. The first type of accountability is the type that has been available in previous software versions known as PRICE LINE MIS - ten customer settable price lines. These ten price lines are set in Mode 13, and are represented in Mode 1. The second, and newest type of MIS information available, will be referred to as PRODUCT INFORMATION MIS. Using the sequence MA, MB, MC, etc. this will represent the number of products sold for each selection by size. These two types of MIS are not interchangeable, and only one type is available in a single machine. The two flowcharts on the pages following Mode 1 explain the sequence and meaning of both types of MIS. **Both of these configurations also support a audit printout which is automatically transmitted whenever Mode 1 is entered. See directions below for using this function. This software version also contains 2 new counters M7 & M8, which are counters that record the number of free vends for large and regular drinks, respectively.**

The MIS information is a factory set option and is not changeable in the field except by changing the entire logic board!

The procedure for retrieving basic MIS information common to both types manually is as follows:

1. Open machine door. Turn 3 Amp (red) circuit breaker off then on.
2. Depress the mode switch once so the display indicates "MODE 01".
3. Depress the large **START** front panel selection switch, and following a 4 second delay for the transmission of MIS information, the display will indicate "M0 ", followed by " XXXX". This is the total vend count.
4. Depress the **START** front panel selection switch again and the display will indicate "M1 ", followed by "- XXXX.XX". This is the cash total taken by the machine.
5. Depress the **START** front panel selection switch again and the display will indicate "M2 ", followed by "- XXXX.XX". This is the cash value of all discounts given.
6. Depress the **START** front panel selection switch again and the display will indicate "M3 ", followed by "- XXXX.XX". This is the total value of bills taken.
7. Depress the **START** front panel selection switch again and the display will indicate "M4 ", followed by "- XXXX". This is the total number of discount vends.
8. Depress the **START** front panel selection switch again and the display will indicate "M5 ", followed by "- XXXX.XX". This is the total cash value of large drink vends.
9. Depress the **START** front panel selection switch again and the display will indicate "M6 ", followed by "- XXXX.XX". This is the total cash value of small drink vends.

10. Depress the **START** front panel selection switch again and the display will indicate "M7 ", followed by "- XXXX". This is the total number of large free vends, where free vend is defined as any selection sold at a price of \$.00 including 100% discount vends, Mode 2 test vends, Mode 13 FREE = Y, and winners.
11. Depress the **START** front panel selection switch again and the display will indicate "M8 ", followed by "- XXXX". This is the total number of regular size free vends following the same definition as M7.
 - ◆ The counters for M7 & M8 will count to a maximum of 9999 vends and will then roll over to 0000, and continue to count.
12. Depressing the **START** front panel selection switch again will cause the machine to display additional breakdowns of the vend totals by one of two methods. The style of MIS information contained in the machine is determined by the software. Which style is present can be determined by examining the software label - see chart on page 1.04. The first type of accountability is the type that has been available in previous software versions - TEN CUSTOMER SETTABLE PRICE LINES. These ten price lines are set in Mode 13, and are represented in Mode 1. The second type of MIS information available, will be referred to as PRODUCT INFORMATION. Using the sequence MA, MB, MC, etc. this will represent the number of products sold for each selection by size. The two flowcharts on the following pages explain the sequence and meaning of both types of MIS.
 - ◆ If multiple price lines are being used - set the most commonly used prices in the lowest possible price line counter. These price line counters are set in **MODE 13**.
13. Press coin return button to return to operate mode.

Note: The next mode can be entered by either pressing the **MODE** switch inside the door or by using the **increment** digit and **next digit** switches on the selection panel.

MIS AUDIT PRINTER

A new function supported by the AP213 allows the use of a small battery powered printer to record the accountability information contained in Mode 1. The printer should be settable to the following format:

1200bps, ASCII, 8 data bits, 1 stop, no parity, full duplex

One recommended printer is manufactured by Seiko, Model DPU-411-21BU.

TO USE THE AUDIT PRINTER FUNCTION:

1. Turn 3 amp (red) circuit breaker off. Swing out both cup dispensers and lower logic board.
2. Locate P2 connector in center of board and plug 11 pin connector from printer onto P2.
3. Restore power and press mode switch one time, display should show "MODE 01".
4. Depress large "START", and all MIS information will be transmitted to the printer and then begin showing the MIS on the display - see Step 3 on previous page.

MIS FLOWCHART BY PRICELINE

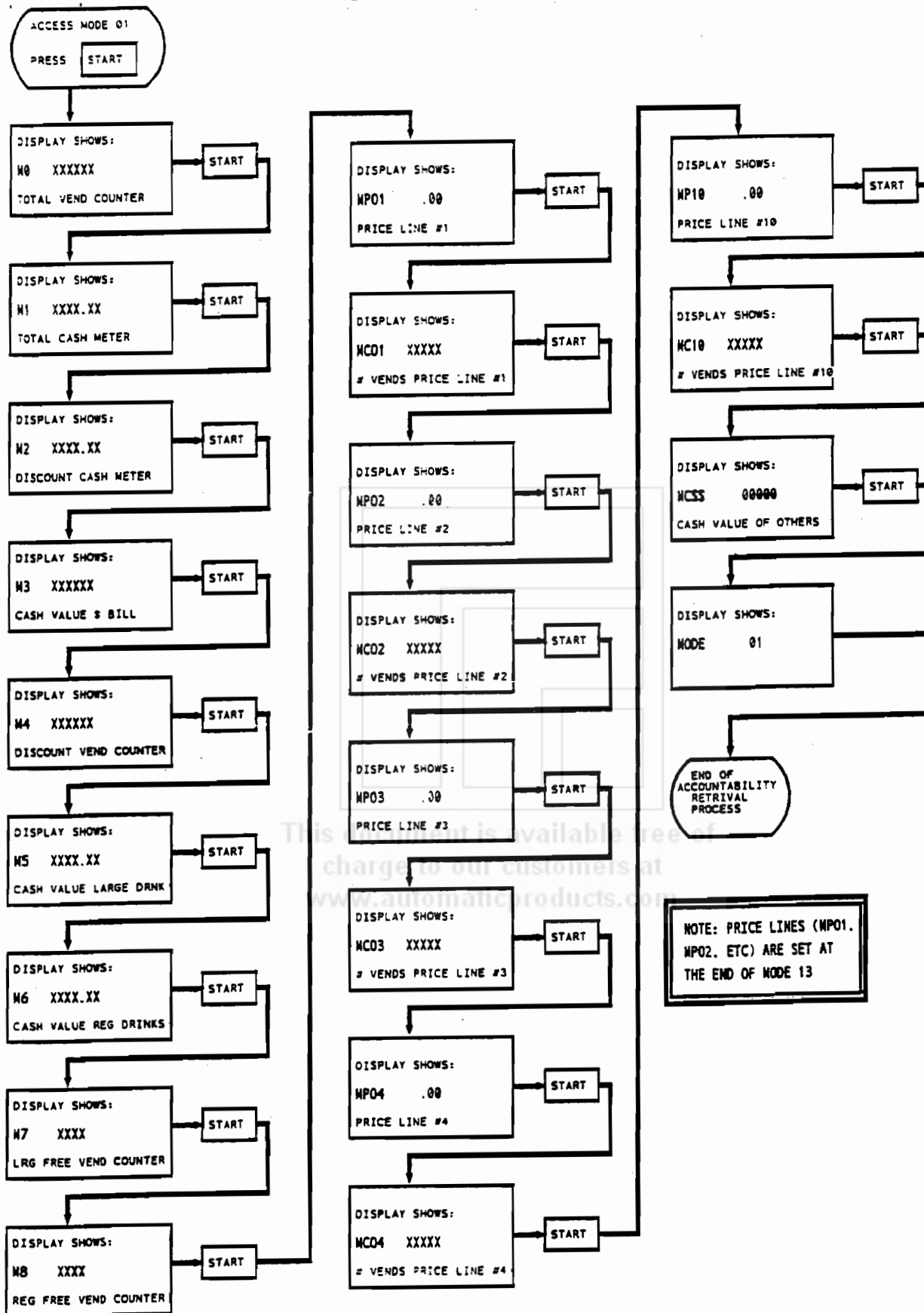

STEPS REPEAT FOR MC05 THROUGH MC09

NOTE: PRICE LINES (MP01, MP02, ETC) ARE SET AT THE END OF NODE 13

MIS FLOWCHART BY PRODUCT INFORMATION

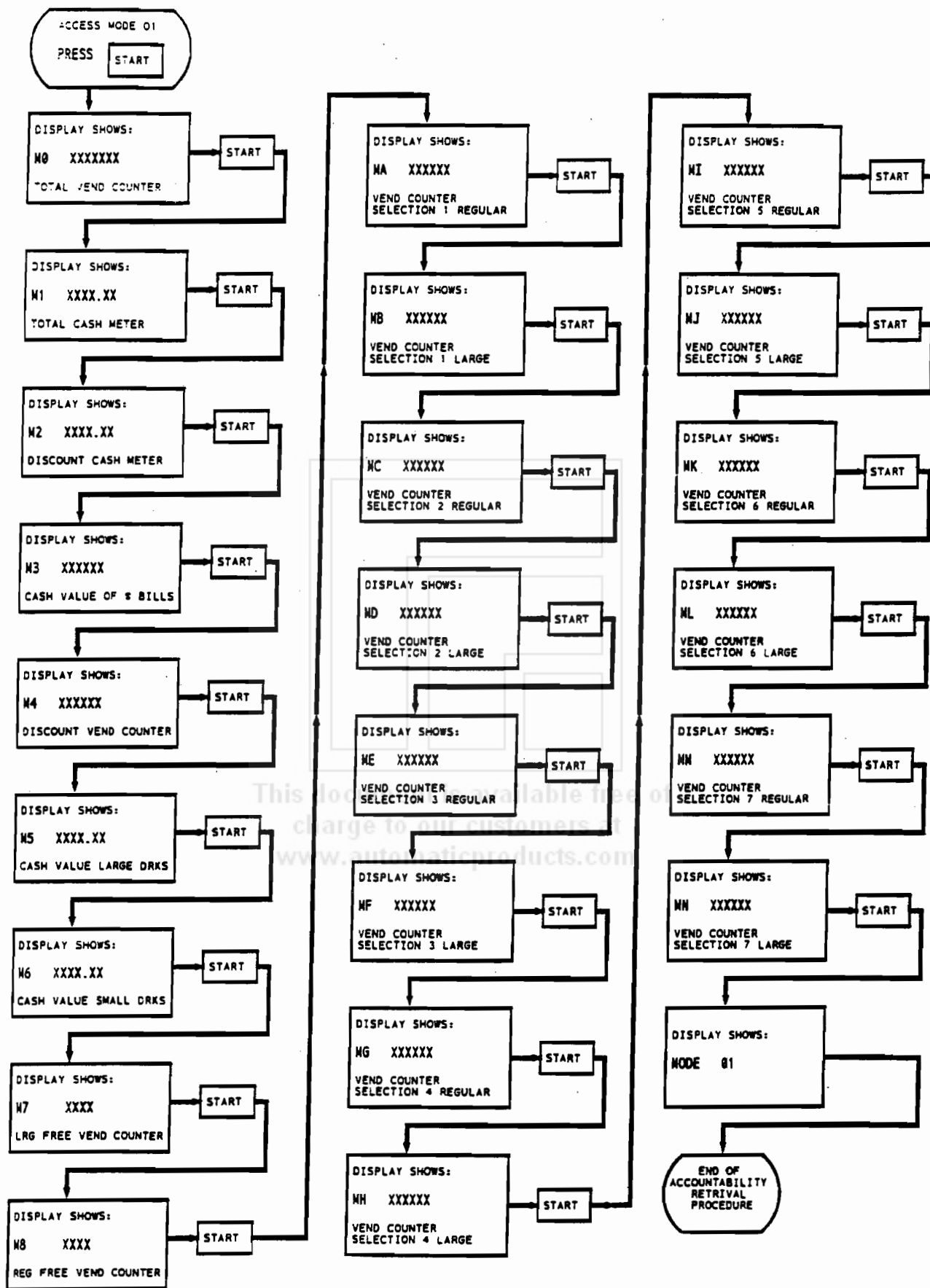

MODE 2 - TEST VEND

MODE 2 provides a means to allow one test vend. This test vend is NOT counted in M0 in the MIS. If price line MIS is in use, the vend will be recorded in the first available price line that is set to \$0.00.

1. Open machine door.
2. Depress the mode switch until the display indicates "MODE 02".
3. Depress the START front panel switch, the display should indicate "THANK YOU" and then scroll the user message signifying that the machine is in the normal user mode.
4. The next vend will be a vend without credit.

MODE 3 - FLUSH CYCLE

MODE 3 provides a method for route service or location attendant personnel to perform a rinse of the brewer and commodity delivery system during routine servicing of the machine. This flush cycle should not be operated while the machine is unattended, however other tasks, such as replenishing cups may be done while the flush cycle is operating.

1. Open machine door.
2. Depress the mode switch until the display indicates "MODE 03".
3. Depress the START front panel switch. The machine will then show "OPT Y/N". Use either the increase or next digit switch to change the Y to flashing.
4. Depress the START front panel switch. The machine will then start a series of 3 flush cycles that will energize the brewer, each valve and whipper in sequence.
5. Approximate run time for the flush cycle is one and one-half minutes.
6. At the end of the flush cycle the lamp on the cupwell bezel will go out while the display will continue to indicate "MODE 03" and the Y that was changed above will reset to N.

AUTOMATIC FLUSH CYCLE

The machine is equipped with an automatic flush cycle which is carried out automatically every 12 hours. The automatic flush will occur as long as the autoflush enable switch is connected to the logic board and the door is closed. The volume of the water dispensed during the flush cycle is preset during manufacture and should not be adjusted. If you experience problems with the cycle, either due to infrequent service or volume of liquid dispensed, you may reduce the duration of the valves' operation.

◆ **DO NOT ATTEMPT TO CHANGE THE CLEANING CYCLE CHANNELS.**

The automatic flush will operate every 12 hours from the last time that the machine was powered up. If the machine is being used at the end of the 12 hour period it will wait for 10 minutes of complete inactivity before carrying out the cycle.

The automatic cycle can be disabled by removing connector P12 from the logic board or by removing one wire from the flush enable switch above the door lock.

It will still be possible to carry out a manual flush using MODE 3.

MODE 4 - SET PRICES FOR LARGE DRINK

Mode 4 now sets the selling price for LARGE size drinks only. Both Mode 4 and 5 must be set for the large and regular drinks to vend correctly.

1. Open machine door.
 2. Depress the mode switch until the display indicates "MODE 04".
 3. Depress the START front panel switch, the display will indicate "PRICE .00"
 4. Use the next digit to move the blinking cursor to the required digit in the display. To increase the selected digit press the increment digit switch. The value of the digit will return to "0" after "9".
 5. When the desired price has been set on the display, press the "START" switch. The display will then indicate "SELECTION".
 6. Depress the selection switches (normal panel buttons) to assign the set price to the drink selections. The selection LED will light up to indicate that the price has been set. Repeat for all selections at this price.
 7. Depress the "START" switch and the display will indicate "PRICE . ". To verify the prices depress the appropriate selection switches. The price will be displayed for each selection pressed. The LEDs will remain on until a new mode is entered.
 8. Depress the "START" switch and the display will return to "MODE 04".
- ◆ *SETTING PRICES TO 0.00 WILL SET A SELECTION TO FREE VEND.*
- ◆ *SETTING A PRICE TO 99.99 WILL DISABLE A SELECTION AND CAUSE THE MESSAGE "MAKE ANOTHER SELECTION" TO APPEAR WHEN THE SELECTION IS PRESSED. THIS IS USEFUL FOR BLOCKING UNUSED SELECTIONS OR DISABLING A SELECTION WHEN IT IS OUT OF ORDER.*

MODE 5 - SET PRICE REGULAR SIZE

This mode is used to set the prices for the regular size drink. They are a completely separate set of prices from the large prices. Both sets of prices must be set for the machine to operate correctly. The procedure is identical to MODE 4.

- ◆ *If you are disabling a selection by setting the price to 99.99, you must set this price in both Mode 4 & 5.*

MODE 6 - DIAGNOSTICS

Mode 6 will provide a means to test the scrolling display segments, LEDs on the selection panel, and all logic level switches. This function includes a means to test all selection panel switches.

1. Open machine door.
2. Depress the mode switch until the display indicates "MODE 06".
3. Depress the **START** front panel switch. The scrolling display will have all segments on and all LEDs will be illuminated until MODE 6 is exited.
4. The display will then indicate all the closed logic level switches by switch number, one after another. This facility, along with the list of switches, can be used to locate problems in the machine. See the troubleshooting section in the service section of the manual.

MODE 6 SWITCH LISTING - NORMAL OPERATION

SWITCH #	INDICATION	WILL APPEAR IN	NORMAL OPERATION
23	RIGHT START SWITCH		N
24 or below	faulty membrane (selector)		N
25	discount switch		Y/N
26	auto flush enable switch		Y/N
27	bucket switch activated		N
28	CUP SENSOR INPUT		Y/N
29	<i>SELECTION 3 MILD</i>		N
31	<i>LEFT START SWITCH</i>		N
33	brewer water switch		Y
34	brewer cycle switch		Y
35	brewer delay switch		N
36	not used		N
37	logic jumper - heater voltage		Y
38	<i>SELECTION 3 MEDIUM</i>		N
40	heater tank level probe (ELLC)		N
41	<i>SELECTION 3 STRONG</i>		N
46	REGULAR CUP PRESENT SWITCH		Y
47	LARGE CUP PRESENT SWITCH		Y

5. At the end of the diagnostics the display will indicate "MODE 06".

SELECTOR PANEL TEST

1. Access MODE 6 as instructed above.
2. Press **START**, and observe the numbers that appear in scrolling display. No numbers below 24 and 29,31,38 and 41 should appear. These are all selection switches and none should be closed during normal operation.
3. Record all numbers that appear. If you suspect you have a defective selector panel switch, press **START** again, and immediately press the suspected malfunctioning selection button. Observe the numbers on the scrolling display. Compare these numbers to the list of numbers recorded above - a new number

should appear in the range 00 through 24, 29, 38 or 41. This indicates that the switch is working correctly. This test may be repeated as many times as necessary to test any questionable switches.

CHANNEL TEST

Modes 7 & 8 provide a means to test the function of a specific channel without running an entire vend. This function allows for testing a specific device - motor, valve etc for trouble shooting purposes. Mode 7 will test a channel for the duration time that channel is set for, while Mode 8 will continuously provide power to the device until the power is removed by pressing the **START** button again.

MODE 7 - CHANNEL TIMED TEST

1. Open machine door.
2. Depress the mode switch until the display indicates "MODE 07".
3. Depress the **START** front panel switch. The display will indicate "CH 00".
4. To select a channel use the next digit switch and increase digit" switches to select the desired channel number.
5. Depress the **START** switch and the selected channel will operate for the normal vend duration time.
6. When the selected channel is finished the display will indicate "MODE 07".

MODE 8 - CHANNEL CONTINUOUS TEST

1. Open machine door.
2. Depress the mode switch until the display indicates "MODE 08".
3. Depress the **START** front panel switch. The display will indicate "CH 00".
4. To select a channel use the next digit switch and increase digit" switches to select the desired channel number.
5. Depress the **START** switch and the selected channel will be turned on. It will stay on until the **START** switch is depressed again. The display will then indicate "MODE 08".

MODE 9-UPLOAD SETTINGS TO MACHINE

At present the only device capable of being used to upload data to the machine is an IBM compatible computer or another machine.

1. Open machine door.
2. Depress the mode switch until the display indicates "MODE 09".
3. Connect the programming device cable to P2 on the control board.
4. Depress the START switch before sending the file to the machine control board.
5. The display will remain blank during the file loading time. At the end of the file loading the user message will scroll on the display again.

MODE 10-DOWNLOAD SETTINGS FROM MACHINE

At present the only device capable of being used to download data from the machine is an IBM compatible computer or another machine.

1. Open machine door.
2. Depress the mode switch until the display indicates "MODE 10".
3. Connect the programming device cable to P2 on the control board.
4. Depress the START switch. This starts sending the file to the external programming device.
5. The display will remain blank during the file sending time. At the end of the file sending the user message will scroll on the display again.

MACHINE TO MACHINE UPLOAD/DOWNLOAD

It is also possible to transfer the settings and data from one machine to another, using a special connecting cable (part # 33784). The procedure is as follows:

1. Connect each end of the cable to the two P2 connectors on each machine control board.
2. Put the machine which has already been set up correctly (machine A), into mode 10.
3. Put the machine to be set up (machine B) into mode 9. Machine B needs to be in an in order condition to receive the download (loaded with cups, full of water, bucket switches free) . Depress the START switch.

4. Depress the START switch on machine A.
5. The scrolling display will go blank on machine B. When the scrolling display returns, the file transfer is complete.

- ◆ Due to the complexity of the information that is transferred during the upload or download, some precautions must be observed. The information that is required is located on the paper label on the main program chip located on the logic board. The diagram below explains the information contained on the label.

DATE CODE ⇒
ORDER # ⇒
CHART # ⇒

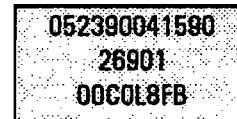

- ◆ For all model 213, the first three digits of the chart number MUST match for a successful transfer of information. In the example above, the first 3 digits are OOC. This means that the settings in this machine would transfer successfully to any other machine whose chart number started with OOC.

INFORMATION CONTAINED IN TRANSFER

The information in the data transfer file between machines or the computer and the vending machine in either direction is:

PRICE SETTING INFORMATION - Includes information from MODE 4 for single cup machines and MODE 4 & 5 for Dual Cup models.

CONFIGURATION - Exactly duplicates the settings in MODE 11.

CHANNEL SETTING - Copies the settings of all ingredient channel settings located in MODE 12.

PAYMENT OPTIONS - Copies the settings of all options located in MODE 13 for payment and other functions.

DISCOUNT SELECTION - Copies the setting of the discount bits in MODE 14.

CAUTION: DOWNLOAD WILL NOT TRANSFER THE 10 PRICE LINE SETTINGS FROM THE END OF MODE 13. THESE ARE CONSIDERED PART OF THE MANAGEMENT INFORMATION SYSTEM (MIS). NO MIS INFORMATION IS TRANSFERRED. THE STANDBY SCROLLING MESSAGE IS NOT TRANSFERRED.

For additional information about computer transfer capabilities, contact Technical Services Department.

MODE 11 - MACHINE CONFIGURATION

The function of MODE 11 is to determine the type of machine the software is installed in and what fresh brew options are available. Also included are the options that control the dispensing of cups and operation of the cup dispensers when one cabinet is empty.

- ◆ **THE FUNCTIONS FOR MODE 11 ARE VERY SPECIFIC AND DIFFERENT FOR EACH OF THE CANISTER RACK CONFIGURATIONS.**
- ◆ **MAKE SURE YOU ARE USING THE CORRECT MODE 11 TABLE FOR YOUR SPECIFIC MACHINE - SEE CANISTER RACK INDEX CHART ON PAGE 1.07**

1. Open machine door.
2. Insert security key into the service key switch, turn the switch to the "on" position and then back to the "off" position. This allows the key to be removed and prevent it being left in the machine in error.
- ◆ The correct function of the key switch is: on then off - the key should always be in the position where key can be removed.
3. The display should indicate "MODE 11".
4. Depress the **START** switch. The display will indicate "CONFIG H/B/C". The "H" should be flashing to indicate that the machine is set up as a 213 hot drink machine.
5. If the "H" is not flashing, after having just installed a new control board or new software for example, press the **change digit** switch until it is. Then depress the **START** switch. The machine will then jump automatically to mode 16 to load the default values appropriate for the 213 machine (see page 3.20xxx for additional information on board replacement).
6. If the "H" was flashing correctly continue with the configuration by depressing the **START** switch.
7. The machine will then advance through a series of **seven** questions. Each selection is made by depressing the **change digit** switch until the "Y" (yes) or "N" (no) is flashing and then activating the selection by depressing the **START** switch. The flashing character indicates the selected choice. The charts at the beginning of rack configuration section provide the choices available for each type of rack.
8. When the **START** switch is pressed for the final question the display will indicate "MODE 11".

Note: It is important to return to the "MODE 11" on the display to ensure that the new values are loaded.

DEFINITION OF CUSTOM SELECT COFFEE

CUSTOM SELECT COFFEE (abbreviated CSC) is the name of the selection assigned to at least the third prime selection. A number of new channels are available which allow you to create a custom drink using existing products in the machine. A few examples of this might be: Cafe Mocha defined as brewed coffee combined with whipped chocolate or Balanced Blend, a half regular, half decaf fresh brewed coffee. This selection - CUSTOM SELECT COFFEE allows the operator to create their own special drink.

- ◆ FOR ADDITIONAL INFORMATION ON CUSTOM SELECT COFFEE - SEE MODE 12

OPTION 5,6,7

These three options control the function of the dual cup dispenser. Option 5 allows the choice between a machine containing two size cups or one which has a larger quantity of a single size cup. Options 6 & 7 allow control of the cup dispenser in the event that one size cup is not available to vend. If either or both of the options are set to "N" and that cup size is selected but not available, the scrolling display will show "USE OTHER CUP SIZE". If either or both of the options are set to "Y" and the correct change is not available, then a drink may not be delivered.

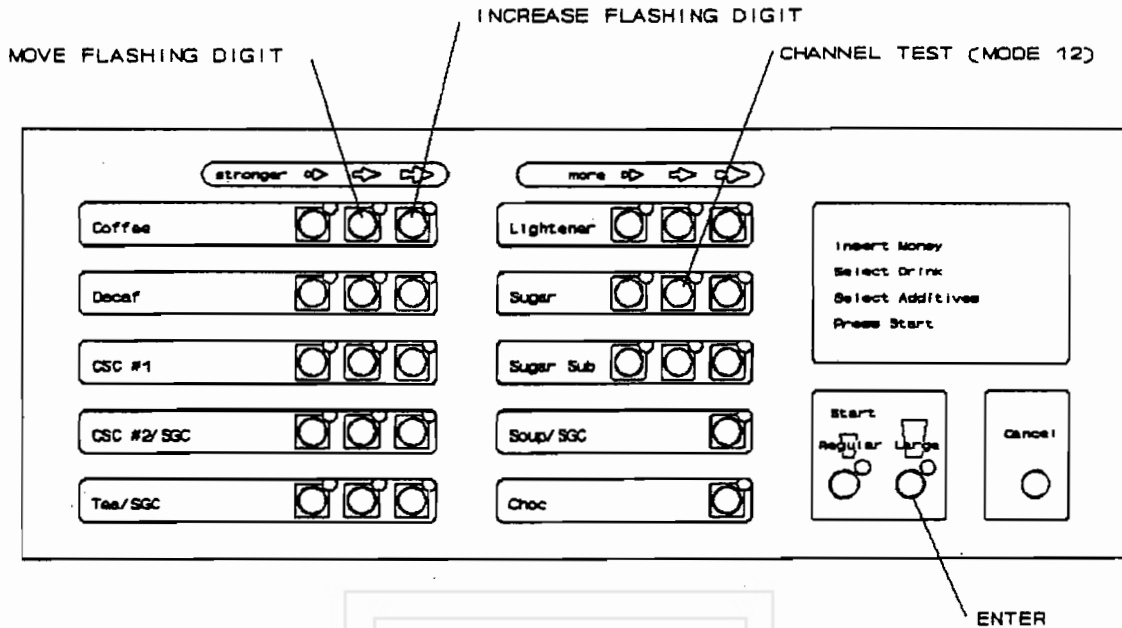

MODE 12 - SET TIME CHANNELS

The primary function of Mode 12 is to allow access to the numerous channels available for each selection. Each selection in the machine has a number of channels organized into a **RECIPE** - the correct arrangement of channels in each recipe is what creates a specific drink. For example, one of the simplest recipes is for a hot chocolate selection. The list of the channels required for a hot chocolate selection are:

- Channel 02 Hot vend cycle
- Channel 03 Cup drop start pulse
- Channel 67 Chocolate water & whipper
- Channel 68 Chocolate auger

Each of these channels, when combined in the correct order, in the appropriate amounts, will deliver a cup of hot chocolate. By increasing the number of channels available for a selection, the flexibility of that selection increases. **The selection that has this maximum flexibility is named "CUSTOM SELECT COFFEE" and is the third (and occasionally the fourth) prime selection on the left side of the selector panel.** Because each of the five prime selections are directly affected by the setting of the first four options in Mode 11, the function of the "CUSTOM SELECT COFFEE" is directly affected by whether the machine has fresh brewed coffee or freeze-dried coffee. The "CUSTOM SELECT COFFEE" is abbreviated as CSC in the channel lists.

- ◆ ALL ADJUSTMENTS TO INGREDIENTS ARE MADE FOR THE LARGE SIZE DRINK, THE SMALL SIZE DRINK WILL HAVE THESE ADJUSTMENTS MADE AUTOMATICALLY BY THE VOLUME SETTING IN MODE 13.

The directions for accessing the ingredient channels in MODE 12 are as follows:

1. Open machine door.
2. Insert security key into the service key switch, turn the switch to the "on" position and then back to the "off" position.
3. Depress the mode switch until the display indicates "MODE 12".
4. Depress the **START** switch. The display will indicate "CH 00".
5. To select a channel use the next digit switch and increase digit" switches to select the desired channel number. See figure above for location of switches.
6. Depress the **START** switch and the start time will be displayed in the following format - "START 00.0". This is the time from the beginning of the vend cycle to when the channel starts.
7. To change the start time, the next digit switch can be depressed repeatedly to move the flashing character to the left, to the digit to be changed and the increase digit switch depressed to increase the value of the digit.
8. When the required start time has been set, depress the **START** switch. This will change the previous start time to the new start time and advance to display the duration time. The display will be in the following format - "DUR 00.00".
9. The duration time can be changed by use of the next digit and increase digit switches as explained in step 7 above..
10. When the required duration time has been set, depress the **START** switch. The new duration time will replace the old time. If the channel has a modifier the display will indicate "MOD 0.00". If there is no modifier the display will indicate "MODE 12".

11. The duration sets the ingredient throw for the medium strength or middle selection e.g. regular coffee. The modifier value is the percentage increase and decrease in ingredient throw for the strong and weak selections on the selection panel. The modifier is set by means of the next digit and increase digit switches. By depressing the START switch the new modifier will replace old one. The display will then indicate "MODE 12".

12. The selected channel can be tested by depressing the CHANNEL TEST switch (middle light). The channel will be turned on for the normal vend duration. The display will indicate "MODE 12".

◆ Each channel to be tested must be "ENTERED" before it is tested - otherwise the test will return to the last channel tested.

Note: It is important to return to the "MODE 12" on the display to ensure that the new values are loaded.

All times listed are approximations, and should be adjusted for proper gram throws which are dependent upon regional variation in product and customer tastes. To assist you, a chart which provides approximate gram throws for normal products are available in Appendix I. While adjusting times, especially START or DURATION times of either product or water, the primary premise for correct operation of the machine will depend upon maintaining the proper sequence of liquid and ingredients: dry ingredients should always fall into flowing liquid and should always be followed by flowing liquid to achieve a complete and thorough rinse of the mixing bowl or mixing channel. Once the correct rinse time for a water channel has been set, the correct cup level should be set using the metering screw on the respective commodity valve.

All the channels listed in each of the recipes are available for use. However, some of the channels will have 0.00 listed for a duration. This indicates that a channel is not being used in the current drink, but may be used if required.

FOR ADDITIONAL INFORMATION ON CHANNEL USAGE - SEE APPENDIX IV - CHANNEL APPLICATION CHART

The recipes for selections using brewed coffee listed in each of the configurations listed in Section 1 of this manual, are factory set to be used with all the water being delivered to the brewer via the brew water valve. The Open Cylinder Delay (channel 9) is adjustable to pause the brewer to allow all water for brewed drinks to be delivered through the brew water valve. If makeup water is added to any of the brewed coffee or CSC fresh brew drinks, all times for the total water delivered to the cup will have to be readjusted.

CUSTOM SELECT COFFEE

CREATING YOUR OWN RECIPE

Since the components on the Motor Control Board are shared to operate different drink selections, attempting to operate two ingredients at the same time will create a conflict. Therefore, some rules must be followed when creating the recipe for your CUSTOM SELECT COFFEE. The charts on the previous pages contain times that have all these calculations considered. As long as your times do not exceed the durations or modifiers by an extreme amount, you should not have to perform any of these calculations.

1. Only one prime selection (LG regular coffee, fresh brew decaf, all FD augers, chocolate and soup) motor should be on at a time.
2. Only one prime selection (same as #1) water valve may be on at a time.
3. No trough whipper (channels 15,24,33,47,61) may have a START time less than 1.9 seconds.
4. A minimum of .1 second should be allowed between one device (motor or valve) turning off and the next similar device turning on. This is defined as the SEPARATION TIME.

The only exception to rule #1 is the large grinder. The large grinder can be used in combination with any other prime selection motor because it has a separate control circuit. As an example, below is list a sample calculation to determine the start time for the second coffee in a half regular, half decaf for an 8 1/2 ounce selection using a dual hopper (DH) swing out bracket.

START TIME			
DECAF LG CANISTER	= 0.0		1
DURATION			
DECAF LG + 2	= HALF DECAF TIME		
2.40 seconds + 2	= 1.20 seconds		2
MODIFIER DECAF LG	= .25 (25%)		
MODIFIER x DURATION	= ADDITIONAL TIME DECAF LG CANISTER IS ON		
.25 x 1.20	= .30		3
SEPARATION TIME	= .10		4

Using the above figures the minimum start time for the regular LG motor would be:

$$\begin{aligned}
 & \text{LG} \\
 \text{START} &= \text{START} + \text{DURATION} + \text{MODIFIER} + \text{SEPARATION} \\
 &= 1 + 2 + 3 + 4 \\
 1.6 &= 0.0 + 1.20 + .30 + .1
 \end{aligned}$$

The minimum start time for the regular LG motor (channel 6) would be 1.6 seconds, but please note if the duration or modifier is changed, then the START time for the LG motor should also be changed using the new times in the same formula.

MODE 13 - SET OPTIONS

MODE 13 contains a series of options and settings that provide the operator control over several payment options and settings that control the size of the regular cup. When using any of the Y/N (Yes/No) options, the letter that is flashing is the current setting of the option. *Mode 13 will now provide the option of setting a separate discount for the large and regular size cup.*

1. Open machine door. Insert security key into the service key switch, turn the switch to the "on" position and then back to the "off" position.
2. Depress the mode switch until the display indicates "MODE 13".
3. Depress the START switch. The machine will then advance through a series of questions and options. Each Y/N selection is made by depressing the change digit switch until the "Y" (yes) or "N" (no) is flashing and then activating the selection by depressing the START switch. The following questions are indicated on the display:

FORCE Y/N Y - Forced i.e. User must make a vend before change is returned
N - Normal

FREE Y/N Y - Free vend enabled on all selections
N - Normal prices apply

MS1600 Y/N Y - European Executive changer installed
N - US changer installed

ESCROW Y/N Y - Bill validator will escrow any bill that takes the credit above the highest vend price. No further bills will then be accepted. If the coin reject is pressed the bill will be returned.
N - Bills are stacked immediately.

MULTI Y/N Y - More than one vend can be made before change is returned.
N - Single vend - Change is returned immediately.

DISCL 1.00 *Any large selection enabled for discount in Mode 14 will be discounted by the factor set in this display. The discount price is obtained by multiplying the vend price by the discount factor e.g. 50¢ x .80 = 40¢. The discounted price will be in effect when the discount switch is operated.*

FREE CT 00 This option allows a free drink after a given number of vends. The number in the display can be set between "01" (every vend) and "255" (every 255th vend is free). If the number is left at "00" no free vends will be given.

VOLUME .75 This setting expressed as a percentage (%) allows the setting of the regular as compared to the large drink - Example: 12oz.(large drink) X .75 (75%) = 9oz (regular drink). See chart on next page for conversions.

DISCR 1.00 *Any regular size selection enabled for discount in Mode 14 will be discounted by the factor set in this display. The discount*

price is obtained by multiplying the vend price by the discount factor e.g. 50¢ x .80 = 40¢. The discounted price will be in effect when the discount switch is operated. This message replaces the previously unused "VOL D" message.

The DISCOUNT PERCENTAGE for the large and small are now split. "DISCL" applies only to the LARGE drinks, and "DISCR" applies only to the REGULAR size drink. For the Discount switch to act as a free vend switch, both percentages must be set to 100% (1.00). Both percentages are set to 1.00 when the machine leaves the factory. If you desire to vend only one cup size for free, then the free size should be set to 100% and the size that must be purchased should be set to 0% (.00). Other combinations of percentages can be used to create a discount for using your own cup, or any other type of promotion, however all selections should be tested with both size drinks to ensure correct operation.

5. Depress the START switch. If the display returns to MODE 13, then the machine is equipped with PRODUCT INFORMATION MIS and you may exit the service mode. If the display indicates "PRICE1 .XX" then the machine contains PRICE LINE MIS, and you should continue with the setting of the ten price lines. PRICE1 .XX is the price setting for the first price line. There are ten price lines that can be set to the required values. The control will then increment the count every time a vend is made at that price (or an equivalent price obtained by discounting a higher price).

6. Set the required price using the increase digit and next digit buttons.

7. Depressing the START switch will increment through the 10 price line values:

"PRICE2 .XX"

"PRICE9 .XX"

"PRICE0 .XX"

Each price line can be set to a different value. Leave any unused prices set to .00.

- ◆ The first available price line set to .00 will record all MODE 2 test vends, all 100% discount vends and all FREE CT (winner) vends.

8. Depressing the START switch completes the selection and returns to the beginning of the mode. The display will indicate "MODE 13".

Note: It is important to return to the "MODE 13" on the display to ensure that the new values are loaded.

VOLUME % CHART ON NEXT PAGE ➔

VOLUME % CHART FOR REGULAR CUP SIZE

2) READ ACROSS & ENTER THIS % IN Mode 13 Volume %	1) FIND LARGE CUP VOLUME HERE AND READ DOWN TO SMALL CUP VOLUME			
	Large cup size (oz)			
	9	10	11.5	12
85%	7.65	8.5	9.75	10.2
83%		8.25		
80%	7.2	8.0	9.2	9.6
78%	7.0		9.0	
75%	6.75	7.5	8.6	9.0
72%			8.25	
70%	6.3	7.0	8.00	8.4
69%				8.25
65%	5.9	6.5	7.5	7.8
61%			7.0	
60%	5.4	6.0	6.9	7.2
58%				7.0
55%	5.0	5.5	6.3	6.6

MODE 14 - SET DISCOUNT BITS

Mode 14 permits setting which drinks are permitted to be discounted when the discount switch is on. If consistent problems are encountered with the discount switch being left on accidentally, and drinks being given away free unintentionally, the easiest method to disable the switch is to access Mode 14 and press START twice. This will clear all previously set discounted selections.

1. Open machine door.
2. Insert security key into the service key switch, turn the switch to the "on" position and then back to the "off" position.
3. Depress the mode switch until the display indicates "MODE 14".
4. Depress the START switch. The display will indicate "SELECTION".
5. All previously set discounts will be reset. Depress the selection switches (normal panel buttons) to set the drink selections to be available for discount. The selection LED will light up to indicate that it is discounted. If the selection is pressed again the LED will go out again to indicate that it is not discounted.
6. Depress the START to complete the selection. The display will indicate "MODE 14".

NOTE: Changing the options in MODE 11 may require resetting the discount assignments.

- ◆ Entering MODE 14 and pressing START twice will clear all selections previously set for discount.

MODE 15 - NOT USED ON THE 213 HOT DRINK MACHINE

MODE 16 - LOAD STANDARD SETTINGS

The function of Mode 16 is to provide a means to install new software or to return the settings in a machine to the original factory settings contained in the EPROM. This process is commonly known as initialization. These settings can be confirmed by checking the label on the program chip - see chart on page 1.04 for additional information. If an OUT OF ORDER M10 code appears on the scrolling display, the only way to eliminate this code is to perform a Mode 16 reset. The information changed during this initialization procedure is the same as contained in a machine to machine transfer - see page 2.08 for a list of this information. The Mode 16 reset can also be considered a "safety net", which will allow you to eliminate any incorrect or scrambled information which is preventing the machine from operating correctly. In most cases, this will restore the machine to an operating condition.

1. Open machine door.
2. Insert security key into the service key switch, turn the switch to the "on" position and then back to the "off" position.
3. Depress the mode switch until the display indicates "MODE 16".
4. Depress the START switch and the display will indicate "MODE 16" again. While it appears nothing has changed, you have entered Mode 16.
5. In order to prevent accidental loading of the standard times and settings, it is necessary to enter a code number or password. Using the increase digit and next digit switches change the "16" to "27" and then depress the START switch. The display will go blank.
 - ◆ Changing the "16" to a "27" should be considered a password that is the only way to reload the factory standard times. To confirm that MODE 16 was properly done turn power off and back on. If configuration and the values in MODES 11, 12 and 13 remain the same, then the reload was correctly done.
6. When initialization and loading of the standard values is complete the display will scroll the user message again.
7. Return to mode 11, recheck configuration and set the machine options.
 - ◆ If you have been supplied with a "CUSTOM CHIP" (indicated by a letter higher than J in the fourth position of the of the CHART # as shown in the diagram on the page describing the EPROM label) you are reloading the times and settings provided when the "CUSTOM CHIP" was created.

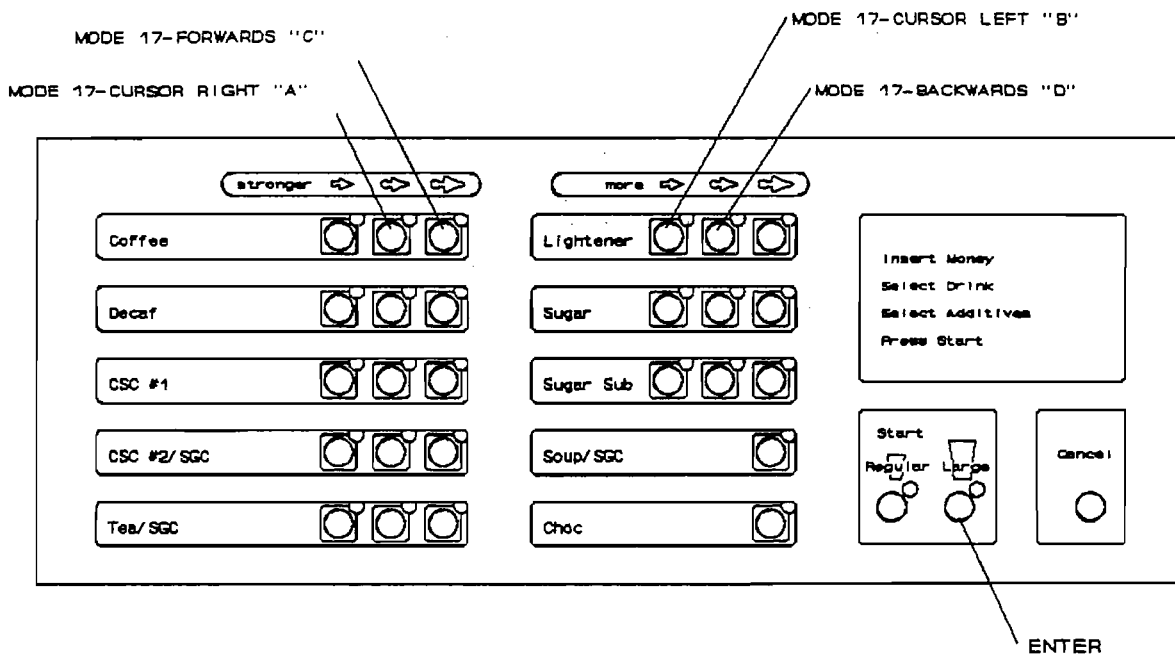

MODE 17 - PROGRAMMING USER MESSAGE

Approximately 85 spaces including blanks and punctuation are available for a user message to be loaded into the scrolling display by using Mode 17. For best results leave 5-6 spaces blank at the beginning of your message. Doublecheck for correct spelling - errors in the middle of the message are difficult to correct.

1. Open machine door.
2. Insert security key into the service key switch, turn the switch to the "on" position and then back to the "off" position.
3. Depress the mode switch until the display indicates "MODE 17".
4. Depress the **START** switch. The first nine characters of the user message will be displayed with the cursor (flashing character) at position eight and a special start character () at position one.
5. The message can now be changed by moving through the message to the characters that need changing and then selecting from the list of characters and symbols.
6. **CURSOR RIGHT** -
Switch "A" (coffee regular) moves the cursor to the right in the message. Depressing switch "A" for less than one second will move the cursor right one character at a time. If depressed longer the rate of movement will speed up.
7. **CURSOR LEFT** -
Switch "B" (light mild) moves the cursor to the left in the message. Depressing switch "B" for less than one second will move the cursor right one character at a time. If depressed longer the rate of movement will speed up.

8. **CHARACTER FORWARD** -
Switch "C" (coffee strong) controls the characters at the cursor location. Depressing switch "C" for less than one second will move forward through the character set one character at a time. If depressed longer the rate of movement will speed up. When a character has been correctly set simply move on to the next character.
9. **CHARACTER REVERSE** -
Switch "D" (light medium) also controls the characters at the cursor location. Depressing switch "D" for less than one second will move backward through the character set one character at a time. If depressed longer the rate of movement will speed up.
10. The () character indicates the left and right boundaries of the user message.
11. The (¶) character must be entered to indicate the end of message to be displayed. Otherwise the display message would ignore the boundary character and may scroll some characters that do not belong to the character set.
12. The message program mode should be exited by depressing the mode switch only.
13. **VALID CHARACTER SET** -
The following characters are available:
A through Z
0 through 9
\$ ' < > * + , - . / ? ¶
A blank is represented by a flashing underline _

APPENDIX I - GRAM THROWS AND WATER VOLUMES

RECOMMENDED GRAM THROWS

	7oz	8.25oz	10oz	12oz
COFFEE	7-7.5	8-8.5	9.75-10.25	11.5-12.5
LIGHTENER	1.5-2	2-2.5	3.0-3.4	4±
SUGAR	5-5.5	6.5-7	6.8-7	9-10
FD COFFEE	1.2	1.5	1.8	2-2.5
FD TEA	1.2	1.5	1.8	2-2.5
FB TEA	2.5	3-3.25	4.0	4.5
SOUP	5-5.5	6-6.5	7.0	7.5±
CHOCOLATE	20-22	24-26	28-31	33-36
SGC	14-15	17-18	23-24	26±

◆ **454 GRAMS = ONE POUND**

Examine your ingredient package for ingredient amounts. Use product manufacturers recommendations for ingredient throws. All gram throws above are approximations.

Always take three test and average for best accuracy, except for products like chocolate where the product quantity exceeds scale capacity.

Some lightener is super fine and will bind up behind louvers in spout - solution is to remove louvers or replace spout.

Changing from "SANKA" to no name fd coffee louvers must be removed.

Soluble Gourmet Coffees MUST USE 180 RPM MOTOR to deliver sufficient product during the allotted time.

Zero scale before starting - nickel weighs exactly 5 grams

WATER VOLUME IN CUBIC CENTIMETERS V.S. CUP SIZE

Nominal size	7 OZ.	8.25 OZ.	9 OZ.	10 OZ.	12 OZ.
Volume to brim (cc)	205	235	270	290	345
PRACTICAL VOLUME FOR VENDING (cc's)					
COFFEE, BREWED/SOLUBLE	175	205	225	260	315
TEA - BREWED	175	205	225	260	315*
TEA - SOLUBLE	175	205	225	260	315
SOUP	175	205	225	260	315
CHOCOLATE - WHIPPED	150	175	190	220	270
SGC - WHIPPED	150	175	190	220	270

◆ * FB TEA 12 OZ. = 250cc from FB Tea Water valve + 65cc make up water
30 cc = 1 ounce liquid measure

APPENDIX II: 213 SWITCH NUMBERS

SELECTOR PANEL SWITCHES

Switch # Description

00 Selection 4, mild
01 Selection 4, regular
02 Selection 5, mild
03 Selection 1, mild
04 Selection 1, regular
05 Selection 1, strong
06 Selection 2, mild
07 Selection 2, regular
08 Selection 2, strong
09 Selection 4, strong
10 Selection 5, strong
11 Sugar, low
12 Sugar, medium
13 Sugar sub, low
14 White, low
15 White, medium
16 White, high
17 Sugar, high
18 Sugar sub, high
19 Selection 7, chocolate
20 Selection 5, regular
21 Selection 6, soup/SGC
22 Sugar sub, medium
23 Right START
24 Cancel
29 Selection 3, mild
31 Left START
38 Selection 3, regular
41 Selection 3, strong

Switch # Description

25 Discount switch
26 AutoFlush enable interlock
27 Waste and grounds bucket-AC Present
28 Cup Sensor input (N.O.)
30 Mode
32 Security key
33 Brewer water enable switch
34 Brewer cycle
35 Brewer delay enable switch
36 Heater thermostat #1
37 Heater thermostat #2
40 Water present - Probe
46 Cup present switch #1
47 Cup present switch #2

APPENDIX III: "OUT OF ORDER" CODES

The "OUT OF ORDER" codes that appear in the scrolling display indicate which of the conditions are causing the machine to be out of service. The codes are additive and may indicate that more than one condition exists. **EXAMPLE:** Code M22 equals M20 plus M02: this would indicate that one of the bucket floats has deactivated its switch and the water level in the tank is low. Both conditions must be corrected before the machine will return to service.

Code	Out of Cups M01	No Water M02	EPROM Mismatch M10	No AC (Float high) M20
M01	Out of cups			
M02		No Water		
M03	Out of cups	No Water		
M10			EPROM Mismatch	
M11	Out of cups		EPROM Mismatch	
M12		No Water	EPROM Mismatch	
M13	Out of cups	No Water	EPROM Mismatch	
M20				No AC (Float high)
M21	Out of cups			No AC (Float high)
M22		No Water		No AC (Float high)
M23	Out of cups	No Water		No AC (Float high)
M30			EPROM Mismatch	No AC (Float high)
M31	Out of cups		EPROM Mismatch	No AC (Float high)
M32		No Water	EPROM Mismatch	No AC (Float high)
M33	Out of cups	No Water	EPROM Mismatch	No AC (Float high)

NOTE: If a code other than one of the above shows in the scrolling display, MODE 11 is probably configured incorrectly and should be checked immediately. The only way to eliminate an M10 code is to perform a Mode 16 reset - see page 2.13.



CAUTION: THE FOLLOWING PROCEDURES REQUIRES THAT THE MACHINE HAVE POWER APPLIED AND A POTENTIAL ELECTRIC SHOCK HAZARD EXISTS

SERVICE INDEX

SANITIZING AND CLEANING PROCEDURES	3.01
PREVENTIVE MAINTENANCE SCHEDULE	3.02
FUNCTION OF THE BREWER	3.03
ADJUSTMENT OF THE BREW CABLE	3.06
WATER SYSTEM	3.08
WATER DELIVERY SYSTEM	3.09
THE CANISTER RACK	3.10
CUP DELIVERY SYSTEM	3.11
CUP DISPENSER ADJUSTMENTS & CHECKS	3.13
LARGE GRINDER	3.16
ZERO ADJUSTMENT FOR THE LARGE GRINDER	3.17
ZERO ADJUSTMENT FOR THE MINI-GRINDER	3.18
TROUBLESHOOTING	3.20
213 TROUBLESHOOTING CHART	3.22
LOGIC BOARD REPLACEMENT	3.28
MOTOR CONTROL BOARD PIN CONNECTIONS	3.29
LOGIC CONTROL BOARD PIN CONNECTIONS	3.30
SCHEMATIC - VERSION E SOFTWARE	3.31



CAUTION - VERY HOT WATER: USE EXTREME CARE WHEN REMOVING FROM THE TANK WHEN USING THE RINSE HOSE OR DRAIN. WATER IS HOT ENOUGH TO CAUSE PERSONAL INJURY.

SANITIZING AND CLEANING PROCEDURES FOR AP 213

EACH VISIT

1. Fill cup cabinet with cups to required level. Wipe interior and exterior of cup cabinet.
2. Replenish all canisters and/or bean hoppers. Clean any spills. Wipe the lids of the canisters with a damp towel. Dry all damp surfaces.
3. Run the flush cycle (MODE 3) which will take approximately 1 ½ minutes. Depress the mode switch until the display indicates "MODE 03". Depress the START front panel switch. The machine will then show "OPT Y/N". Use the coffee strong button to change the Y to flashing. Depress the START front panel switch. The machine will then start a series of flush cycles.
4. After the completion of the flush cycle, cycle brewer to the dump position by depressing the front left roller switch on the brewer until the brewer will continue to run on it's own. When the brewer reaches the forward position, turn off the control circuit breaker. Remove the splash guard from the front of the brewer. Using the spray hose, rinse any loose grounds from the brewer and the splash guard. Replace splash guard and restore power to machine.
5. Remove the humidity bar (CAUTION-bar is hot) and the commodity chutes from the trough. Check all canister spouts and commodity chutes for blockages. Rinse commodity chutes and trough with spray hose to remove any residue. If necessary the trough can be scrubbed with a damp cloth followed with a rinse of hot water from the spray hose. **DO NOT SCOUR THE TROUGH WITH ANY ABRASIVE MATERIAL!** This can result in a poor wash of the trough and poorly mixed ingredients in a drink, or residue in the trough. Carefully dry the

commodity chutes and reinstall the humidity bar and the commodity chutes.

6. Using warm water and detergent clean other interior surfaces, wipe with a damp cloth and wipe dry.
7. Remove cupwell, grate and vend door, clean with hot water and detergent. Rinse with clear water and dry with clean cloth or paper towel. Wipe inside of door and clean vend door guides. Replace cupwell, grate and vend door in machine.
8. Remove disposable bag containing spent coffee grounds and rinse bucket with hot water and replace liner. Empty and scrub waste bucket. Rinse with anti-bacterial solution. DO NOT rinse bucket after anti-bacterial solution is used- this will defeat its purpose. Clean floor of machine with hot water and wipe dry. Replace buckets in machine making sure both floats are hanging free in the buckets.
9. Before closing door access **MODE 2** and press **START** to set one test vend to check for proper operation. Lock vendor door, make a selection, clean exterior of door and cabinet.

QUARTERLY



CAUTION: THE BELOW PROCEDURE SHOULD BE PERFORMED BY A QUALIFIED PERSON TRAINED IN PREVENTIVE MAINTENANCE!

1. Cycle brewer to the 'dump' position, spray with rinse hose to remove any excessive grounds. Disconnect the brewer cable from the carriage by gently pushing the carriage to the rear and lifting the cable out of its slot. Lift the lower brewer assembly latch and remove the bottom half of the brewer. Place in a bucket of hot water to allow it to soak.
2. Remove steam duct, exhaust hose, and metal screen between exhaust motor and mounting plate. Rinse clean with hot water. Dry with a clean cloth and return to position.
3. Disassemble chocolate whipper housing and mixing bowl by spreading the wire clips and pulling straight out. Clean parts with hot water. Clean and inspect the whipper base and impeller for wear. Reassemble making sure the large 'O' ring is positioned correctly inside the whipper housing.
4. Disconnect all hoses from mixing bowls, channel and delivery spout and clean with hot water. Replace hoses.
5. Remove lower half of brewer from bucket and rinse well with hot water and install on main brewer assembly. Reconnect cable. Inspect brew filter, screen and gasket for wear, rips or obstruction of the filter or screen.
6. Remove cover of coffee delivery chute and clean chute and cover with a dry cloth. Replace cover.
7. Clean coin mechanism acceptor with a damp cloth and wipe dry.
8. Perform **EACH VISIT** procedure above.

PREVENTATIVE MAINTENANCE SCHEDULE

for API Hot Beverage Merchandiser

SERVICE AT EACH INTERVAL LISTED X MONTHS OR VENDS WHICHEVER COMES FIRST	1	4	8	12	24	36
BREWERS						
Filter screen, Coffee Brewer	Clean	Inspect	Replace			
Seal, Brew Chamber (Black)	Clean	Inspect				
Seal Ring, brew Filter Screen		Inspect				
Wiper Blade, Carriage		Inspect		Replace		
Brewer Carriage, Rods, Springs	Clean	Inspect		Lubricate		
Lubricate Brewer				Lubricate		
PRODUCT DELIVERY SYSTEM						
Mixing Troughs & Bowls	Clean					Replace
Whippers	Clean					Inspect
Exhaust System: Hose, Duct Screen	Clean	Inspect				
Liquids delivery hoses	Clean		Replace			
Coffee delivery chutes	Clean					
Grinder coupling				Inspect		
Tea Brewer Filter	Clean	Replace				
MISCELLANEOUS						
Water Inlet Filter Cartridge				Replace		
Water Valves On Water Tank					Inspect	Rebuild
Coin Mech	Clean	Inspect				
Water Tank Interior				Inspect		Clean

THIS SCHEDULE SHOULD BE FOLLOWED IN ADDITION TO THE "EACH VISIT" CLEANING RECOMMENDED IN THE SERVICE SECTION OF THIS MANUAL.

CLEAN =Clean and sanitize per NAMA procedures

INSPECT =Inspect for wear, product built up or broken part. After inspection- repair, adjust, clean, rebuild or replace.

REPLACE =Recommended interval for replacement

REBUILD =Remove from machine, take apart, clean and replace worn or corroded parts.

LUBRICATE =Should be cleaned, inspected, and repaired before lubrication. Recommended lubricate is a food grade, light weight oil brand.

FUNCTION OF THE BREWER IN AN AP 213

The heart of the AP 213 Hot Drink Merchandiser is the 12 ounce open cylinder brewer. It has been "time proven" and "experience improved". It is simple, lightweight, easy to clean and easy to service. The major improvements to the 12 ounce brewer that have been incorporated are:

- Increasing the size of the brew cylinder to accommodate multiple volumes of liquid up to and including 12 ounces of liquid.
- A newly designed brewer base assembly that reduces the number of moving parts by replacing the movable filter and its associated parts with a fixed filter. This change will reduce service calls by eliminating the necessity to replace broken part and in testing has allowed the brewer to operate cleaner.

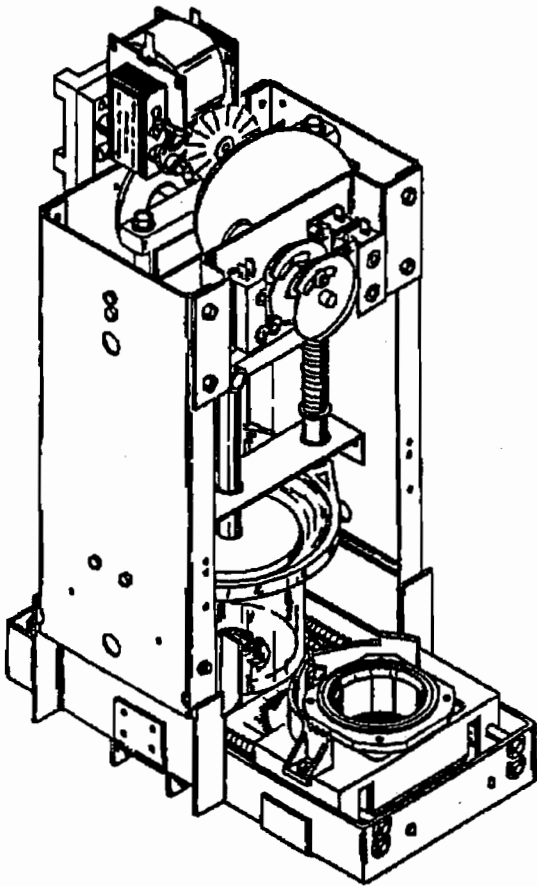

FIGURE 3.1

HOW THE BREWER WORKS

The word "front" used in this description refers to the parts of the brewer nearest the observer, standing before the open cabinet.

All AP 213 fresh brew machines have the brewer stopping at the same point. The brewer is stopped with the brew carriage aligned directly over the platform of the fixed brew filter and under the coffee delivery chute. When a brewed coffee drink is selected, the ground coffee (from a grinder or an LG canister) is delivered directly to the brew chamber via the stainless coffee delivery chute.

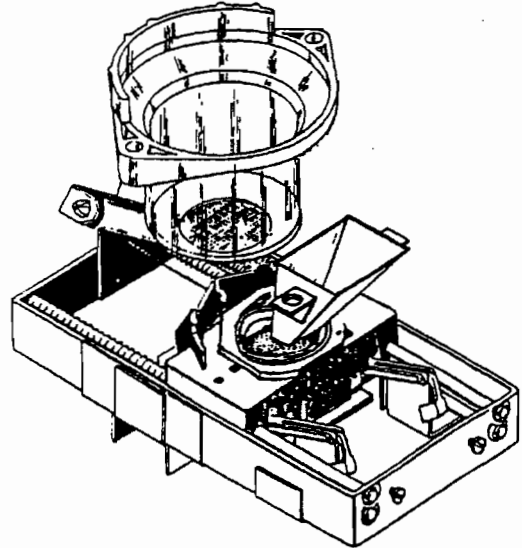

FIGURE 3.2

The brewer starts at the time determined by channel 7 (typically 4.00 seconds). When the brewer starts, the cable will begin to retract the brew carriage towards the rear of the base assembly. Once the left front switch (brewer cycle) rides up on the high side of the front cam, the brewer will continue to run until this switch falls back into the valley.

The brew carriage will continue back until it is slightly behind the clear brew cylinder. When the brew cylinder starts its downward motion, the cable is slackened slightly to allow the brew carriage to move forward, and by use of an alignment shoulder, self-align with the cylinder. As the cylinder clamps down on the brew chamber seal, the roller of the single switch (brew water enable) on the right side falls into the valley of the cam and the switch will send a signal to the logic board that now is the proper time to deliver water to the brewer. The brew water valve is energized for the duration determined by channel 8. Immediately after the water valve opens, the left rear switch (delay switch) rides up on the high side of its cam. This switch changing position signals the logic board to activate the delay set in channel 9. This delay, named the open cylinder delay, de-energizes the brewer motor and allows

all required brew water to be delivered into the cylinder. Once the open cylinder delay is complete, power is restored to the brew motor and the cycle continues. This delay is also added to the light and sugar motor start times to compensate for the delayed delivery of the coffee to the trough. The cylinder is held tightly against the brew chamber seal by the springs on the cylinder support rods. The brew water enable switch will also signal the logic board just before the piston has contacted the cylinder to indicate that the window for delivery of brew water has passed. The water will flow into the cylinder down through the grate in the bottom of the cylinder into the coffee filled brew chamber. The grate in the bottom of the cylinder prevents the coffee grounds from floating up into the cylinder.

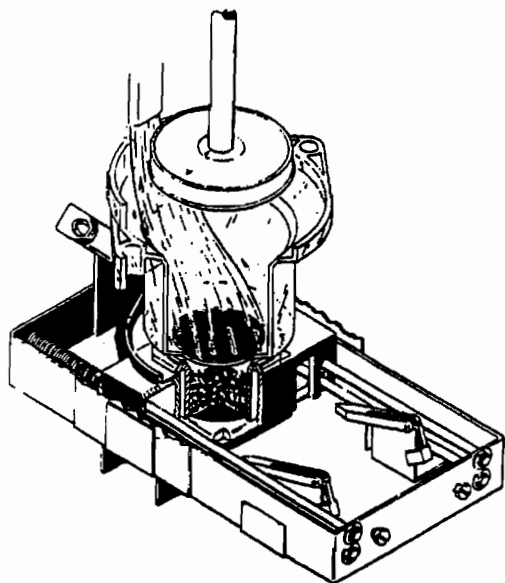

FIGURE 3.3

As the cycle continues, the piston is moved down into the cylinder by the largest cam on the main shaft. Air trapped between the piston and the water in the cylinder is quickly heated by the hot water and begins to expand. The downward motion of the piston, plus the pressure of the expanding air, forces the water through the coffee grounds in the brew chamber and out through the delivery funnel to the trough.

The heated, compressed air follows the water through the grounds forcing the remaining water out of the grounds and drying the grounds. When the roller of the third switch falls off the high side of the rear cam, the delay switch will signal the logic board to activate the pressure relief delay for the duration set in channel 10.

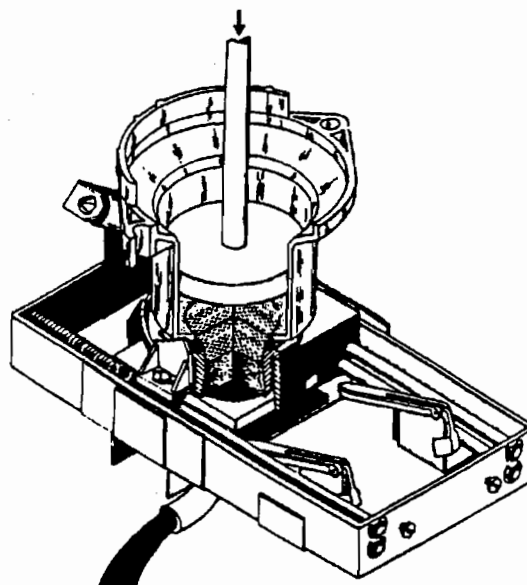

FIGURE 3.4

This pressure relief delay allows any built-up back pressure in the brew chamber and cylinder to dissipate through the bed of grounds and prevent grounds under pressure from escaping and being deposited on sealing surfaces.

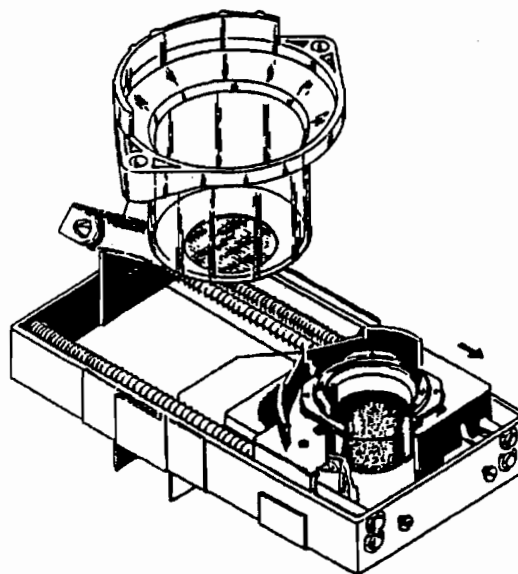

FIGURE 3.5

After the pressure relief delay, the brewer starts the portion of the cycle that empties the brewer of spent grounds and resets the brewer for the next vend. The brew carriage cable is tightened and the piston and cylinder are raised far enough to allow the brew carriage to pass under the cylinder.

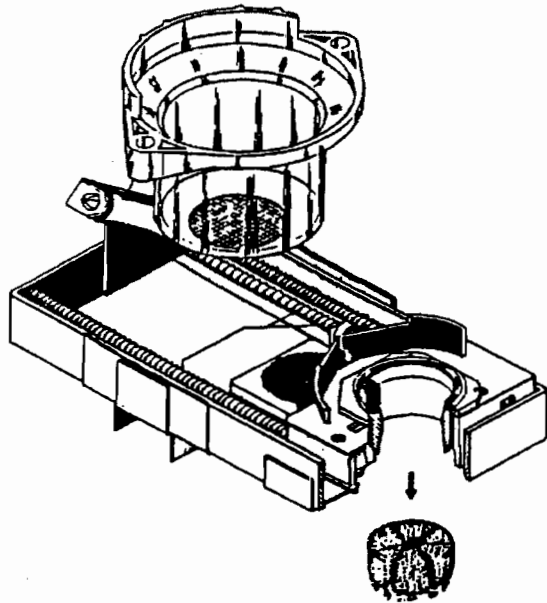

FIGURE 3.6

The cable is then unwound, controlling the forward motion of the brew carriage, which is being forced forward by the carriage rod springs. As the brew carriage passes over the two white pawls in the base assembly, the two ears on the sides of brew chamber lift the brew chamber allowing the brew chamber to ride up the pawls. As soon as the ears are free of the support of the pawls, the brew chamber snaps downward, dislodging the spent grounds into the grounds bucket. A large wiper blade fixed to the underside of the brew carriage, completely cleans the surface of the fixed filter assembly, as the carriage moves forward to the dump position.

The cable will then begin to retract the brew carriage toward the rear of the base assembly until the brew chamber is directly over the filter and under the delivery chute. At this point the roller of the brewer cycle switch will fall into the valley of the front cam, signaling the logic board to stop the brewer. This is the standby position and the brewer will remain in this position awaiting the next vend.

FIXED FILTER BREW BASE

The fixed filter brew base improves on the previous designs of the brew base by reducing the number of moving parts, thereby reducing the number of service calls. The primary difference between the fixed filter brew base and previous brew bases, is that the lower set of rods and springs that the brew filter rode on, have been eliminated. The previous filter, filter support, funnel cover, rods and springs, and delivery funnel have been replaced by a fixed filter, screen and gasket and a new $\frac{1}{4}$ turn delivery funnel. Aside from the reduction in moving parts and lower maintenance costs, one of the added benefits of the fixed filter brew base is that it operates cleaner. This is partly due to the wider, stiffer wiper blade under the carriage that cleans the surface of the filter during each cycle, and the wide flat bed of grounds that help eliminate any pressure buildup which guarantees the used grounds are dry and easily ejected from the brewer. Because of the fewer moving parts, and fewer welded parts, it is easier than ever to clean the brew base completely during routine service of the machine. While the brewer is in the brewing position, it is possible to clean the metal base on either side of the filter with a thin brush.

The entire brew base frame has also had the number of separate metal parts reduced, partly to ease in manufacturing, but also to improve the accuracy of the brew base frame so its maintenance costs are as low as possible. The previous base frame had a total of 8 welded parts, the fixed filter base has reduced it to 6.

The fixed filter is mounted onto the brew base assembly by three tabs - one each on the left and right, similar to the standard brew filter, but also has a locking tab on the front that holds the platform on the front of the filter firmly in place. The filter is installed on the base by pressing the screen and gasket into the filter, and then holding the filter assembly with the front platform down, and inserting the front tab into its slot. The left and right tabs can then be snapped into place to secure the filter in place. The rear of the filter is square, while the front of the filter is a half circle that matches the outline of the base of the circular brew chamber. The surface of the filter and platform are squeegeed clean twice during the vend cycle by an oversize wiper blade mounted in the bottom of the carriage. This wiper sweeps the entire surface of the filter. The gasket and screen located under the filter are identical to the current parts used in the 12 ounce brewer. The coffee delivery funnel is a new design which mounts directly to the bottom support cross bar with four tabs that fit through corresponding notches and is then turned $\frac{1}{4}$ of a turn to lock the funnel in place.

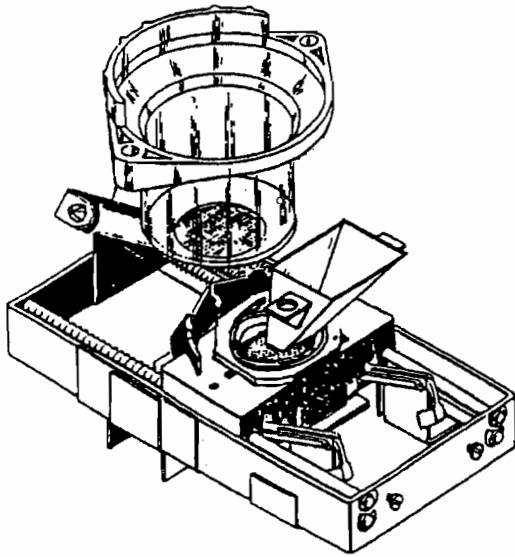

FIGURE 3.7

BREW CARRIAGE AND CABLE ADJUSTMENT

The horizontal movement of the carriage is caused by the springs in the base assembly. The action of the springs is controlled by the brew carriage cable assembly. The cable is wrapped on a spool and wound and unwound to move the carriage in synchronization with the other movements of the brewer. The cable spool is controlled by a gear segment driven by the rear cam of the main shaft assembly. The shape of the cam determines when the cable is wound and unwound.

When the cylinder is pressing down on the brew chamber, the cable should be slack. Just as the brew cylinder begins to raise the cable tightens, to prevent the carriage from jumping forward as the cylinder clears the alignment shoulder of the brew carriage. As soon as the cylinder is high enough to clear the carriage, the cable is unwound and the carriage moves forward to dump the spent grounds. After the spent grounds are dumped, the cable again winds on the outer spool and pulls the carriage to the stopping position.

The cable is attached to the outer section of the spool with a cotter pin. The inner portion of the spool is connected to a shaft and a small gear. The gear is rotated by a pivoting segment gear driven by a cam follower riding on the edge of the rear cam of the main shaft assembly. The inner and outer sections of the cable spool have matching teeth which provide a positive mesh but allow for adjustment. When the two parts are assembled, they are secured by a screw and washer which prevent them from being disengaged.

ADJUSTMENT OF THE BREW CABLE

Operate the brewer through a complete cycle and observe that:

- A. The alignment shoulder of the carriage is slightly behind the rear vertical edge of the brew cylinder as the cylinder starts down and,

- B. As the carriage is drawn back behind the cylinder, that the carriage springs retain a small amount of wave (not compressed to their minimum length) and
- C. After brewing, the carriage moves forward evenly and gradually to the dump position.

If all three of these conditions are not met, then a cable adjustment should be made using the following procedure:

1. Depress the front left switch on the top of the brewer and allow the brewer to cycle to the brew position. Turn off power and lift the latch pin in right rear of the brewer and swing the brewer away from the water tank.

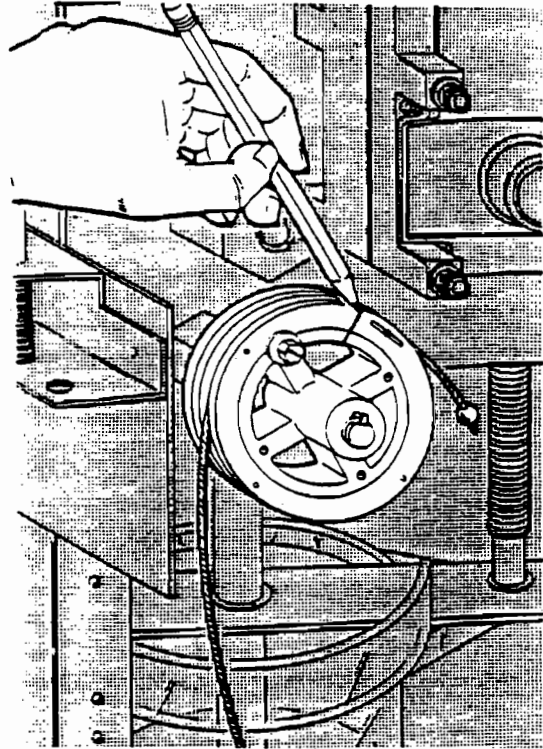

FIGURE 3.8

2. Mark the inner and outer section of the cable spool with a pencil line across both pieces to provide a reference mark. See FIGURE 3.8.
3. Restore power and cycle the brewer to the dump position and turn off the power.
4. If the carriage was not correctly behind the cylinder and is being forced back out of the way or the cylinder is resting on top of the alignment shoulder of the brew carriage (see FIGURE 3.9) and causing the brew water to leak from between the cylinder and the brew chamber, then an adjustment of only one or two teeth to shorten the cable is needed - go to step 9. If the original adjustment has been lost, then a 'scratch' adjustment will have to be made - continue to step 5.

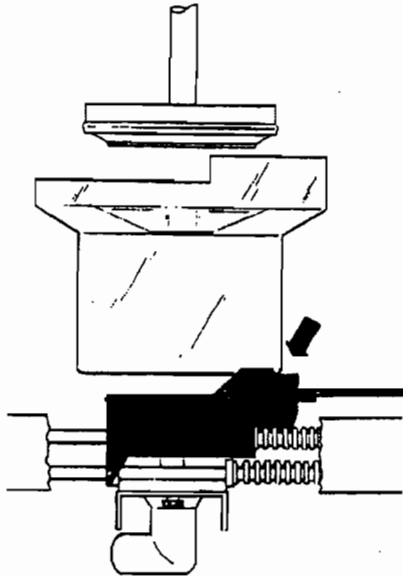

FIGURE 3.9

5. Confirm that the cam follower is in the deepest valley of the rear cam (See Figure 3.11) by cycling the brewer to this position. This position of the cam and follower guarantees that the brewer is in the dump position.
6. Feed the cable down between the roller and the support bracket and towards the front of the brewer. Slip the cable into the slot on the rear of the carriage.
7. Wind the cable clockwise on the outer spool until the carriage is pulled back from the inner face of the base assembly (See Figure 3.10) 1/8 to 3/16 inch.

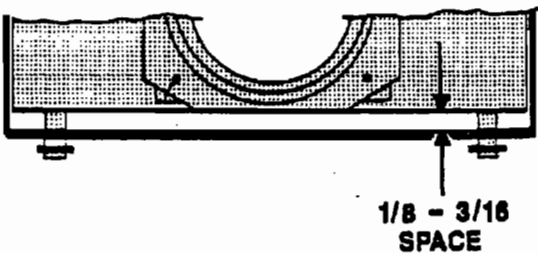

FIGURE 3.10

8. While holding the follower in the valley of the cam, (see FIGURE 3.11) install the outer section of the cable spool over the inner section. Release the follower and spool and check that the clearance set above is maintained. If so, make a new reference mark across the spool and remove the outer section of the spool and rotate it counter-clockwise one tooth-skip to Step 10.

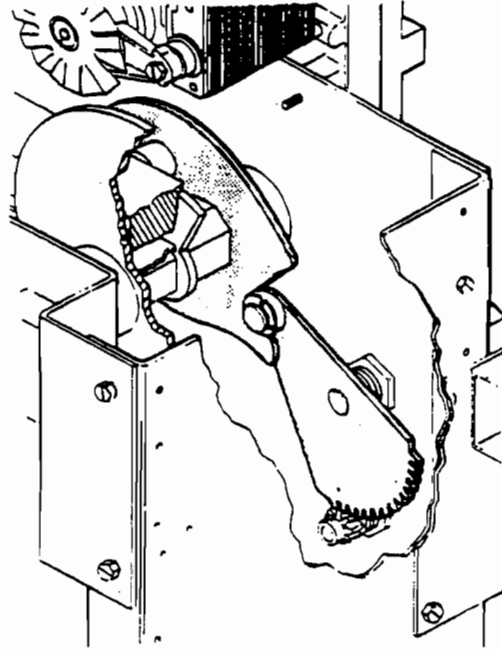

FIGURE 3.11

9. Carefully pull the outer section of the cable spool off and rotate it one tooth clockwise to tighten the cable and replace the outer spool.
10. Restore power and cycle the brewer again, watching for the three conditions above.
11. If the carriage is still not being drawn back far enough during the cycle, repeat Step 9.
12. After ensuring that the cable is adjusted correctly, replace the screw and washer that secure the two halves of the cable spool and cycle the brewer to the brewing position and turn off the power. Swing the brewer closed and ensure that the latch pin drops into place. Restore power and test vend.

WATER SYSTEM

The water system is a gravity system (thus requiring no pumps or compressors) with an open air break at the tank inlet required by most local codes. The temperature control will maintain the water temperature near the boiling point. Coffee extraction requires hot water as close to boiling as possible. The thermostatic control system has been time proven as a very dependable, yet simple control method.

THE WATER TANK

The water tank is constructed of stainless steel with a welded internal baffle and holds approximately five gallons of water.

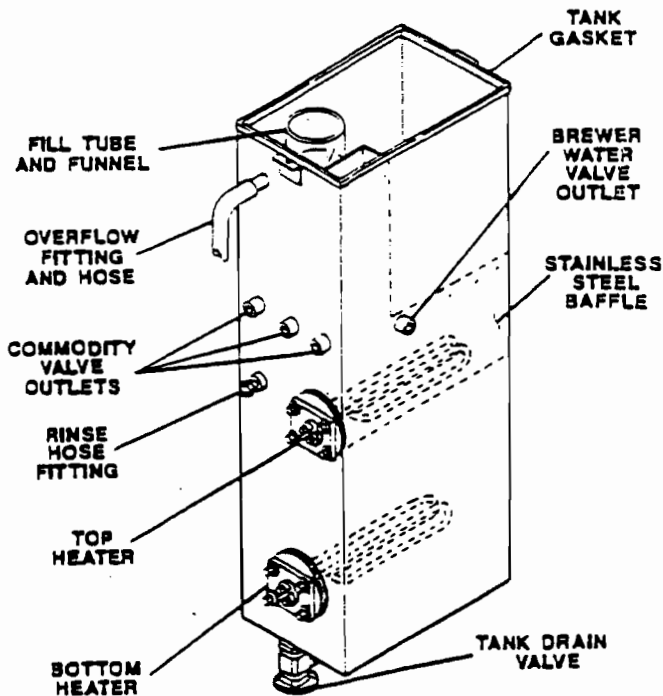

FIGURE 3.12

It has a removable lid that is sealed at the top of the tank with a gasket. The tank has two 1500 Watt heaters that are on a priority system, controlled by the thermostats mounted on the tank lid. The stainless steel baffle in the tank surrounding the top heater and brew water outlet fitting provides the hottest water in the tank at the brewer water valve outlet. This ensures continuous hot water for brewing coffee.

WATER INTAKE SYSTEM

There are two possible configurations in the intake system. The most common method provides for a water filter to be installed as a part of the original equipment. The filter housing includes a shut-off valve and twist-to-release filter head that accepts a cartridge type water filter. A less common method is a straight copper tube with a shut-off valve between the inlet fitting and the water inlet valve.

The water inlet valve provides the method for controlling the intake of water into the water tank. This valve is also part of the sold out circuit. If one of the safety overflow switches in the liquid waste or used grounds bucket is activated (raised), the valve's supply voltage is disabled and will not allow water into the water tank. Also, if the water inlet valve remains on for more than 90 seconds, the logic board will disable the valve until power is disrupted and restored.

THERMOSTATIC CONTROL SYSTEM

The thermostatic control system consist of two identically rated thermodiscs located on the lid of the tank. The standard fresh brew thermostat is rated at 190°F, and the thermostat for a freeze-dried machine is 180°F. The top heater is controlled by the thermostat mounted on the left front corner of the tank lid, and has priority over the bottom heater and thermostat. The front thermostat senses the temperature of the water via a sensor that extends down inside the baffle of the tank. The bottom heater thermostat is mounted in the center of the tank lid. When the top heater thermostat is satisfied, it will allow the bottom heater to come on and finish heating the entire tank. Except in cases of a heavy draw the bottom heater will maintain the correct temperature in the tank. A jumper plug, located in the harness, directly above the water tank, provides a logic control circuit to monitor machine conditions. This jumper wire connects two former logic level thermostat wires to provide a constant 110 volts at the P8-2 and P8-3 terminals on the motor control board. This constant voltage is supplied to the Common (center) terminal of the front thermostat and directs the voltage to the top heater or the rear thermostat dependent upon the temperature of the water in the tank. This allows direct control of the heater elements by the thermostats.

ELECTRONIC LIQUID LEVEL CONTROL

All Model 213 use an Electronic Liquid Level Control (ELLC). The probe is connected to P7 on the logic board. The ELLC performs three functions. Its primary function is to monitor the level of water in the tank and replenish the tank as needed during normal operation. The switch's other functions are helping the logic board monitor the condition of the inlet water system and the operation of the heaters. If the logic board senses that the probe circuit calls for water for 90 seconds, it disables the water inlet valve and turns off the heaters. Also, the logic board will not allow the heaters to turn on upon power being applied to the merchandiser until the probe has been satisfied once. Therefore it is important NOT to ground the probe while the tank is filling as this will cause the heaters to turn on before the tank is full and may cause damage to internal components of the tank.

◆ If it is necessary to ground the probe during a "dry" set-up of the machine, disconnect the probe harness from the main harness before touching the probe assembly. Possible electrostatic damage may occur if the probe is touched while connected to the circuit!

WATER DELIVERY SYSTEM

A maximum of five valves compromise the water delivery system. They are: the Coffee Brew Water Valve, the Chocolate Water Valve, the FD Coffee/Tea Water Valve, the Fresh Brew Tea Water Valve, and the Soup/Soluble Gourmet Coffee Water Valve. Each of these valves will release water into its particular segment of the commodity mixing channels, depending on the beverage selected. The rear valve is located higher than the other two, allowing for the addition of a manifold and additional valve to be installed in the case of fresh brewed tea or multiple Soluble Gourmet Coffees.

- ◆ **IMPORTANT:** IT IS HIGHLY RECOMMENDED THAT THE WATER VALVES ON THE HOT WATER TANK BE INSPECTED AND/OR REBUILT EVERY TWO YEARS (SEE PREVENTIVE MAINTENANCE SCHEDULE ON PAGE 4.02). THE WATER CONDITIONS GOING TO MACHINE CAN CAUSE THE INTERNAL PARTS OF THE VALVE TO MALFUNCTION IF EXPOSED TO EXCESSIVE MINERAL BUILD UP. THE DIAGRAM CAN DETERIORATE AND LEAK WATER.

THE COFFEE BREW WATER VALVE

This valve is mounted on the face of the water tank directly behind the brewer. The valve outlet in the tank is contained within the stainless steel tank baffle along with the top heater. This allows the hottest water in the tank to be released through this valve and into the brewer. This valve is controlled by channel 8. There is no flow control available on this valve, as its purpose is to deliver water as quickly as possible to the brewer.

TEA, SOUP, FRESH BREW TEA AND CHOCOLATE VALVES

These valves are mounted on the left side of the water tank. Separate valves are essential because each beverage may require a different amount of water to brew the beverage properly, and each beverage is made and released from the machine through its own channels to avoid taste contamination. Each valve is controlled by at least one separate time channel on the logic board. Each of these valves is connected to the commodity rack by a flexible tube. The chocolate valve is positioned such that it can be removed and added to a manifold when a fourth valve is required for fresh brewed tea. Additional wires are included in the harness for use with a fresh tea brewer.

RINSE HOSE

A convenience feature is the rinse hose. This is provided for maintaining proper machine sanitation. It is long enough to reach each part of the machine which will normally require cleaning. To avoid any possibility of this hose leaking, a storage bracket has been provided, which holds the outlet of the hose above the normal water level in the tank.

OVERFLOW HOSE

Mounted in the upper left rear of the water tank is the overflow fitting. Should the water level in the tank rise too high, regardless of the reason, the excess will run out of the fitting, through the overflow tubing and directly to the liquid waste bucket. There should be no kinks or low spots in this hose.

OVERFLOW SAFETY

If the overflow condition continues the level in the waste pail will rise and eventually raise the float of the safety overflow switch shutting the water inlet valves and placing the machine on a "OUT OF ORDER M20" status. When "OUT OF ORDER", any coins inserted will be returned. All 110 volt functions from the motor control board will also be disabled.

OVER TEMPERATURE SAFETY THERMOSTAT

A 150°F manually resettable OVER TEMPERATURE safety thermostat is inserted in the overflow hose above the canister rack. This safety thermostat senses any boiling condition that exceeds approximately 4 minutes and disables the heater circuit by opening the neutral side of the line.

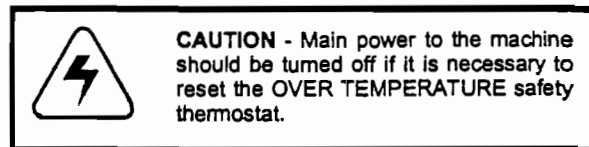

The thermostat is reset by pressing the small button in the center with a pencil eraser or similar non conductive object.

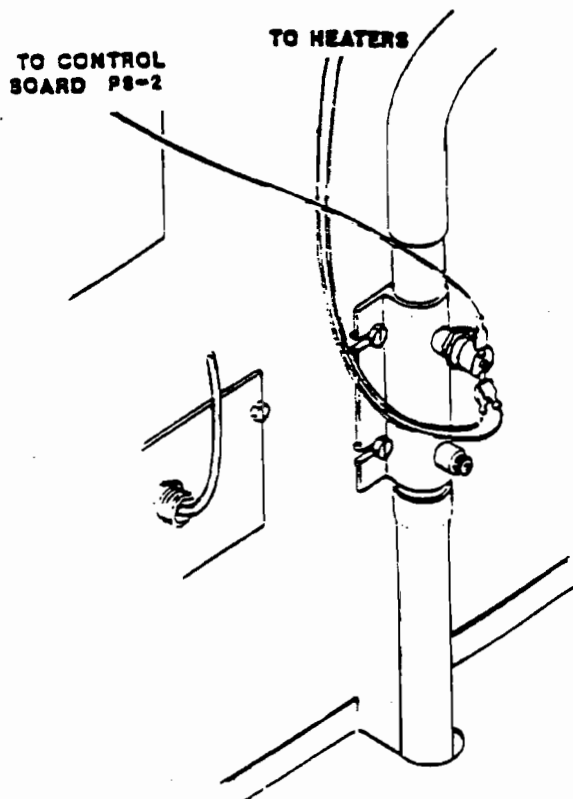

FIGURE 3.13

THE CANISTER RACK

The support for the entire dry product commodity system is of open construction design, with a minimum of horizontal surfaces to catch dust and spillage. The motors which drive the canister augers are all located behind and under the steel cover. Each motor may be removed, if necessary, by loosening four screws and lifting it out. Water tubes, to direct the water to the mixing channel and whipper are stainless steel and permanently attached to assure proper alignment.

COMMODITY SYSTEM

Containers for the dry product which the hot beverages machine dispenses are made of rugged translucent plastic. They are designed to dispense products on a first-in-first-out basis in order to insure a fresh product at all times.

The auguring system used to dispense the products runs in reinforced nylon bearings to assure long trouble-free life. The dispensing end of the canister may have a louvered spout. These louvers control the accuracy of discharge so that the proper mixing is assured for each drink. The translucent materials permit the service person to estimate the contents of the canister without having to open the canister. Commodity levels may be marked on the outside of the canister so that the service person can easily refill them to a pre-determined level. This type of control will reduce product waste and assure commodity freshness by the elimination of overfilling.

THE HUMIDITY BAR

The humidity bar is a vital part of the commodity system. It is electrically heated and by providing a slightly higher temperature at the canister outlet spouts will prevent moisture from being absorbed by the dry products. If the machine is operated in a humid atmosphere without the humidity bar in operation, it is likely that the dry products will cake and not dispense properly. The tabs on the humidity bar fit into their respective slots in the commodity rack between the canisters. The humidity bar plugs into a harness on the left side of the cabinet.

THE DUAL STEAM EXHAUST SYSTEM

Due to the increased volume of steam from vending larger drinks, the Steam Exhaust System has been improved by adding a second outlet to the exhaust duct on the rear of the canister rack, along with a second hose and dual plenum on the exhaust motor. Steam from the hot water needed to make the beverages is controlled by this system. Uncontrolled steam in a vending machine will create severe problems through caking and hardening of the dry products. Such a condition will prevent proper dispensing. By moving low velocity air, in high volume through the areas where steam is generated, the steam is removed before it can reach the dry product dispensers. The air is moved by a squirrel cage blower, and discharges outside the machine cabinet. The steam is generated whenever the machine is activated to dispense a beverage. The hot water used to make coffee, tea or soup, passes through the main mixing channel as the dry products are dropped. Immediately adjacent to the mixing channel is a dual outlet vacuum duct which is connected to the blower by a pair of reinforced plastic hoses. Directly over the mixing channel is the steam deflector and commodity chute. Lightener, sugar, tea and soup products are dropped into the moving liquid in the mixing channel directly from their respective canisters. The design of this deflector is such that a constant stream of dry air is pulled down through the commodity chutes of the deflector and actually helps delivery

of the product to the mixing channel. At the same time, this deflector effectively prevents the steam vapor from rising in the area of the commodity canister outlets.

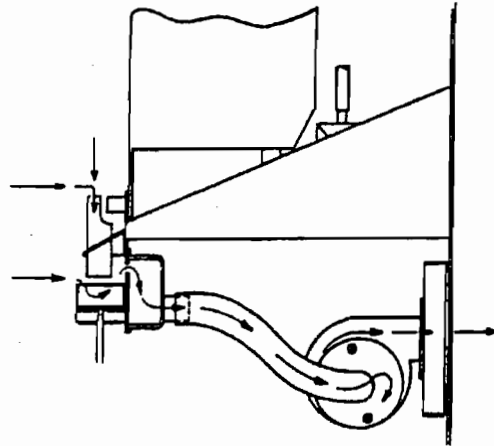

FIGURE 3.14

STEAM EXHAUST FLOW

The components of the steam exhaust system: the mixing channel, the steam deflector, the steam duct, the hoses to the blower, and the metal screen behind the exhaust fan assembly are all easily removed for cleaning. Cleaning is easily accomplished by rinsing in hot water. The mixing channel itself, which carries the beverage, should be sanitized according to the current industry practices.

CHOCOLATE WHIPPER

The chocolate beverage is thoroughly mixed and made more attractive to the user by whipping it as it is delivered. There is a separate mixing system for chocolate. It does not pass through the same mixing system as coffee or other beverages. As soon as the water for chocolate is released the whipper motor, which runs at high speed, starts. The chocolate powder is dropped from its canister directly into the water in the mixing bowl and flows into the whipper chamber and then to the cup. The whipper parts are all of a food service approved plastic material, highly resistant to mechanical damage. They are easily removed, without tools, for sanitization. The assembly is held together by spring clips.

REMOVAL OF STEAM EXHAUST DUCT

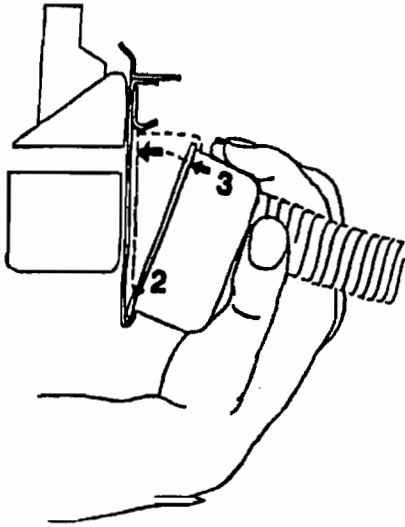

FIGURE 3.15

1. To remove the steam exhaust duct, pull the top down away from the front plate of the canister rack and lift from the bottom flange.
2. To install the steam exhaust duct, place the bottom lip of the duct on the bottom flange of the canister rack, behind the front plate.
3. Rotate the top of the exhaust duct toward the back of the front plate of the rack until it snaps securely in place.
4. Looking at the front of the rack, slide the duct left or right until the slots in the front plate properly line up with the ends of the exhaust duct.

MIXING CHANNEL AND ACCESSORIES

The use of specialty products may require the use of higher speed motors and/or additional whippers. Kits exist for the installation of additional whippers under the outlet of mixing bowls and each of the configurations of the mixing channels.

FRESH TEA BREWER

The AP 213 also has the capability to deliver a cup of fresh brewed tea. Certain canister rack configuration may prohibit the use of fresh brewed tea. Currently, this capability requires adding a manifold and a valve because the tea brewer requires a separate water valve. The tea brewer assembly consists of three basic parts: the canister and auger motor assembly, the tea brewer and the spent tea chute and drip tray. The entire assembly occupies the extreme right position on the canister rack. The canister and motor assembly are secured to the top of the rear shelf of the canister rack by one fixed clamp that allows for easy removal. The brewer and drip tray snap into the canister rack using the same locating tabs as a normal canister. The spent tea chute clips into the front of the brewer and guides the spent leaves to a second bucket for disposal. All wiring for the tea brewer is already included in the merchandiser and consists of a 6 pin plug which is placed in a rectangular hole in the rear face of the canister rack and the two wires for the canister motor are fed up through the top shelf of the canister rack.

The tea brewer has a simple gravity fed, open brew chamber,

similar in operation to the coffee brewer, except that no piston is used. A fresh brewed tea selection, once selected, begins with the canister motor auguring a small quantity of leaf tea (approximately 3 grams for an 8 1/4 oz. drink) into the open brew chamber. The separate brewed tea water valve then opens and delivers the water to the brew chamber via a tube mounted on the side of the canister motor mounting bracket. Best results are achieved by reducing the flow of the water by adjusting the metering screw on the valve to stretch the water flow out over the longest time possible. This allows the water and tea to steep for as long as possible before the brewed tea liquid flows out the delivery spout and into the mixing channel where lightener and sugar can be added. The lightener and sugar are controlled by separate channels. The tea leaves are prevented from following the liquid by a fine mesh filter that also acts as the bottom of the brew chamber. After the liquid has seeped through the tea, the brewer cycle switch receives a start pulse from the motor control board and starts the brewer motor and its crank arm into the dump cycle. The crank arm moves the brew chamber and carriage forward as two ears on the side of the brew chamber contact two pawls that force the brew chamber up. As the ears of the brew chamber clear the support of the pawls, the four brew chamber springs snap the brew chamber down, ejecting the spent tea into the chute which guides it to the waste bucket. The brewer then cycles home to await the next vend. If the variety of tea being used is not completely ejected with one cycle, then it may be necessary to extend the duration of channel 57 to cause the brewer cycle twice.

CUP DELIVERY SYSTEM

Every beverage sold through the AP 213 hot beverage merchandiser requires a clean disposable cup. Inside the machine is two storage areas for a large number of cups and a pair of adjustable cup separators (cup ring). The adjustable cup ring has been designed to dispense a wide variety of vending and non-vending cups. Each cup ring, after being properly adjusted, will dispense a single cup for each cycle of the machine. Included in the cup system are a cup present switch, for each cup cabinet, which will signal the logic board that no cups are available to dispense. The cup present switch is activated by a teardrop shaped actuator that pivots at the top of the teardrop. The actuator extends into the throat of the cup ring assembly. The logic board will either disable the respective START button, or if both cabinets are empty, change the scrolling display to an "OUT OF ORDER M01" message after trying to move the cups to the dispensing mechanism for 30 seconds.

CUP CABINET

Cups are stored in a pair of in line flat magazines mounted on the inside of the vendor door. The magazines are completely covered to protect the cups from accidental contamination. The entire cup cabinet may be swung out for easy access to the logic board, LED/switch board and selection labels. The base of the cup cabinet holds the cup dispense motor assembly platform.

Cups are moved from the storage position to the dispensing mechanism (referred to as the "cup drop") as needed. When the stack of cups in the cup drop throat has been reduced to four or five cups the cup present switch is released which signals the logic board to energize the cup spiral motor.

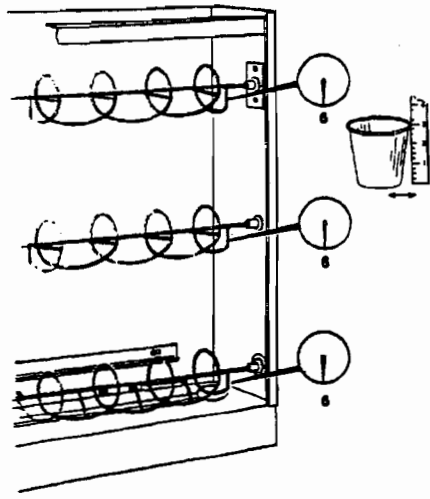

FIGURE 3.16

The cup spirals will turn simultaneously to advance the remaining stacks of cups on the base plate toward the cup drop opening.

When the stack of cups nearest the cup drop opening is advanced, it will drop into the remaining cups. The new cups will depress the cup present switch which signals the logic board to deactivate the cup spiral motor. The cup spirals are designed so that a stack of cups will nestle between the turns. It is important that the spirals are properly oriented to each other so the stacks of cups will advance in a vertical position.

The drawing illustrates the relationship between the three spirals. When the spirals are correctly adjusted, the return wire at the end of the spirals will point as shown. All three spirals should be pointing in the identical direction. The spirals are properly set before the machine leaves the factory and should not require adjustment before being put in service unless one of the cup sizes is changed. The synchronized movement of the three spirals is maintained by the toothed drive belts which connect the toothed gear on the end of each spiral rod and the cup spiral motor.

CUP DROP MECHANISM

The cup separator used in the AP 213 hot drink merchandiser is a patented adjustable cup separator developed by Automatic Products Int'l. The adjustable cup ring has been designed to dispense a wide variety of vending and non-vending cups. To successfully vend some of the non-vending cups, an alternate set of internal cams may be required. This set of alternate cams has a wider cut in the cam to allow the use of cups with very thick rims and can be identified by their color - black versus white for standard cams.

The cup to be dropped is separated from the rest of the cups in the stack by the spinning of the cams of the cup ring. The rotary motion of the cup drop motor is converted to a push-pull motion by a two piece crank arm which drives the lever of the cup drop ring. The lever of the cup ring is part of a large external ring gear which spins each of the individual cams. The cup is then guided to the cupwell by one of the two delivery chutes that are part of the cupwell. As the cams return to the starting position the next cup in the stack is prepared to be dropped for the next cycle. When the cup mechanism is in a standby position the lever of the cup ring is pushed against the arm of the cup motor cycle switch.

The cup dispenser motor and cup ring assembly are mounted on one easily removed assembly to allow easy access to the cup drop assembly. The two cup dispense platforms are identical and either cup ring can be readjusted so that the capacities reflecting the actual usage of cups can change. The cup dispense assemblies have two identical 4 pin plugs, located under the large dispenser, which are marked to correspond to their position and the START button which operates that cup size.

- ◆ Reversing the two 4 pin connectors will switch which start button operates the two cup dispensers.

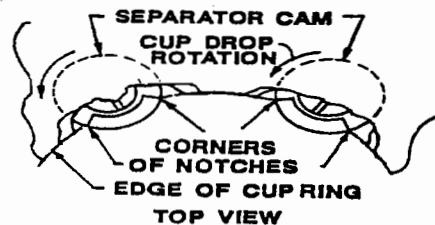

FIGURE 3.17

OPERATION OF CUP DROP MOTOR

Starting voltage for the cup drop motor goes to the normally open (NO) contact of the cycle switch which is being held closed by the lever of the cup drop ring. This starting voltage is controlled by channel 3 or 4, depending upon which size cup was selected. The run voltage for the cup drop motor is connected to the normally closed (NC) contact of the switch. The run voltage is always present on the NC terminal of the switch. The common of the switch is connected to the cup drop motor.

The run voltage remains on the NC contact of the switch for the duration of the vend. If the cup drop lever fails to interrupt the voltage by depressing the cycle switch, due to incorrect switch adjustment or a faulty switch the cup drop motor will run continuously.

If the start voltage remains on the NO contact of the switch longer than one complete revolution of the crank arm, the motor will run a second time. The length of the start voltage is controlled by the duration of channel 3 and 4.

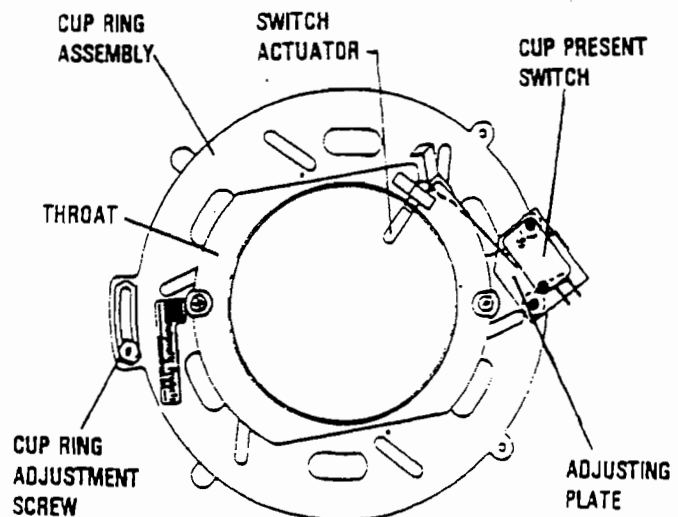

FIGURE 3.18

CUP DISPENSER ADJUSTMENTS & CHECKS

The following nine adjustment and check sections are required when the following is performed:

- Cup size change
- Cup brand Change
- Switching size cups from smaller to larger magazine.
- Troubleshooting if having any problem with cup operation.

1. SPIRAL ADJUSTMENT

The spirals are mounted in the cup cabinet by spiral positioning plates which allows for easy adjustment of the spiral positions to accommodate a large variety of cup sizes.

- A. See Figure 3.20 for spiral mounting positions for different size cups. Set all three spiral to the same mounting slots using the three spiral positioning plates on the left and three on the right side of the cup dispenser asm. Upon installing cups between the spirals, verify that the top and middle spiral has a space between its center shaft and the stack of cups of approximately 1/8 to 1/4 of an inch. If not, move spiral mounting positions in or out further as necessary.

This next adjustment check is to allow enough spiral rotation in order to prevent the stack of cups in the cup ring from leaning too far to the left in standby.

- B. See page 4.12 - Figure 3.16 which shows the spirals in the 6-6-6 position indicating all three spirals should be synchronized to the 6 o'clock direction. If not, perform following steps:
1. On the left side of the cup dispenser (drive belt side). Loosen the top and middle spiral mounting screws.
 2. Turn and hold bottom spiral to the 6 o'clock direction. Align the middle spiral to the bottom spiral then push up on the middle spiral until drive belt is snug then tighten the two mounting screws.
 3. Insure and hold bottom spiral is in 6 o'clock direction. Align the top spiral to the bottom spiral then push up on the top spiral until drive belt is snug then tighten its screws.
- ◆ *spiral belts should be snug not tight.*

2. CUP RING ADJUSTMENT

To correctly adjust the adjustable cup ring to fit the cups you are using (see Figure 3.18 & 3.19), the following procedure should be followed:

- A. Remove all existing cups in the throat of the cup drop.
- B. Locate the single adjustment screw & nut on the side of the cup ring opposite the white lever connected to the cup drop motor, and loosen screw 1/2 turn.
- C. Slide the adjustment lever so the cams are slightly smaller than the under rim diameter of the new cup being used.
- D. Place one cup in the cup ring and gradually slide the adjustment lever so the cup settles down on the shelf of the cam. Tighten the adjustment screw.
- E. Once the cup rim is resting on the shelf of the cam, a very minor adjustment may be required: using one finger, hold the cup up against one of the six cams, and gently push on the bottom of the cup, directly opposite your finger, towards your finger. If the cup slips off the opposite cam, then the cup ring is set too wide, and must be closed down slightly until the cup no longer falls off.
- F. Once the cup ring is correctly adjusted, tighten the locking screw and load the vend tube position with cups.
- G. Use Channel 3 or 4, in MODE 8 to test the adjustment by continuously dispensing a complete column of cups. At the end of the test, power down and up to reset the machine.

Optional cup ring adjustment gauges are available for purchase through your parts supplier using P/N 37663-XX (each gauge has a specific number for "XX" which will match the cup size being used).

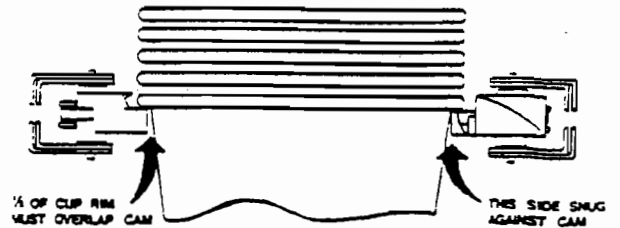

INCORRECT ADJUSTMENTS

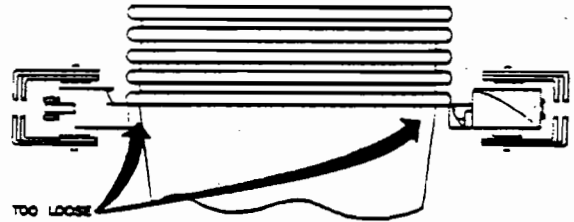
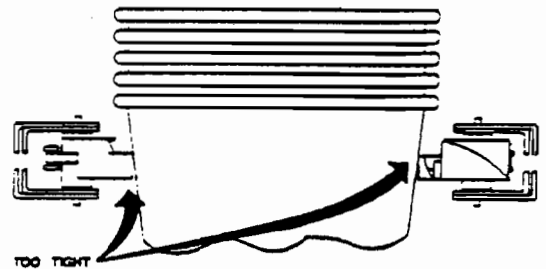

FIGURE 3.19

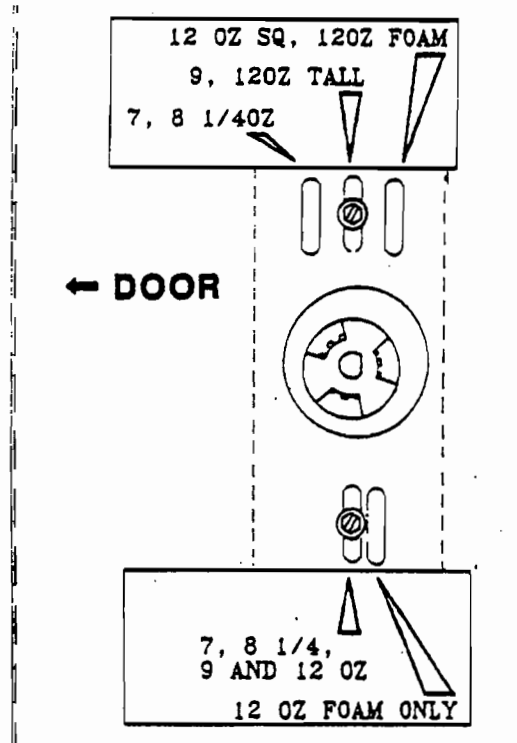

FIGURE 3.20

▼ USE FIGURE 3.21 TO AID YOU IN REFERENCING WHERE ITEMS ARE THROUGHOUT THE FOLLOWING CUP DISPENSER ADJUSTMENT PROCEDURES.

3. SEPARATOR BRACKET ADJUSTMENT

This adjustment is used to align the stack of cups in the cup ring to the end of the spirals. The other function is to insure that the bottom spiral indexes the new stack of cups correctly into the cup ring opening.

- A. Turn the bottom spiral [A] by hand until the sharp angle corner [B] on each spiral is pointing to the 9 o'clock position (towards door front).
- B. Grab a hold of the stack of cups [C] in the cup ring and position upright. If adjustment is correct the edge of the cup rims should barely be touching the bottom spirals right side when its pointing in the 9 o'clock position. If not, perform steps C and D below.
- C. Loosen the four mounting screws [D] and the nut holding the support bracket on the opposite side of cup separator asm.
- D. Slide the entire separator bracket asm left or right until the cup rims barely touch the bottom spiral right end. Tighten all screws and nut loosened.

4. GUIDE BAR ADJUSTMENT

Used to set a proper distance between the bottom section of stacked cups which are contoured shape and the bottom spiral shaft. The other important function is to help guide a new stack of cups into to center opening of the cup ring during indexing function.

- A. On the guide bar [E], there are horizontal upper and lower slots which will either position the guide bar in or out in order to position to bottom section of the cups to obtain a distance of 1/4 to 1/8 of an inch from the bottom spiral shaft [P]. Loosen guide bar screws and slide to the upper or lower slots in order to come closest measurement above.
- B. While holding the stack of cups [C] upright in separator asm, slide the guide bar left or right until its right corner angle [G] is approximately 1/8" to 3/16" from the cup rims in the cup ring separator.

5. REAR CHUTE ADJUSTMENT

This adjustment prevents cups from bouncing out of position while sliding down the rear cupwell chute. The following steps will insure alignment between the valley of the rear cupwell chute and cups hanging over this chute before dropping. This adjustment is only required for the rear cup dispenser assembly (rear cup dispenser refers to the less capacity magazine).

- A. If adjustment is correct, the bottom diameter of the cup hanging down from the rear separator should be centered over the valley of the rear slide chute [H] on the cupwell. If not, perform step B below.
- B. On cupwell chute, loosen the two brass thumb nuts and slightly move the top of chute left or right until its valley is centered beneath the bottom diameter of the cup in separator.

6. ANTI-TUMBLE ADJUSTMENT

Note: This adjustment is only for cup sizes 7 to 8 1/4 oz. being used in the rear dispenser asm (less capacity magazine).

This adjustment is used to prevent the smaller cup sizes from tumbling forward while dispensing down the rear chute.

- A. The extension chute can be found around the outside of the anti theft chute mounted under the cup ring. On the extension chute loosen the screw and nut until its loose enough to allow for movement up and down.
- B. Position and center the extension chute with its widest side over the lower section of the rear cupwell chute [H].

- C. Place and hold a cup in the rear cupwell chute [H] as if it were to slide down the chute. Move the extension chute up or down until the bottom edge of extension chute is approx. 3/8" to 1/2" above the cup rim being held in chute.

7. FULL CYCLE SWITCH ADJUSTMENT

Insures one complete cycle of the worm gears inside the cup ring and stops in proper standby position.

- A. In standby, check for a 1/4 inch gap between the left side opening in the cup ring housing [I] and the drive lever arm. If not, perform steps B through D.
- B. Switch off main power in machine.
- C. Hold the cup motor brake [N] in and move the motor drive arm until it's approximately 1/4 of an inch from the left side opening [I].
- D. Loosen the cycle switch bracket [J] from separator bracket [O], slide bracket outward then slowly move inward towards linkage until the switch can be heard or felt to click in, hold at that point and tighten mounting screws.

8. CUP PRESENT SWITCH ADJUSTMENT

This adjustment insures that the cups sold out and stop signal for new cups that have indexed functions correctly.

- A. Switch power off in machine. Fill the cup ring with cups up to the bottom spiral. Verify that this stack of cups is not being tilted due to the spring force of the actuator on the cup present switch [K]. If so, the switch adjustment is too close to the cups and must be loosened by performing step C below.
- B. Fill the cup ring with cups up to the middle spiral. Manually tilt the top of the cup stack away from the cup present switch and listen for the switch to deactivate. If the switch is not heard, adjustment is OK. If switch is heard, switch position is too loose, Perform step C below.
- C. Locate the cup present switch [K] by looking in the open side of the cup separator asm. On the bottom side of the switch/bracket, loosen the two mounting nuts with a small 1/4" open end wrench. The switch is on a mounting bracket that has one elongated slot used to adjust the switch actuator closer or looser up against the cup stack in ring. If too close, slightly move switch [K] away from cup ring, hold and tighten. If to loose, slightly move switch towards cup ring, hold and tighten. Re-perform steps A and B until adjustment is correct.

9. CUP DISPENSER TEST PROCEDURE

- A. Upon checking all adjustments, fully load cups in dispenser asm.
- B. Go into program Mode 7 and press the large start button.
- C. Enter the following channel number for model machine and size cup to be tested:

Model	Cup Size	Channel
213	Large	3
213	Regular	4

- D. Close and latch main door on machine.

NOTE: If any of the following steps fail, check for defective cups or recheck adjustments.

- E. Press large start button twice to drop a cup. Repeat this step until the entire cup stack in the separator runs empty.
- F. Open main door and insert two cups into empty cup ring then close door.
- G. Press coin return button to exit program. Enter credit amount for cup size in test.

NOTE: The next two steps will check for proper cup drop function and indexing of the new stack of cups into cup ring.

- H. Make a selection and listen for the spiral motor to turn on. A cup should not drop during this vend.
- I. Make a second vend and a cup should drop normally indicating successful index and cup drop operation.

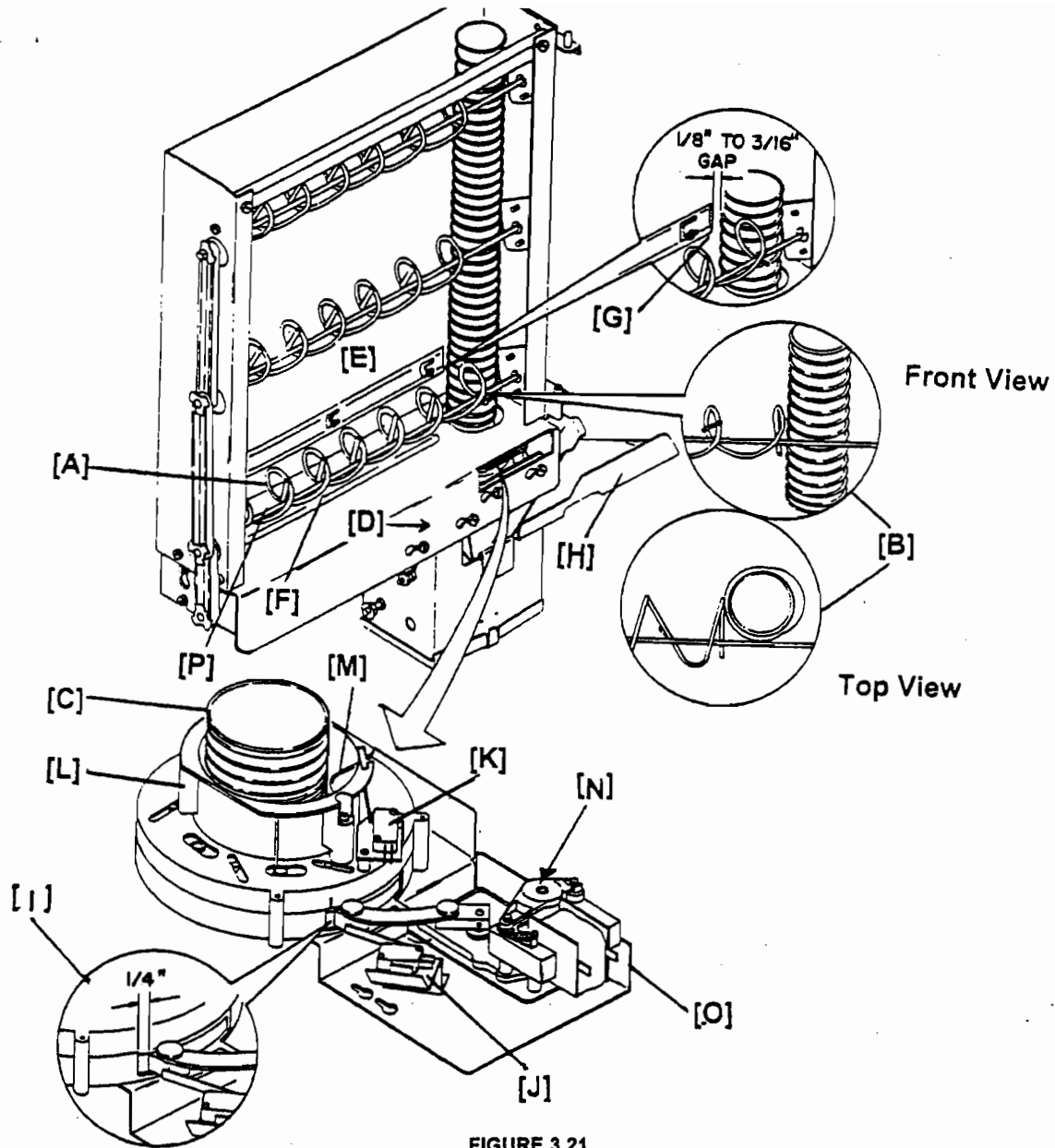

FIGURE 3.21

USE YOUR OWN CUP OPTION

An option available in the AP 213 detects the presence of a cup or mug in the cupwell and disables the cup dispense circuit. This option consists of three components, a printed circuit board with harness, a sensor assembly, and two sensor brackets mounted on each side of the cupwell, with two holes in the cupwell to allow the sensors to detect the presence of a cup. The two infrared sensors generate a light beam across the cupwell through two holes in the sides of the cupwell. If this beam is broken, the circuit board disables the cup drop start pulse. If the beam is blocked by the cupwell not being replaced correctly after service, or the sensors become covered for any reason, or the sensors and/or the circuit board fails to operate correctly, then the machine will not dispense a cup. The control board for the cup sensor is in a small box mounted under the center door stiffener next to the coin mechanism socket. Power for the cup sensor is now supplied via the harness for the viewer lamp located in the top inside left corner of the door. The original cup sensor used in all API machines interrupted the cup motor start pulse when a cup was placed in the cupwell. In a machine equipped with dual cups, the cup sensor board provides a closed circuit across the former cup present switch terminals (L13). This closed circuit will prevent either cup from being dispensed

when a cup is placed in the cupwell. The cup sensor also provides an additional harness to allow the cup sensor to discount the normal selling price when a customer uses their own cup. To activate this discount function, the connector from the discount switch (L11) is replaced with an identical two pin connector included in the cup sensor harness and accessing MODE 13 and setting the discount percentage to 8% (DISC .08). This discount percentage will decrease all vend prices between 15¢ and 60¢ by 5¢. If this function is used, then some other kits including the discount timer cannot be used for a free vend function. If it becomes necessary to disable the cup sensor, the only step necessary is to unplug the connector from the cup sensor control box.

LARGE GRINDER

The large grinder in a AP 213 Hot Drink Merchandiser is a high torque, heavy duty, 1/5 Hp electric motor capable of repeated operations of short duration. The beans are gravity fed from the bean hopper into the inlet throat of the grinder. The beans are then forced to the cutter heads by a solid screw type auger. The beans are then ground by two hardened steel cutter heads with meshing teeth. The inner cutter head is fixed to the motor frame and the outer cutter head is turned by the shaft of the grinder motor. The double flat sided shaft of the grinder motor is connected to the outer cutter head by a polycarbonate coupling with a corresponding slot.

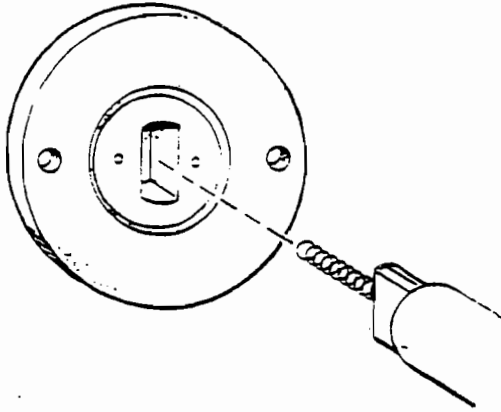

FIGURE 3.19

The coupling acts as a shock absorber and as protection for the grinder motor by shearing or rounding out if a foreign object becomes jammed between the cutter heads. Incorrect adjustment of the cutter heads or consistently grinding the coffee too fine can cause premature wear of the coupling. Correct adjustment of the cutter heads can be regained at any time by following the zero adjustment procedure on page 4.17. However, if an inconsistent grind is observed (chunks of un-ground beans and powdery dust in the same vend), then the grinder head should be disassembled and inspected for wear or damage to the coupling.

PROCEDURE FOR INSPECTION OF GRINDER HEAD

1. Open grinder swing out bracket. Pull out plunger on interlock switch to maintain power to the grinder. Close the gate on the bean hopper to prevent beans from entering the grinder.
2. Empty the grinder of beans and ground coffee. Grinder should be empty of beans before disassembly. The best method available to empty the grinder is:

Access **MODE 8** and select channel 5 and press **START**. Continuously run the grinder until it is empty of beans and press **START** again to stop the grinder.
Hold a container under the delivery chute to catch the grounds.
Remove the coffee delivery chute.

NOTE: If equipped with a small grinder or a LG canister, they must be removed from the swing out bracket. The mini grinder should be emptied using similar methods as above. The correct channel for the small grinder is channel 18.

3. After the grinder is empty, remove the two silver thumb nuts that secure the grinder adjustment dial and casting to the frame of the motor.
4. Remove and inspect the thrust bearing from the recess in the end of the coupling.

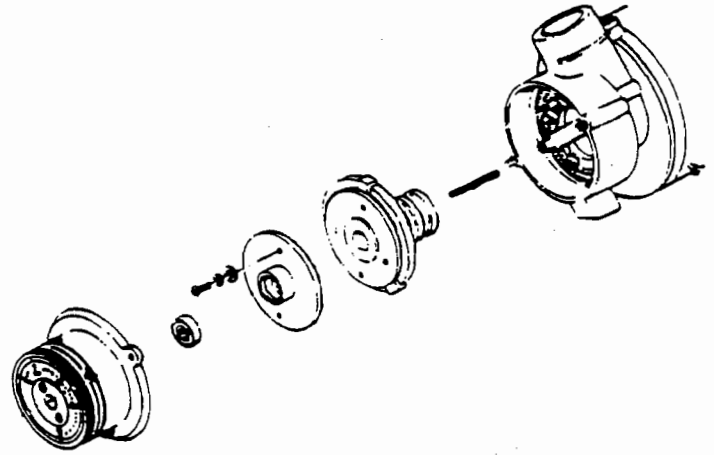

FIGURE 3.20

5. Remove outer cutter head assembly by pulling straight out on the cutter head and coupling.
6. Inspect the drive slot in the coupling by holding the cutter head assembly up to a light and sighting down the hole in the center of the auger.
7. If the edges of the slot are worn or rounded out, then it will be necessary to replace the coupling by removing the two screws that secure the coupling to the auger assembly.
8. Clean the grinder of any ground coffee or beans with a small stiff brush. Check for any evidence of a foreign object that could be present.
9. Assemble the grinder in reverse order, ensure that the spring is in the grinder shaft, the cutter head assembly is aligned correctly with the grinder shaft, and the bearing is replaced in the recess of the coupling.
10. Proceed to step 3 of the Static Zero Adjustment for the Large Grinder and complete the procedure from that point.

STATIC ZERO ADJUSTMENT FOR THE LARGE GRINDER

If, after a period of use, the brewed coffee becomes weaker or a variation in strength is detected and the grams of ground coffee, water temperature, etc. seems normal, it may be time to adjust the distance between the grinder plates. In order to maintain the consistency of the grind and the gram throw, a periodic zero adjustment may be needed for the best brewing results. Brewing efficiency can be regained by zero adjusting the grinder as outlined in the following steps.

1. Open grinder swing out bracket. Pull out plunger on interlock switch to maintain power to the grinder. Slide the gate on the bean hopper to prevent beans from entering the grinder.
2. Empty the grinder of beans and ground coffee. Grinder must be completely empty of beans before the zero adjustment can be made. The best method available to empty the grinder is:

Access **MODE 8** and select channel 5 and press **START**. Continuously run the grinder until it is empty of beans and press **START** again to stop the grinder. Hold a container under the delivery chute to catch the grounds. Remove the coffee delivery chute.

NOTE: If equipped with a small grinder or a LG canister, they must be removed from the swing out bracket. The mini grinder should be emptied using similar methods as above. The correct channel for the small grinder is channel 18.

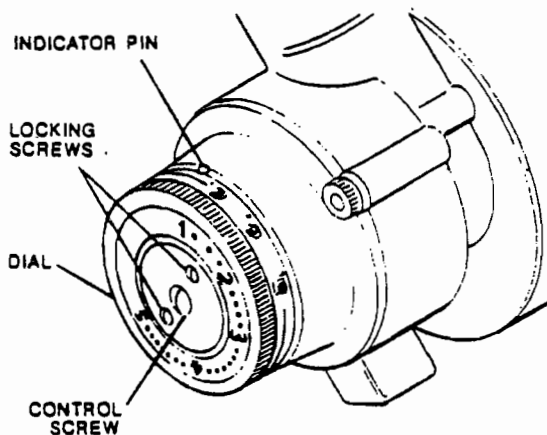
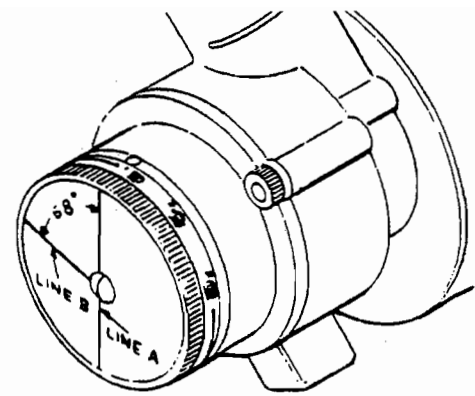

FIGURE 3.22

3. After the grinder is empty, turn the grind adjustment dial to the #1 position. The dial must be held in this position until the zero adjustment procedure is completed!
4. Loosen the two locking screws and turn the center control screw clockwise (facing the dial) until snug.
5. Place the adjustment gauge on the dial with Line A aligned with the slot on the control head screw.



ADJUSTMENT GAUGE IN POSITION

FIGURE 3.22

6. While holding the dial in the #1 position and the gauge stationary on the dial, turn the control screw counter-clockwise until the screw slot is aligned with Line B on the gauge (68 degrees), remove the gauge and tighten the two locking screws.
7. Open the gate to allow beans back into the grinder. Replace the coffee delivery chute. Return the dial to your original setting (between 2 1/2 and 3) and run 3 or 4 fresh brew vends to refill the grinder. Check the gram throw by accessing **MODE 12**, channel 5. Reset if necessary.
8. Return the swing out bracket to the operate position and run three test vends of regular coffee. If the brew cycle seems normal with no strain on the motor and acceptable dry spent grounds, leave the adjustment dial in its current position. If necessary to adjust the grind setting, recheck the gram throw. Open swing out bracket and replace any items removed in step 2 above.

ZERO ADJUSTMENT GAUGE FOR LARGE GRINDER

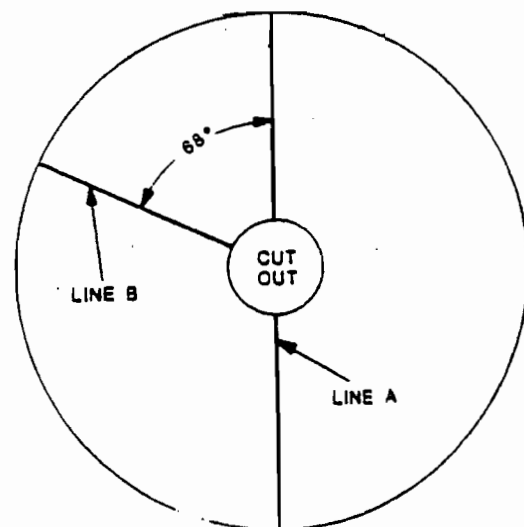

**GAUGE CAN BE COPIED
AND CUT OUT TO PERFORM
ZERO ADJ. PROCEDURE.**

STATIC ZERO ADJUSTMENT FOR THE MINI-GRINDER

If, after a period of use, the brewed decaf coffee becomes weaker or a variation in strength is detected and the grams of ground coffee, water temperature, etc. seems normal, it may be time to adjust the distance between the grinder plates. In order to maintain the consistency of the grind and the gram throw, a periodic zero adjustment may be needed for the best brewing results. Brewing efficiency can be regained by zero adjusting the grinder as outlined in the following steps.

1. Open grinder swing out bracket. Pull out plunger on interlock switch to maintain power to the mini-grinder. Slide the gate on the bean hopper to prevent beans from entering the mini-grinder.
2. Empty the mini-grinder of beans and ground coffee. Grinder must be completely empty of beans before the zero adjustment can be made. The best method to empty the mini-grinder is:

Access **MODE 8** and select channel 18 and press **START**. Continuously run the mini-grinder until it is empty of beans and press **START** again to stop the mini-grinder. Hold a container under the delivery chute to catch the grounds. Remove the coffee delivery chute. Remove the mini-grinder from the swing out bracket.

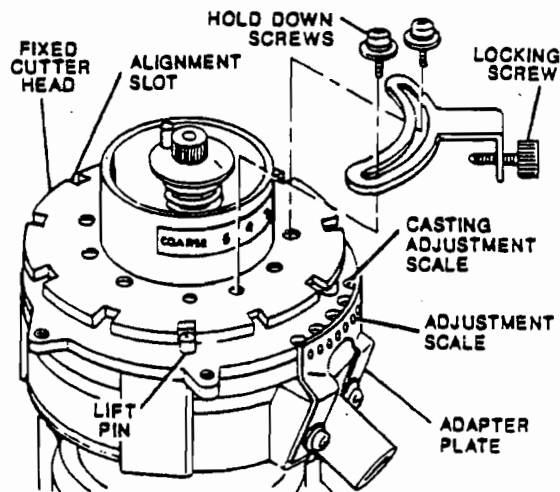

3. After the mini-grinder is empty, remove the locking device (pointer) & the locking screw from the top face of the fixed cutter head by removing the two screws and washers.
4. Turn the fixed cutter head of the mini-grinder counter-clockwise until hand tight.

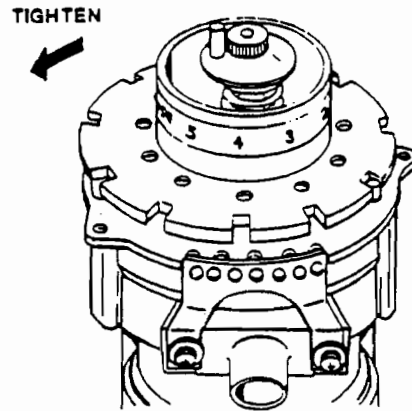

FIGURE 3.24

NOTE: This cutter head has a left hand thread.

5. Observe the relationship of the three spring-loaded lift pins and how they align with the ten slots on the outer edge of the fixed cutter head. If any of the three pins are aligned with any one of the 10 slots, you are ready for Step B. If none of the pins are aligned with any of the ten slots, slowly loosen the fixed cutter head clockwise until one pin is centered in any one of the ten slots on the outer edge of the fixed cutter head-proceed to Step B.
Step B - Continue turning the fixed cutter head clockwise until another pin is centered in any one of the ten slots. Continue turning the fixed cutter head clockwise until another pin is centered in any one of the ten slots. This is the #1 grind position. This is the finest grind of coffee that should be ground.

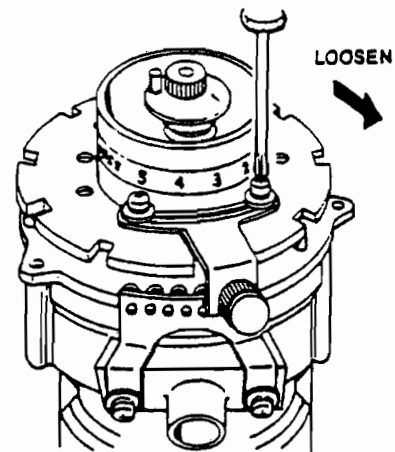

FIGURE 3.25

NOTE: Clicks can be heard at each position.

6. Reinstall the locking device removed in step 3 with the locking screw in the far right position in the adjusting scale. Tighten the two screws securing the locking device to the top of the fixed cutter head.

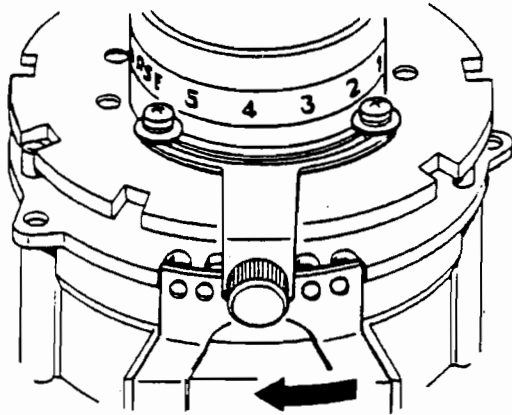

FIGURE 3.26

7. Move the locking screw to the center position on the adjustment scale. Using the adaptor plate with the 7 holes, then hole #4 will be the center position. Tighten the locking screw.
8. Reinstall the mini-grinder on the swing out bracket. Open the gate to allow beans back into the grinder. Replace the coffee delivery chute. Run 3 or 4 fresh brew decaf vends to refill the grinder. Check the gram throw by accessing **MODE 12**, channel 18. Reset if necessary.
9. Return the swing out bracket to the operate position and run three test vends of decaf coffee. If the brew cycle seems normal with no strain on the motor and acceptable dry spent grounds, leave the locking device in its current position. If necessary to adjust the grind setting, recheck the gram throw.

TROUBLESHOOTING FOR AP 213 HOT DRINK MACHINE

If **START/ENTER** does not operate- check security key switch for correct position. Key should be able to be removed. If key cannot be removed, then security key switch is on and the **START/ENTER** switch is disabled.

If **MODE** switch does not operate, check P11, P13 and P16 on the logic control board to determine if the **MODE** switch is reversed with the **DISCOUNT** switch or the **CUP PRESENT** switch. The **MODE** switch should be connected to P16. The **CUP PRESENT** switch should be connected to P13

If scrolling display on door shows "**OUT OF ORDER**": Refer to Appendix III-OUT OF ORDER CODES and check the three obvious reasons for the **OUT OF ORDER** message:

- 1) Buckets are full - **CODE M20**
- 2) Water tank is not full - **CODE M02**
- 3) Machine is out of cups - **CODE M01**

If either the water inlet valve or the cup spiral motor have been on for 90 continuous seconds the **OUT OF ORDER** message will appear. Another cause for the **OUT OF ORDER** message could be a constant low voltage source (i.e. -below 104Vac) from the wall outlet supplying the machine.

During initial set-up another situation may occur: If a logic board was changed or the software was changed, it may be necessary to proceed to **MODE 16** and reload the standard times. Caution should be observed because activating **MODE 16** will cause any channel time or price information that was changed from the standards to be lost. Further information on **MODE 16** can be obtained in the description of modes.

- ◆ If a logic board or software chip has been replaced and the board or chip is configured as a cold drink, the large grinder will immediately start to run. Swing the grinder swing out bracket out to interrupt power to the grinder and check **MODE 11** for the correct configuration ("H" flashing). Change the configuration and reload the factory standard times and settings in **MODE 16**.

Using the black mode switch located on inside of the door, set the display to **MODE 6** and press **START** button and check the list of switches that will appear on the display for the following switches and their correct operating position. This list of switches can be used to check each switch that functions as a sensor for the logic board. After running **MODE 6** test the first time and noting each switch number that appears, any switches' position can be physically changed to determine if the switch and its wiring to the logic board are correct. See Appendix I for selector switch assignments.

SWITCH #	INDICATION	WILL APPEAR IN NORMAL OPERATION
24 or below	faulty selector switch	N
25	discount switch	Y/N
26	auto flush enable switch	Y/N
27	bucket switch activated	N
28	cups sense input	Y/N
33	brewer water switch	Y
34	brewer cycle switch	Y
35	brewer delay switch	N
37	logic level jumper - heaters	Y
40	tank probe (ELLC)	N
46	cup present switch #1	Y
47	cup present switch #2	Y

- ◆ See APPENDIX II for additional switch descriptions.

EXAMPLE: Switch 27 (bucket switch activated or no AC power) will not show in **MODE 6** normally. After lifting the bucket switch, press **START** again to run another test. This time switch 27 should appear. This proves that the switch, the wiring from the switch to the logic board, and the sensor circuit on the logic board are functioning correctly. A similar test for any of the other switches can be devised.

After determining that the switches function correctly and a problem can be traced to a specific channel or device, the following procedure should be used to locate the source of the problem.

Check **MODE 11** to confirm that the correct options are set for the machine (Y/N).

Check the timing chart for the specific channel involved. Confirm the start and duration settings for the appropriate channel are correct by using the security key and accessing **MODE 12**. Check the times and run a channel test (after returning to **MODE 12**) by pressing the regular lightener selection. If the specific channel does not operate with the **MODE 12** test, proceed to **MODE 8** and select the faulty channel and press the **START** button. Once **START** is pushed, the function or device will have power applied to it and the problem can be located by using a voltmeter starting at the correct connector pins on the motor control board. The connectors must remain on the board to provide a load. If no voltage appears between the pin (determined by referring to the wiring diagram) and neutral (blue wire) then the problem is probably located in the motor control board. If voltage is present at the pins on the motor control board, then the problem is located downstream of the motor control board (i.e. between the motor control board and the device itself).

JUNCTION BOX CONNECTIONS

Visually inspect all connectors and terminals for any pins that have become loose or backed out of the connectors themselves. Also confirm that the numbers on the wires correspond to the correct pin numbers. One of the primary areas to examine for loose connectors or terminals backed out of connectors is in the junction box in the upper right front corner of the cabinet, near the hinge. The drawing below indicates the functions that pass through each connector of the junction box.

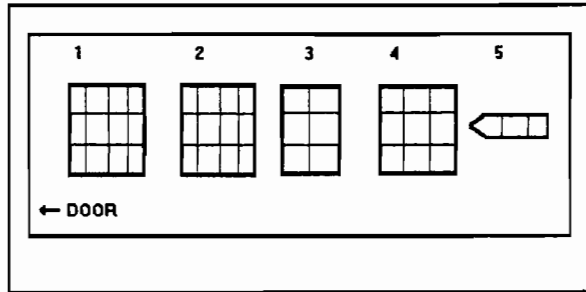

FIGURE 3.27

- Plug #1 12 pin .062 - 3 red wires, 1 green wire, 8 white wires. Contains all logic functions returning to the logic board. Functions affected are: water tank probe, 3 brewer switches, heater circuit jumper, 2 cup present switches
- Plug #2 12 pin .062 - all white wires. Interconnect harness between logic and motor control boards.
- Plug #3 6 pin .093 - Water bucket switch and humidity bar.
- Plug #4 9 pin .093 - All 110Vac functions for both cup dispensers and door including cup motor start pulse and spiral motor run. Also supplies voltage for viewer lamp, 110v supply voltage for coin mech, validator, and cup sensor.
- Plug #5 3 pin .062 - Cup present switches from cup cabinet. Connected inside junction box to Plug #1.

CHECKING INCOMING VOLTAGES

One of the common problems encountered with this machine is attempting to share a wall outlet with another machine, especially one that draws higher than normal current, like a can soda or another refrigerated machine. Allowing the hot drink and cold drink share the same outlet will result in repeated, and usually difficult to catch, service calls. The installation instructions in the front of the manual specify a dedicated 20 amp outlet. If you are experiencing unusual problems with a machine, one of the first areas to check is the wall outlet voltages. Referring to Figure 3.28, you should check the voltage at the wall outlet first, and then repeat the checks at the utility outlet inside the machine. You should be watching for any rapid changes in voltage, and all voltage tests should be repeated with the heaters on and the heaters off. Anytime you see rapid changes or exceed plus or minus 10% of the voltage ranges listed in the drawing, you have probably found the source of your problems. The only corrections you should make are moving any other machine on the same circuit as the coffee to another outlet or circuit. Any problems that you discover with a building's wiring should be reported to and corrected by an authorized person.

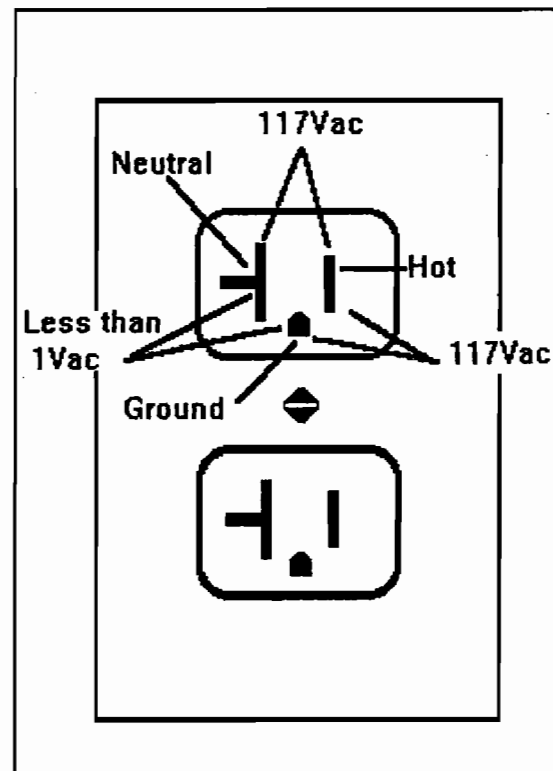

FIGURE 3.28

213 TROUBLESHOOTING CHART

PROBLEM	POSSIBLE CAUSE	REMEDY
Scrolling Display is Blank	Press any prime selection Does any selection LED come on?	YES-with any message proceed to MODE 17 to see if any user message is loaded
		YES-with no message- check ribbon cable from LCB to scrolling display to confirm that the cable is connected correctly. Confirm that a language chip is installed.
		NO Proceed to troubleshooting section regarding no power to machine.
Scrolling display shows: OUT OF ORDER	CODE M02 Water tank not full	Check inlet water valves.
		Power down-power up control circuit breaker to reset 90 second safety timer.
		Check for clogged water filter
		Check water supply for minimum incoming water pressure
	CODE M20 Buckets are full	Check bucket switches for correct operation.
		Measure MCB P7- 4&6 for -6.5Vdc with float swithes activated. Measure MCB P7 - 4&6 for 2.5 Vdc with either float switch deactivated .
	CODE M01 No cups	Check cups and cup present switches for correct adjustment.
		Power down-power up control circuit breaker to reset 30 second timer to allow spiral motor to run.
		Check cup present switch harness at connection to junction box
	CODE M20 Low supply voltage (115Vac)	Check wall outlet for 115Vac±10%
CODE M10 Software or logic board has been replaced	Check configuration in MODE 11 and reload MODE 16. Return to MODE 11 and recheck configuration and options	
16 Amp circuit breaker pops intermittently	Top thermostat mounting nuts overtightened	Loosen top standoffs that mount thermostats, tighten finger tight only evenly, then ¼ turn more with nut driver

213 TROUBLESHOOTING CHART

PROBLEM	POSSIBLE CAUSE	REMEDY
No power-complete machine including fluorescent light and service outlet	Power cord unplugged	Plug in power cord
	Loose or broken wire in power cord	Repair or replace
	Bad connections in power cord to EMI filter and switch panel	Check all terminals
	No voltage from wall outlet	Check outlet and supply circuit breaker
	On/off switch or wiring defective or open	Repair or replace
Machine will not vend or accept money	Circuit breaker(s) tripped	Reset or replace
	Power transformer disconnected or defective	Repair or replace
		Check MCB P1-3 and P1-5 for 24Vac
	Defective coin mechanism	Replace or disconnect and test machine using MODE 2
	110V coin mech won't operate	Check power board for 110Vdc-lower left corner of inside of door
MODE 13-MS1600 option is Y	Change to N	
Start/Enter does not operate	Security key switch is on	Key cannot be removed-return to off so key can be removed
	Defective LED/switch circuit board	Repair or replace
Bottom heater comes on first during initial power up	Thermostats wired incorrectly on tank lid	110Vac hot to center terminal, front thermostat
Excessive amount of liquid in overflow bucket	Probe assembly loose or incorrect length	Repair or replace switch
	Commodity water valve leaking	Repair or replace
	Water inlet valve leaking	Repair or replace-check supply line for high pressure. Install pressure regulator to correct.
	Flush cycle activating every 12 hours	Disable or reduce flush cycle or service machine more frequently
Lightener and/or sugar not selected but appearing in drink	Clogged exhaust system	Check steam exhaust (duct, hose, fan and humidity bar)-clean as needed
	Exhaust motor not running	Service or replace
	Scratched or defective trough causing poor wash	Replace
	Low spot in hose between whipper outlet and delivery spout	Trim hose to remove low spot
	Product mixed in canisters	Dump products and replace

213 TROUBLESHOOTING CHART

PROBLEM	POSSIBLE CAUSE	REMEDY
Wet grounds dispensed from brewer	Clogged brew filter	Replace
	Clogged filter support screen	Clean or replace
	Scored or cracked brew cylinder	Replace
	Worn or defective piston or seal	Replace
	Incorrect grind of coffee	Check grinder setting and refer to zero adjustment procedure
	Check gram throw	Using gram scale, adjust correct channels
	Soft water or coffee gases causing excessive pressure in brewer	Refer to Brewer section in manual
Large grinder operates, small grinder or decaf auger does not	Neutral for swing out bracket reversed	Check P10 and P11 on MCB 115Vac hot on P10-1 and P11-1 115Vac neutral on P10-2 and P11-2.
	Check configuration MODE 11-Option 2	Option 2 should be Y
	Check 2.5A circuit breaker on interlock switch bracket	Reset or replace
Grounds in cup	Brewer dumping wet grounds	See wet grounds section
	Torn or ripped brew filter	Replace
Weak and/or cold coffee and overfilling cup	Improper gram throw or grind	Check gram throw and grinder setting
	Brew water valve leaking	Repair or replace valve
	OVER TEMPERATURE safety thermostat popped	Reset and check overflow hose for low spots interfering with vent function
	Defective thermostat	Replace or bypass to test
	Defective or incorrectly wired interlock switch	Correct wiring or replace switch
	Defective heater	Test heater element and replace if defective - Heater Element resistance = 10Ω

213 TROUBLESHOOTING CHART

PROBLEM	POSSIBLE CAUSE	REMEDY
Cup occasionally not full (short cup)	Water inlet switch sticking or defective	Replace
	Check overflow hose for low spots causing vacuum condition	Straighten hose and drain any water, secure hose
	Float rod access cover loose	Secure in proper position
	Water valves opening late due to mechanical defect or low voltage	Repair or replace valve
	Brewer cable not adjusted properly causing brewer leak	Adjust cable
	Brewer stop position incorrect trapping grounds on seal	Adjust front brewer cam for correct stop position
	Check brew chamber seal for excessive grounds	Check for proper alignment of coffee delivery chute
	Clogged water filter	Replace
	Low water supply or damaged supply line	Change water supply or replace water supply line
	Liquid running down outside of small cups	Reposition hoses on delivery spout - use top 3 spouts
	Incorrect cylinder and carriage alignment	Check brewer cable adjustment
Water only-No coffee	Carriage wiper binding on filter	Confirm that brew filter is seated correctly Clean brew base assembly
	Warped brew filter	Replace
	Bent filter screen	Replace
	LG canister tunneling	Solenoid defective or disconnected Auger or agitator inoperative
	Bean hopper sliding gate closed	Open sliding gate
	Faulty interlock switch or assembly	Adjust or replace
	No coffee in canister	Service
	Check channels in MODE 12 for correct times	See timing chart
	Water in grounds bucket	Brew water valve leaking
Defective piston seal (wet grounds)		Replace
Incorrect cylinder and carriage alignment		Check brewer cable adjustment

213 TROUBLESHOOTING CHART

PROBLEM	POSSIBLE CAUSE	REMEDY
Selection or additive not working	Security key switch on or defective	Key cannot be removed-return to off so key can be removed
	Canister empty	Service machine
	Selection not activated	Check MODE 11 options
		Check for valid selection price - no prices set to \$99.99
	Canister rack motors not wired correctly	Correct wiring
	Additives do not flash during selection	Additives will not flash when Selections 4 or 5 are SGC
Defective selection switch/LED board	Run MODE 6 test and check for switch numbers - see page 2.07	
Machine vending with no money or returning money deposited and vending	Discount switch on with discount % set at 100%	Turn off discount switch
	Discount switch does not turn off free vending	Check for correct wiring of cup present and discount switches- LCB P-11 is discount switch, P-13 is cup present switch
	Free vend option set to YES	Check MODE 13, set free vend option to NO
	Free count option set incorrectly	Check MODE 13, set free count option correctly
	Selection price set to .00	Set price correctly-MODE 4 & 5
Pressing mode switch, does not enter service mode	Check for correct wiring of mode switch at LCB	Check LCB P-16 is mode switch
Pressing mode switch, enters service mode and immediately returns to operate	Coin mechanism sending reset pulse to logic board	Disconnect coin mechanism and try again
Pressing mode switch, cup spiral motor runs	Check for correct wiring of mode switch and cup present switch	Check LCB P-16 is mode switch, P-13 is cup present switch
Turning on discount switch enters a service mode	Check for correct wiring of discount switch and mode switch	Check LCB P-16 is mode switch, P-11 is discount switch

213 TROUBLESHOOTING CHART

PROBLEM	POSSIBLE CAUSE	REMEDY
Brewer leaking	Refer to brewer section in Service Manual	Soft water or coffee gases causing stalling or excessive pressure
	Excessive amount of coffee grounds on brew base assembly	Clean or service
		Check for correct alignment of coffee delivery chute on swing out bracket
	Cracked or damaged brew cylinder	Replace
	Special washers missing from between brew cylinder and cylinder rods	Replace
	Worn or damaged brew chamber seal	Replace
	Cracked or damaged brew chamber	Replace
	Worn filter or seal	Replace
	Cracked or damaged brew carriage	Replace
	Brew filter support bracket broken	Replace
	Improper brew cable adjustment	Adjust
	Funnel support brace bowed	Replace brew base frame
	Worn or broken delivery funnel	Replace
	Brew base assembly-parts worn or broken (springs, pawls, etc)	Replace parts
No cups	Cups jammed together in cup cabinet	Adjust or replace cup present switch
	Incorrect adjustable cup ring adjustment	Replace cups or cup ring
	Defective cup drop motor	Replace
	USE YOUR OWN CUP option not working	Cupwell not aligned correctly
		Sensors blocked or dirty
		Sensors or board malfunctioning
		See Service Section, page 3.12
Multiple or intermittent cups	Cup motor cycle switch out of adjustment, broken or defective	Adjust or replace
	Cup motor brake arm sticking on causing motor to coast	Check for rubber tip or brass grommet on brake arm - repair or replace
	Cup drop motor start pulse too long	Check MODE 12, channel 3 and 4 for correct duration
	Cup motor cycle switch wiring reversed	Correct wiring

DIRECTIONS FOR REPLACEMENT OF LOGIC CONTROL BOARD

DO NOT REMOVE THE BOARD OR THE EPROM WITHOUT CARRYING OUT THIS PROCEDURE!
NOTE DOWN ALL AUDIT DATA AND MACHINE SETTINGS IF POSSIBLE. THE FACTORY
STANDARD SETTINGS AND PRICES WILL BE LOADED AS A RESULT OF THIS PROCEDURE.



CAUTION: WHENEVER REPLACING OR HANDLING ANY ELECTRONIC CIRCUIT BOARD OR COMPONENTS, IT IS IMPORTANT! THAT YOU FOLLOW ELECTROSTATIC PREVENTATIVE MEASURES TO PREVENT STATIC DAMAGE TO THESE ITEMS. USE OF A GROUND STRAP OR OTHER GROUNDING METHOD TO MACHINE IS RECOMMENDED.

1. Open machine door.
2. Depress the mode switch until the display indicates "MODE 01".
3. Record all accountability information required by pressing the start switch and stepping through MODE 1.
4. Access MODE 4 and record all price setting information.
5. Insert security key into the service key switch, turn the switch to the "on" position and then back to the "off" position.
6. Depress the mode switch until the display indicates "MODE 12".
7. Depress the start switch. The display will indicate "CH 00"
8. Select all channels that have been changed from the factory standards and record the START, DURATION and MODIFIER times. To select a channel use the next digit switch and increment digit switches to select the desired channel and press ENTER/START to read the times from the scrolling display. Use the chart in Appendix IV to record information.
9. Depress the mode switch until the display indicates "MODE 13". Press ENTER/START and progress through the mode and record any changes from the factory standards.
10. Remove power from the machine and replace board and/or software EPROM noting the correct arrangement of all connectors or the orientation of the EPROM.
11. Restore power to the machine. Insert security key into the service key switch, turn the switch to the "on" position and then back to the "off" position. This allows the key to be removed and prevent it being left in the machine in error.
12. The display should indicate "MODE 11".
13. Depress the start switch. The display will indicate "CONFIG H/B/C". The "H" should be flashing to indicate that the machine is set up as a 213 hot drink machine.
14. If the "H" is not flashing press the change digit switch until it is. Then depress the START switch. The machine will then jump automatically to mode 16 to load the default values appropriate for the 213 machine. Go to step 16.
15. If the "H" (213) was flashing correctly depress the mode switch until the display indicates "MODE 16".
16. Depress the START switch and the display will continue to indicate "MODE 16". You have ENTERED MODE 16. Using the increment digit and next digit switches change the "16" to "27" and then depress the START switch. The display will go blank for 1-2 seconds.
17. When initialization and loading of the default values is complete the display will scroll the user message again.
18. Return to MODE 11, recheck configuration and set the machine options.
19. Access MODE 4 & 5 and set all selection prices.
20. Access MODE 12 and reset all channel times recorded in step 8 above. Proceed to MODE 13 and reset all payment options.

MOTOR CONTROL BOARD PIN CONNECTIONS

P1 LOGIC POWER SUPPLY

P1-1 110Vac to transformer primary (BLK)
 P1-2 110Vac return (BLK)
 P1-3 24Vac to motor control board (RED)
 P1-4 Key
 P1-5 24Vac return (RED)

P2 110Vac CONSTANT AND SWITCHED SUPPLY VOLTAGE

P2-0 Key (no board pin #)
 P2-1 110Vac to inlet water valves (to harness M2-2 wire)
 P2-2 Key
 P2-3 110Vac neutral (to harness M2-4 - blue wire)
 P2-4 110Vac constant supply (to harness M2-5 wire)
 P2-5 110Vac switched by bucket switches-disables all relay outputs - SWITCH #27 (to harness M2-6 wire)
 P2-6 Key (no board pin #)

P3 CUP DROP AND SPIRAL CONTROL

P3-1 Cup drop start pulse 110Vac controlled by channel 3
 P3-2 Cup spiral advance 110Vac- if on continuously for 90 seconds disables machine "Out of Order M01"
 P3-4 Key
 P3-5 110Vac neutral - If no wire is present, neutral is provided through P2-3

P4 BREWER AND SWING OUT BRACKET

P4-1 Brewer motor 110Vac-controlled by channel 7
 P4-2 Key
 P4-3 Brew water valve 110Vac-controlled by channel 8,19,28,42
 P4-4 Neutral 110Vac brewer and brew water valve
 P4-5 Regular coffee auger 110Vac (through swing out interlock) controlled by channel 6,17,26,39
 P4-6 Decaf auger motor 110Vac (through swing out interlock) controlled by channel 18,27,40

P5 COMMODITY VALVES-ALL 110Vac

P5-2 Commodity trough valve-controlled by channel 11,20,29,43,55
 P5-3 Brewed tea valve-controlled by channel 56
 P5-4 Chocolate valve-controlled by channel 35,68
 P5-5 Soup valve-controlled by channel 52,66
 P5-6 Key
 P5-7 Neutral

P6 CANISTER RACK-ALL 110Vac MOTORS

	CONTROLLED BY CHANNEL #
P6-3 Cup drop start pulse/small cabinet	4
P6-4 Cup spiral advance/small cabinet	3
P6-6 Sugar substitute	14,23,32,46,60
P6-7 FD gourmet	41
P6-8 FD coffee	6,17,26,39
P6-9 FD decaf	18,27,40
P6-10 Soup/SGC	52,65
P6-11 Tea FD or FB	54
P6-12 Lightener	12,21,30,45,58
P6-13 Sugar	13,22,31,44,59
P6-14 Key	
P6-15 Neutral	
P6-16 Chocolate auger	34,67
P6-17 Chocolate whipper	35,68
P6-18 Soup whipper	53,66
P6-19 Tea brewer motor	57
P6-22 Coffee whipper motor	15,24,33,47,61

P7 MOTOR CONTROL TO LOGIC CONTROL INTERFACE

P7-1 24Vac hot
 P7-2 24Vac return
 P7-3 24Vdc hot
 P7-4 6.5Vdc measured to dc ground
 P7-5 DC ground
 P7-6 AC present through overflow switches = 6.5Vdc measure to P7-4. Should drop to 2.5Vdc when overflow bucket circuit is open
 P7-7 through 11 Data transfer lines

P8 WATER HEATER CIRCUIT DIRECT CONTROL THERMOSTATS

P8-1 Not used
 P8-2 110Vac Neutral
 P8-3 110Vac Constant for both heaters

P10 GRINDER POWER

P10-1 Large grinder 110Vac-controlled by channel 5,16,25,38
 P10-2 Neutral for large grinder and swing out bracket

P11 110Vac IN TO MOTOR CONTROL BOARD FOR GRINDER AND HEATERS

P11-1 110Vac hot
 P11-2 110Vac neutral

LOGIC CONTROL BOARD PIN CONNECTIONS

P1 INTERCONNECT TO MOTOR CONTROL BOARD

- P1-1 24Vac hot
- P1-2 24Vac ground
- P1-3 24Vdc hot
- P1-4 6.5Vdc measured to dc ground
- P1-5 dc ground
- P1-6 AC present through overflow switches = 6.5Vdc measure to P1-4. Should drop to 2.5Vdc when overflow bucket circuit is open.
- P1-7 through 11 Data transfer lines

P6 COIN MECHANISM

- P6-1 24Vdc return to pin 13 coin mech
- P6-2 Key
- P6-3 24Vdc hot to pin 15 coin mech
- P6-4 Key
- P6-5 Data line to pin 5 coin mech
- P6-6 Interrupt line to pin 4 coin mech
- P6-7 Accept Enable to pin 6 coin mech
- P6-8 Reset to pin 11 coin mech
- P6-9 Send line to pin 3 coin mech
- P6-10 5Vdc hot to pin 1 coin mech
- P6-11 dc ground to pin 2 coin mech
- P6-12 .05 dispense line to pin 9 coin mech
- P6-13 .10 dispense line to pin 8 coin mech
- P6-14 .25 dispense line to pin 7 coin mech

P15 BILL VALIDATOR

- P15-1 Escrow high
- P15-2 \$1 high
- P15-3 \$2 high
- P15-4 \$5 high
- P15-5 Escrow low
- P15-6 \$1 enable
- P15-7 \$2 enable
- P15-8 \$5 enable
- P15-9 Bill validator credit pulses
- P15-10 Key
- P15-11 Dc ground
- P15-12 24Vac hot
- P15-13 24Vac return
- P15-14 +15Vdc
- P15-15 +6.5Vdc

NOTE: THE FOLLOWING CONNECTORS ARE SENSORS ONLY AND ALL TESTING SHOULD BE DONE WITH POWER OFF AND CONNECTOR REMOVED FROM THE CIRCUIT BOARD. THE ONLY TEST THAT SHOULD BE DONE IS A CONTINUITY TEST TO CHECK THE SWITCH FOR CORRECT OPERATION.

P7 ELECTRONIC LIQUID LEVEL CONTROL SWITCH #40

- P7-1 To tank lid ground
- P7-3 Key
- P7-4 Tank probe

P8 CUP PRESENT SWITCHES

- P8-4 Cup present switch - small cabinet (N.C.) SWITCH # 46
- P8-6 Cup present switch - large cabinet (N.C.) SWITCH # 47
- P8-8 KEY - No connection
- P8-9 Common - scan line

P9 BREWER CONTROL CIRCUIT

- P9-1 Brewer delay switch-SWITCH #35
- P9-2 Key
- P9-3 Common
- P9-4 Brewer cycle switch-SWITCH #34
- P9-5 Brewer water switch-SWITCH #33

P10 LOGIC JUMPER - DIRECT CONTROL THERMOSTATS

- P10-1 Common
- P10-5 Connected to P10-1 at tank-SWITCH #37

P11 DISCOUNT SWITCH-SWITCH #25

- P11-1 Common
- P11-2 Discount switch (N.O.)

P12 FLUSH INTERLOCK SWITCH-SWITCH #26

- P12-1 Common
- P12-2 Flush interlock switch (N.O.)

P13 CUP SENSOR INPUT - SWITCH #28

- P13-1 Common
- P13-2 Cup sensor input (N.O.)

P16 MODE SWITCH-SWITCH #30

- P16-1 Common
- P16-2 Mode switch (N.O.)

P17 CYCLE LED

- P17-1 Common
- P17-2 LED

LED PRINTED CIRCUIT BOARD PIN CONNECTIONS

- LP2-1 THRU 25 INTERCONNECT TO LOGIC CONTROL
- LP3-1 THRU 7 SECURITY KEY SWITCH #32

CREDIT POWER BOARD CONNECTIONS

USED ONLY WITH 110V COIN MECH AND/OR VALIDATOR

- P1-1 110V ac hot input (blue)
- P1-2 Key - no connection
- P1-3 110V ac neutral input

- P2-1 110V dc ground to coin mech socket pin 10
- P2-2 110V dc hot to coin mech socket pin 12
- P2-3 Key - no connection
- P2-4 No connection

- P3-1 110V ac neutral to validator pin 6
- P3-2 Key - no connection
- P3-3 110V ac hot to validator pin 4

