

Brio3

Espresso

USA English



DOC. NO. **H 270U 00**
EDITION 1 2006 - 03

N&W GLOBAL VENDING S.p.A.

Sede legale: Via Roma 24
24030 Valbrembo (BG) Italia

Telefono +39 035 606111
Fax +39 035 606460
www.nwglobalvending.com

Cap. Soc. € 40.000.000 i. v.
Reg. Imp. Bergamo, Cod. Fisc. e Part. IVA: 03138870161
R.E.A. Bergamo n. 352618
Cod. ISO: IT 03138870161

DICHIARAZIONE DI CONFORMITA'
DECLARATION OF CONFORMITY
DÉCLARATION DE CONFORMITÉ
KONFORMITÄTSEKTLÄRUNG
DECLARACIÓN DE CONFORMIDAD
DECLARAÇÃO DE CONFORMIDADE
VERKLARING VAN OVEREENSTEMMING
INTYG OM ÖVERENSSTÄMMELSE
OVERENSSTEMMELSESERKLÆRING
YHDENMUKAISUUSTODISTUS

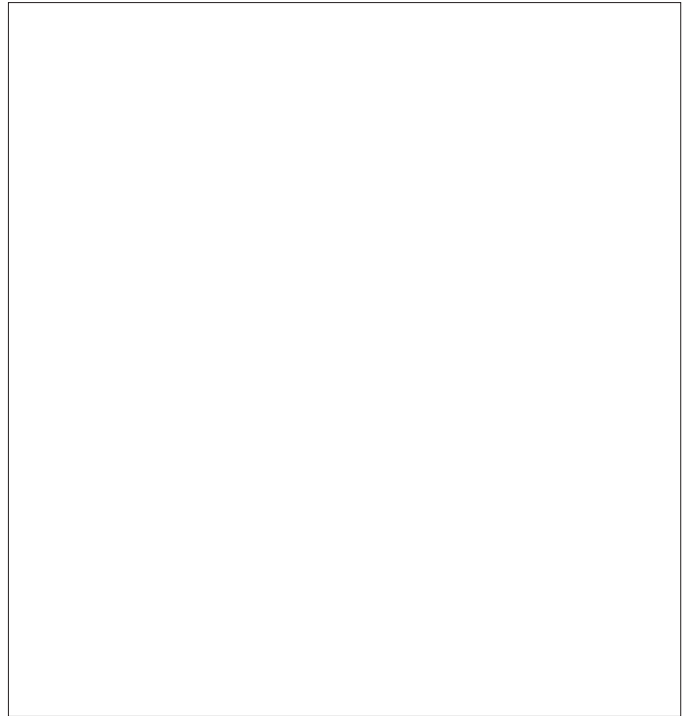

Valbrembo, 01/04/2005

Dichiara che la macchina descritta nella targhetta di identificazione, è conforme alle disposizioni legislative delle direttive: **98/37/CE, 89/336, 73/23 CEE** e successive modifiche ed integrazioni.

Declares that the machine described in the identification plate conforms to the legislative directions of the directives: **98/37/CE, 89/336, 73/23 EEC** and further amendments and integrations.

Déclare que l'appareil décrit dans la plaque signalétique satisfait aux prescriptions des directives: **98/37/CE, 89/336, 73/23 CEE** et modifications/intégrations suivantes.

Erklärt, daß das im Typenschild beschriebene Gerät den **EWG** Richtlinien **98/37/CE, 89/336, 73/23** sowie den folgenden Änderungen/Ergänzungen entspricht.

Declara que la máquina descrita en la placa de identificación, resulta conforme a las disposiciones legislativas de las directivas: **98/37/CE, 89/336, 73/23 CEE** y modificaciones y integraciones sucesivas.

Declara que o distribuidor descrita na chapa de identificação é conforme às disposições legislativas das directivas **98/37/CE, 89/336 e 73/23 CEE** e sucessivas modificações e integrações.

Verklaart dat de op de identificatieplaat beschreven machine overeenstemt met de bepalingen van de **EEG** richtlijnen **98/37/CE, 89/336 en 73/23** en de daaropvolgende wijzigingen en aanvullingen.

Intyggar att maskinen som beskrivs på identifieringsskylten överensstämmer med lagstiftningsföreskrifterna i direktiven: **98/37/CE, 89/336, 73/23 CEE** och påföljande och kompletteringar.

Det erklæres herved, at automaten angivet på typeskiltet er i overensstemmelse med direktiverne **98/37/CE, 89/336 og 73/23 EU** og de senere ændringer og tillæg.

Forsikrer under eget ansvar at apparatet som beskrives i identifikasjonsplaten, er i overensstemmelse med vilkårene i EU-direktivene **98/37/CE, 89/336, 73/23** med endringer.

Vahvistaa, että arvokyltissä kuvattu laite vastaa **EU-direktiivien 98/37/CE, 89/336, 73/23** sekä niihin myöhemmin tehtyjen muutosten määräyksiä.

ANTONIO CAVO
C.E.O

®



THE INTERNATIONAL CERTIFICATION NETWORK

CERTIFICATE

IQNet and its partner
CISQ/IMQ-CSQ

hereby certify that the organization

N&W GLOBAL VENDING SPA

VIA ROMA 24 - 24030 VALBREMBO (BG) Italy

VIA DEL CHIOSO ANG. CAPITANI DI MOZZO - 24030 MOZZO (BG) Italy

for the following field of activities

Design, manufacturing and sale of electronic/electromechanical vending machines

Refer to quality manual for details of applications to ISO 9001:2000 requirements

has implemented and maintains a

Quality Management System

which fulfills the requirements of the following standard

ISO 9001:2000

Issued on: 2005 - 07 - 11

Registration Number: **IT - 12979**



Fabio Roversi
President of IQNet



Gianrenzo Prati
President of CISQ

IQNet partners:*

AENOR Spain AFAQ France AIB-Vincotte International Belgium ANCE Mexico APCER Portugal CISQ Italy CQC China
COM China COS Czech Republic DQS Germany DS Denmark ELOT Greece FCVY Brazil FONDONORMIA Venezuela
HKQAA Hong Kong ICONTEC Colombia IMAC Mexico IRAM Argentina IQA Japan KEMA Netherlands KUO Korea MSZT
Hungary Nemko Certification Norway NSAI Ireland DQS Austria PCB Poland PSB Certification Singapore QMI Canada RR Russia
SAI Global Australia SES Finland SHI Israel SIQ Slovenia SQS Switzerland SRAC Romania TEST St Petersburg Russia
IQNet is represented in the USA by the following partners: AFAQ, AIB-Vincotte International, CISQ, DQS, KEMA, NSAI, QMI and SAI Global
*The list of IQNet partners is valid at the time of issue of this certificate. Updated information is available under www.iqnet-certification.com

CISQ is a member of
IQNet
INTERNATIONAL CERTIFICATION NETWORK
www.iqnet-certification.com

IQNet, the association of the world's first class certification bodies, is the largest provider of management system certification in the world. IQNet is comprised of more than 30 bodies and counts over 150 subsidiaries all over the globe.



www.imq.it

CERTIFICATO N. 9191.ZAV2
CERTIFICATE N.

SI CERTIFICA CHE IL SISTEMA DI GESTIONE AMBIENTALE DI
WE HEREBY CERTIFY THAT THE ENVIRONMENTAL MANAGEMENT SYSTEMS OPERATED BY

N&W GLOBAL VENDING SPA
VIA ROMA 24 - 24030 VALBREMBO (BG)

SITI
SITES

VIA ROMA 24 - 24030 VALBREMBO (BG)
E' CONFORME ALLA NORMA
IS IN COMPLIANCE WITH THE STANDARD

ISO 14001

PER LE SEGUENTI ATTIVITA'
FOR THE FOLLOWING ACTIVITIES

Progettazione, produzione e vendita di apparecchiature elettromeccaniche/elettroniche per
distribuzione automatica e ristorazione

Electronic/electromechanical vending machines

IL PRESENTE CERTIFICATO E' SOGGETTO AL RISPETTO DEL REGOLAMENTO
PER LA CERTIFICAZIONE DEI SISTEMI QUALITA' E DI GESTIONE DELLE AZIENDE
THE USE AND THE VALIDITY OF THE CERTIFICATE SHALL SATISFY THE REQUIREMENTS
OF THE RULES FOR THE CERTIFICATION OF COMPANY QUALITY AND MANAGEMENT SYSTEMS

PRIMA EMISSIONE
FIRST ISSUE
1997-12-19

EMMISSIONE CORRENTE
CURRENT ISSUE
2005-07-11

IMQ S.p.A. - VIA QUINTILIANO, 43 - 20138 MILANO

CISQ è la Federazione Italiana di Organismi di Certificazione del Sistema di Gestione Ambientale
CISQ is the Italian Federation of management system Certification Bodies



SINCERT
SISTEMI INTEGRATI
CERTIFICAZIONE
SISTEMI INTEGRATI
CERTIFICAZIONE
SISTEMI INTEGRATI
CERTIFICAZIONE

La validità del presente certificato è subordinata a solvibilità annuale e al riesame completo del Sistema di Gestione Ambientale con periodicità triennale secondo le procedure dell'IMQ
The validity of the certificate is submitted to annual audit and a reassessment of the entire Environmental Management System within three years according to IMQ rules

www.cisq.com

TABLE OF CONTENTS

INTRODUCTION	PAGE 2	NOTES ON PROGRAMMING	PAGE 16
IDENTIFICATION OF THE VENDING MACHINE	PAGE 2	POWER ON	PAGE 16
IN CASE OF FAILURE	PAGE 2	OPERATING MODES	PAGE 16
TRANSPORT AND STORAGE	PAGE 2	NORMAL OPERATING MODE	PAGE 16
POSITIONING THE VENDING MACHINE	PAGE 3	SURFING MODE	PAGE 17
WARNING FOR INSTALLATION	PAGE 3	FILLER MENU	PAGE 17
PRECAUTIONS IN USING THE MACHINE	PAGE 3	STATISTICS	PAGE 17
WARNING FOR SCRAPPING	PAGE 3	SELECTION PRICES	PAGE 17
TECHNICAL SPECIFICATIONS	PAGE 3	CHANGE TUBES CONTROL	PAGE 18
POWER CONSUMPTION	PAGE 4	DISPLAYING THE TEMPERATURE	PAGE 18
VARIABLE COMBINATION LOCK	PAGE 5	TEST DISPENSING	PAGE 18
ACCESSORIES	PAGE 5	GSM PRE-ALARMS	PAGE 18
LOADING AND CLEANING	PAGE 6	EVADTS TRANSFER	PAGE 18
DOOR SWITCH	PAGE 6	FILLER MENU MASKING	PAGE 18
CLEANING AND DISINFECTION	PAGE 6	TECHNICIAN MENU	PAGE 19
USING THE VENDING MACHINE	PAGE 6	FAILURES	PAGE 19
CONTROLS AND INFORMATION	PAGE 7	PROGRAMMING PARAMETERS	PAGE 20
LOADING CUPS	PAGE 7	STATISTICS	PAGE 26
LOADING COFFEE	PAGE 8	TEST	PAGE 27
LOADING SUGAR AND INSTANT PRODUCTS	PAGE 8	MAINTENANCE	PAGE 30
SANITISING THE MIXERS AND THE FOODSTUFF CIRCUITS	PAGE 8	INTRODUCTION	PAGE 30
CLEANING THE WATER SUPPLY TANK	PAGE 9	ESPRESSO UNIT MAINTENANCE	PAGE 30
CLEANING THE WASTE TRAYS	PAGE 9	CLEANING THE CUP DISPENSER	PAGE 31
CLEANING THE CUP SHIFT ARM	PAGE 9	PERIODICAL CLEANING	PAGE 31
CLEANING THE SUGAR DISPENSER	PAGE 10	PRINTED BOARD FUNCTIONS AND INDICATOR LAMPS	PAGE 32
PERIODIC CLEANING THE COFFEE UNIT	PAGE 10	ACTUATION BOARD	PAGE 32
SUSPENDING FROM USE	PAGE 10	PUSH-BUTTON BOARD	PAGE 33
INSTALLATION	PAGE 11	C.P.U. BOARD	PAGE 33
DOOR SWITCH	PAGE 11	CONFIGURING THE ELECTRONIC BOARDS	PAGE 34
UNPACKING THE VENDING MACHINE	PAGE 11	SOFTWARE UPDATE	PAGE 34
INSERTING THE LABELS	PAGE 12	HYDRAULIC SYSTEM	PAGE 35
CONNECTION TO THE WATER MAINS	PAGE 12	MENU SUMMARY	PAGE 38
WATER SOFTENER UNIT	PAGE 12	WIRING DIAGRAM	PAGE 44
CONNECTING TO THE POWER SUPPLY	PAGE 12		
INSTALLING THE PAYMENT SYSTEM	PAGE 13		
FILLING THE WATER SYSTEM	PAGE 13		
INSTALLATION IN A BANK OF MACHINES	PAGE 13		
COFFEE UNIT OPERATION	PAGE 14		
COFFEE DISPENSING CYCLE	PAGE 14		
CHECKING AND ADJUSTING THE MACHINE SETTINGS	PAGE 14		
STANDARD SETTINGS	PAGE 15		
ADJUSTING THE BREWING CHAMBER VOLUME	PAGE 15		
ADJUSTING THE GRADE OF GRINDING	PAGE 15		
ADJUSTING THE COFFEE DOSE	PAGE 15		
WATER TEMPERATURE CONTROL	PAGE 15		

INTRODUCTION

This technical documentation is part and parcel of the vending machine and must always follow the machine in case it is moved or transfer of ownership, so as to allow consultation by different operators.

Before starting installation and using the machine, it is first necessary to carefully read and understand the instructions contained in this manual, as they offer important information on installation safety, operating instructions and maintenance.

This manual is divided into three chapters.

The **first chapter** describes the loading and routine maintenance operations which are carried out in areas of the machine accessible with simple use of the door key, without using any other tools.

The **second chapter** contains the instructions for correct installation and all information necessary for optimum use of the machine.

The **third chapter** describes maintenance operations which involve the use of tools to access potentially dangerous areas.

The operations described in the second and third chapters must be carried out only by personnel who have the specific knowledge of the machine functioning from a point of view of electrical safety and health regulations.

IDENTIFICATION OF THE VENDING MACHINE AND ITS CHARACTERISTICS

Every machine is identified by its own serial number, indicated on the rating plate attached inside the cabinet on the right side.

This plate is the only one acknowledged by the manufacturer as identification of the machine, and carries all data which readily and safely gives technical information supplied by the manufacturer. It also assists in the spare parts management.

IN CASE OF FAILURE

In most cases, any technical problems are corrected by small repair operations; however, before contacting the manufacturer we recommend that this manual be read carefully.

Should there be serious failures or malfunctions, then contact the following:

N&W GLOBAL VENDING S.p.A.
Via Roma 24
24030 Valbrembo - BG
Italy - Tel. +39 035606111

TRANSPORT AND STORAGE

To prevent any damage, special care should be taken when loading or unloading the vending machine.

The machine can be lifted by a motor-driven or manual forklift truck, and the forks are to be placed underneath the machine from the side clearly indicated by the symbol on the cardboard package.

Do not:

- overturn the vending machine;
- drag the vending machine with ropes or similar;
- lift the vending machine by its sides;
- lift the vending machine with slings or ropes;
- shake or jolt the vending machine and its packing.

The machine should be stored in a dry room where the temperature remains between 0°C and 40°C.

Avoid stacking machines one on top of the other and always keep it upright as indicated by the arrows on the packing.

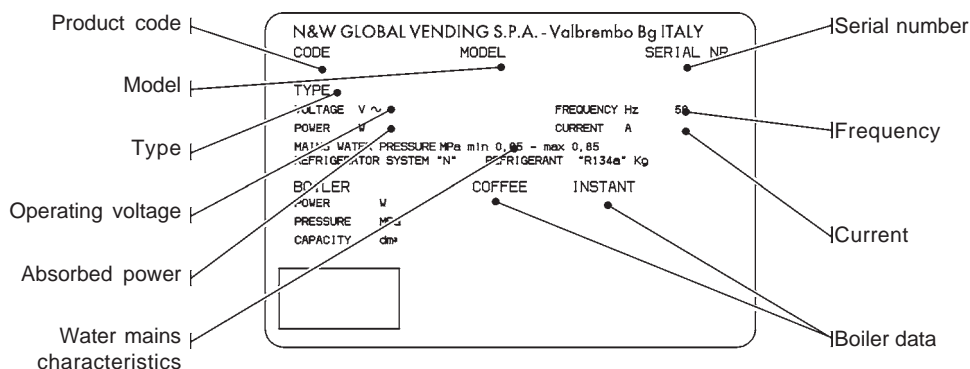

Fig. 1

POSITIONING THE VENDING MACHINE

The vending machine is not suitable for outdoor installation. It must be positioned in a dry room where the temperature remains between 2°C and 32°C, and not where water jets are used for cleaning (e.g. in large kitchens, etc.).

The machine should be placed close to a wall, so that the back panel is at a minimum distance of 4 cm from it and correct ventilation may be ensured. The machine must never be covered with cloth or the like.

The machine should be positioned with a maximum inclination of 2°.

If necessary provide proper levelling by way of the adjustable feet included.

Important notice!!

Access to the machine interior for maintenance and/or repairs is via the back panel.

Therefore the machine is designed to be rotated, thus allowing removal of the back panel.

Installation on a cabinet

The machine can be installed on a table or on any other suitable stand (recommended height is 800).

If possible, it is advisable to use the special base cabinet, which can house the liquid waste tray, the water supply kit, the payment system and, in the case of very hard water, the softener unit.

WARNING FOR INSTALLATION

The machine installation and the following maintenance operations should be carried out by qualified personnel only, who are trained in the correct use of the machine according to the standards in force.

The machine is sold without payment system, therefore the installer of such system has sole responsibility for any damage to the machine or to things and persons caused by faulty installation.

The integrity of the machine and compliance with the standards of the relevant systems must be checked at least once a year by qualified personnel.

All packing materials shall be disposed of in a manner which is safe for the environment.

PRECAUTIONS IN USING THE MACHINE

The following precautions will assist in protecting the environment:

- use biodegradable products only to clean the machine;
- adequately dispose of all containers of the products used for loading and cleaning the machine;
- switch the machine off during periods of inactivity, thus achieving considerable energy savings.

WARNING FOR SCRAPPING



The symbol  indicates that the machine may not be disposed of as ordinary waste; it must be disposed of in accordance with the provisions of the European directive 2002/96/CE (Waste Electrical and Electronics Equipments - WEEE) and of any resulting national laws, for preventing any possible negative consequences to the environment and to health.

For correct disposal of the machine, contact the dealer from whom you have purchased the machine or our after-sales service.

TECHNICAL SPECIFICATIONS

Height	760	mm
Dimension with top panel lifted	1030	mm
Width	540	mm
Depth	585	mm
Overall depth with door open	1000	mm
Weight	65	Kg

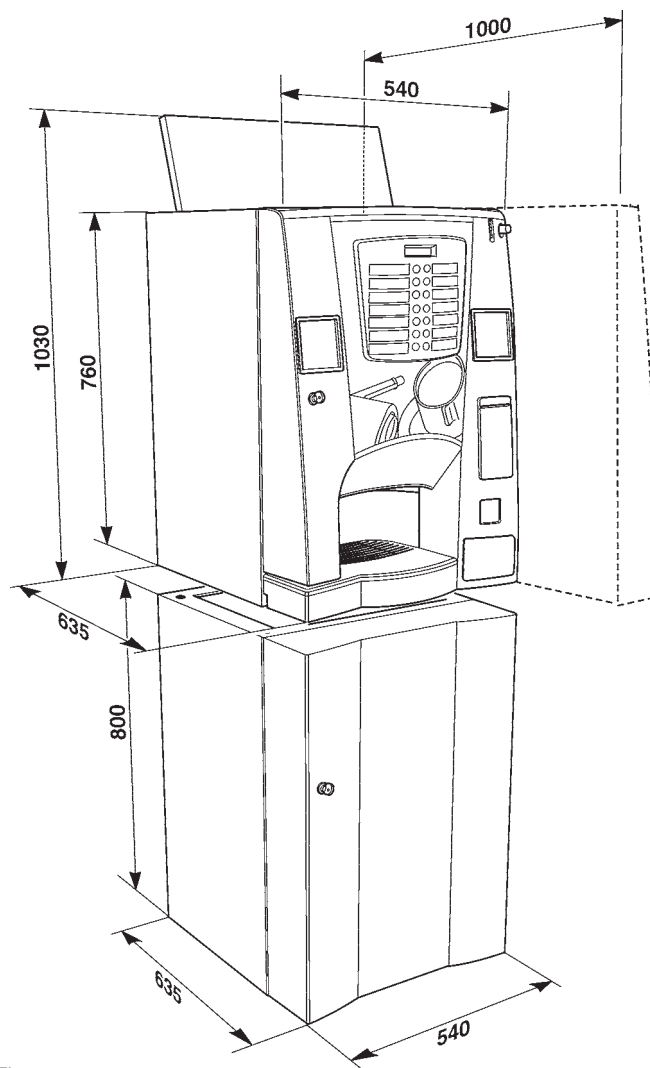

Fig. 2

Power supply voltage	120	V~
Power supply frequency	60	Hz
Installed power	1350	W

CUP DISPENSER

Suitable for cups with a rim diameter of 73-74 mm. with capacity of approximately 300 cups.

PAYMENT SYSTEM

The machine is supplied with all electrical prearrangement for systems with MDB, Executive and BDV protocol, as well as for installation of 24 V DC validators.

Beside the coin mechanism housing, suitable space is provided for the installation (optional) of the most widely used payment systems.

SALE PRICES

A different programmable price can be set for each single selection; the standard setting has the same sales price for all selections.

COIN BOX

Made from palstic (ABS). Cover and lock are available as accessories.

WATER SUPPLY

From the mains, with a pressure of 0.05 to 0.85 Mpa (0.5 - 8.5 bar).

The machine software is pre-set to control the water supply from an internal tank (optional kit).

AVAILABLE ADJUSTMENTS

Grade of grinding

Coffee and water doses by volume.

Temperature

Adjusted via software.

CONTROLS

- Presence of cups
- Presence of water
- Presence of coffee
- Position of coffee unit
- Liquid waste container empty
- Operating temperature reached

SAFETY DEVICES

- Door switch
- Manual-reset boiler safety thermostat
- Air-break float jammed
- Overflow solenoid valve
- Float for full liquid waste container
- Boiler sensor short-circuit/failure control

- Timer protection for:

- Pump
- Coffee unit ratiomotor
- Coffee dispensing
- Coffee grinder
- Cup column shift motor

- Overheating protection for:

- Doser units
- Coffee unit ratiomotor
- Coffee release magnets
- Pump
- Electric mixers
- Coffee grinder motor

- Fuse protection for

Electronic card and coin mechanism power supply transformer (primary and secondary windings)

CAPACITY OF CONTAINERS

Coffee beans	1.6	Kg
Ground coffee (decaffeinated)	0.45	Kg
Milk/Topping	1.3	Kg
French Vanilla	2.6	Kg
Chocolate	1.4	Kg
Sugar	2	Kg
Cups	300	

POWER CONSUMPTION

The machine power consumption depends on many factors, such as the temperature and ventilation of the room where it is installed, the inlet water and boiler temperature, etc.

With an ambient temperature of 22 °C the following power consumption levels resulted:

- to reach operating temperature: 75 Wh
- for 24 h in stand-by: 1569 Wh

The above power consumption calculated from average data should only be taken as an indication.

CHANGEABLE COMBINATION LOCK

Some machine models are fitted with a changeable combination lock.

The lock is supplied with one silver colour key, with standard combination, to be used for normal opening and closing.

The lock can be customised by means of a kit, available as accessory, permitting changing of the lock combination.

This kit includes a change key (black) for the standard lock combination as well as the change (gold) and use (silver) keys for the new combination.

Sets of change and use keys with other combinations can be supplied on request.

Additional sets of use keys (silver) may be requested, indicating the combination stamped on the keys.

Generally, only the use key (silver) is used, while the combination change keys (gold) can be kept as spares.

Do not use the change key for normal opening, as it may damage the lock.

To change combination do as follows:

- open the machine door to avoid forcing the rotation;
- lightly lubricate the inside of the lock with a spray;
- insert the current change key (black) and rotate to the change position (reference notch at 120°);
- remove the current change key and insert the change key (gold) with the new combination;
- rotate to the close position (0°) and remove the change key.

The lock will now have the new combination.

The keys with the old combination cannot be used for the new combination.

Fig. 3

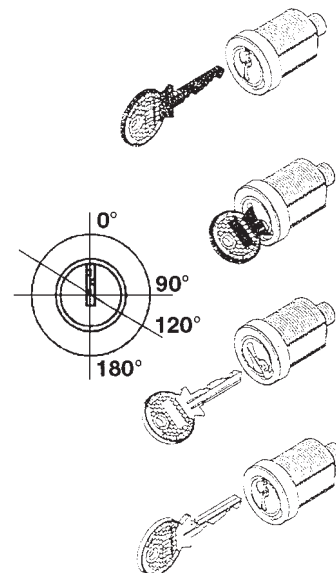

ACCESSORIES

A wide range of accessories can be installed on the machine to vary its performance.

The installation kits are supplied with their own installation and test instructions, which must be strictly observed to ensure the machine safety.

Installation and the following testing operations must be carried out exclusively by personnel who have a specific knowledge of the machine functions from a point of view of electrical safety and health regulations.

Chapter 1

LOADING AND CLEANING

The vending machine is not suitable for outdoor installation. It must be positioned in a dry room where the temperature remains between 2° C and 32° C, and not where water jets are used for cleaning (e.g. in large kitchens, etc.).

DOOR SWITCH

When opening the door a special switch disconnects the power from the machine electrical system to allow the operations described below, regarding loading and routine cleaning, in full safety.

All operations which require the machine to be energised with the door open must be carried out EXCLUSIVELY by qualified personnel who are aware of the specific risks of such condition.

CLEANING AND DISINFECTION

According to current safety and health rules and regulations, the operator of an automatic vending machine is responsible for the hygiene of materials that come in contact with foodstuff; therefore he must carry out maintenance on the machine to prevent the formation of bacteria.

At installation the hydraulic circuits and the parts in contact with foodstuff should be fully sanitised to remove any bacteria which might have formed during storage.

It is advisable that specific sanitising products are used for cleaning also the surfaces which are not directly in contact with foodstuff.

Some parts of the machine can be damaged by strong detergents.

The manufacturer declines all responsibility for damage caused by non-compliance with the above instructions or by the use of strong or toxic chemical agents.

Before starting any maintenance operations requiring parts of the unit to be removed, the machine must always be switched off.

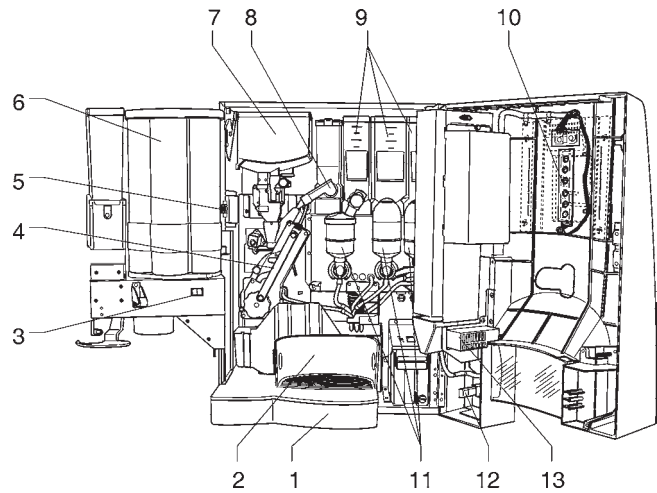

Fig. 4

- 1 - Liquid waste tray
- 2 - Dispensing compartment
- 3 - Cup release switch
- 4 - Coffee brewer unit
- 5 - Door switch
- 6 - Cup stacker
- 7 - Coffee canister
- 8 - Decaf coffee canister
- 9 - Instant prod. container
- 10 - Service buttons
- 11 - Instant prod. mixers
- 12 - Photocell
- 13 - Dispensing compartment lamp

USING THE VENDING MACHINES FOR HOT DRINKS IN OPEN CONTAINERS (Ex.: plastic cups, ceramic cups, jugs)

Vending machines for drinks in open containers should be used only to sell and dispense drinks obtained by:

- brewing products like coffee and tea;
- reconstituting instant and lyophilised products;

These products should be declared by the manufacturer as "suitable for automatic vending" in open containers.

The dispensed products should be consumed immediately. They should never be preserved and/or packed for later consumption.

Any other use is unsuitable and thus potentially dangerous.

CONTROLS AND INFORMATION

The user controls and information are located on the outside of the door (see Fig. 5).

The labels with the selection menu and instructions, supplied with the machine, must be inserted at the time of installation.

The Programming button, to access the machine functions, and the service button are located inside the machine on the right-hand side of the coin mechanism compartment.

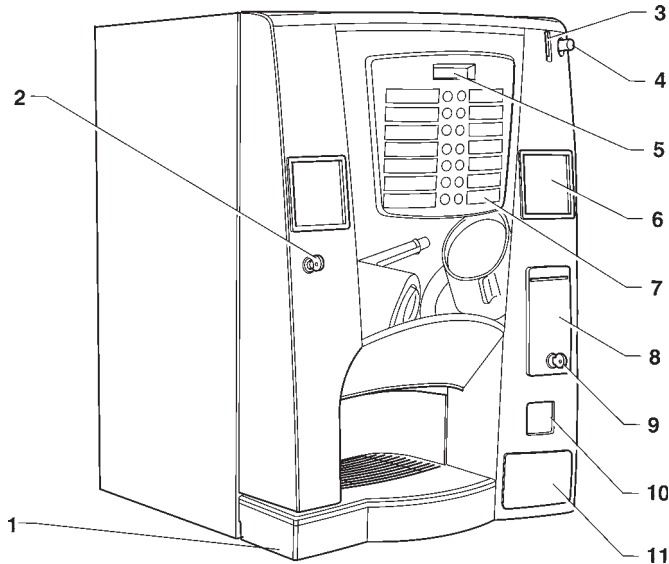

Fig. 5

- 1 - Liquid waste tray
- 2 - Lock
- 3 - Coin slot
- 4 - Coin return button
- 5 - Alphanumeric display
- 6 - Spaces for instruction labels
- 7 - Selection menu
- 8 - Prearrangement for front validator or labels
- 9 - Free vend and Jug facilities key
- 10 - Coin return
- 11 - Prearrangement for payment systems or labels

NOISE LEVEL

The continuous, weighted equivalent acoustic pressure level is below 70 dB.

LOADING CUPS

When loading cups for the first time (i.e. with the cup dispenser completely empty) do as follows:

- disconnect the electricity from the machine;
- rotate the shelf outwards, forcing the resistance of the small wheel;
- remove the cover from the cup container;
- fill the columns with cups, except the one aligned with the dispensing opening;
- switch the machine on and the full column will be positioned automatically over the dispensing opening;
- fill the empty column;
- release one or more cups with the special button and replace the cover.

The cup dispenser shelf has a double joint that improves access to the cup dispenser, especially when the machine is installed in a bank.

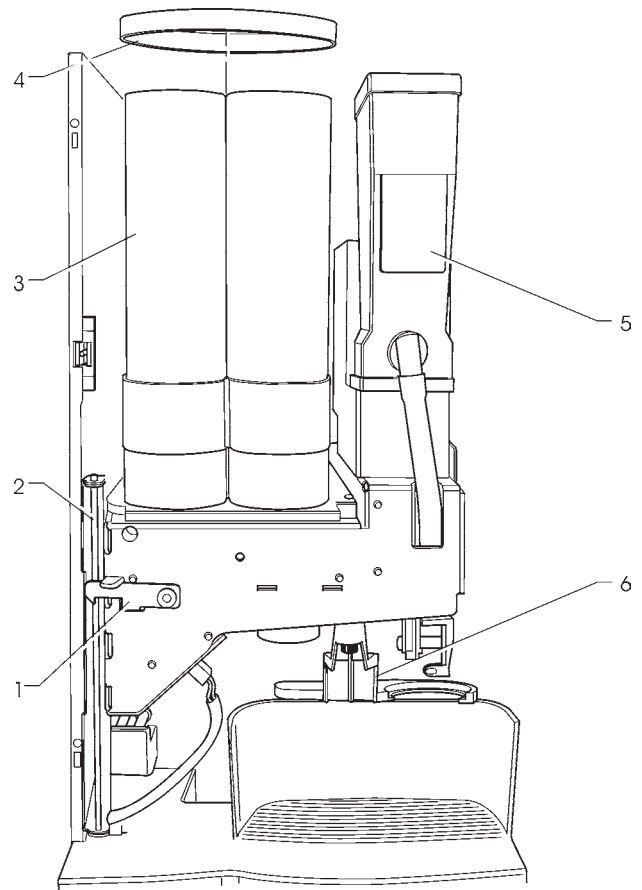

Fig. 6

- 1 - Shelf release lever
- 2 - Bracket hinge
- 3 - Cup stacker
- 4 - Lid
- 5 - Sugar container
- 6 - Cup shift arm

LOADING COFFEE

Lift the cover and fill the hopper with coffee, ensuring that the shutter is fully open (see Fig. 7).

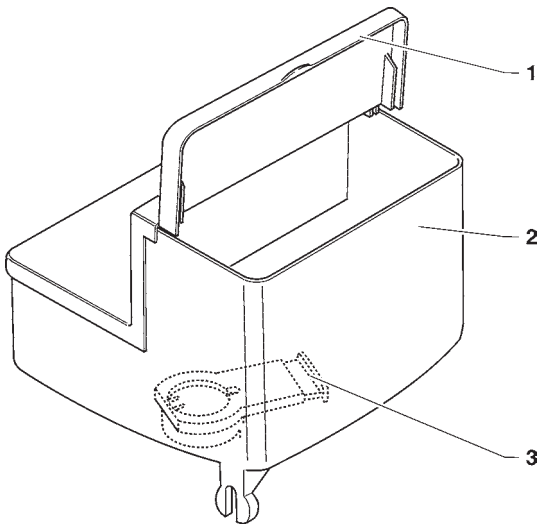

Fig. 7

- 1 - Lid
- 2 - Coffee canister
- 3 - Shutter

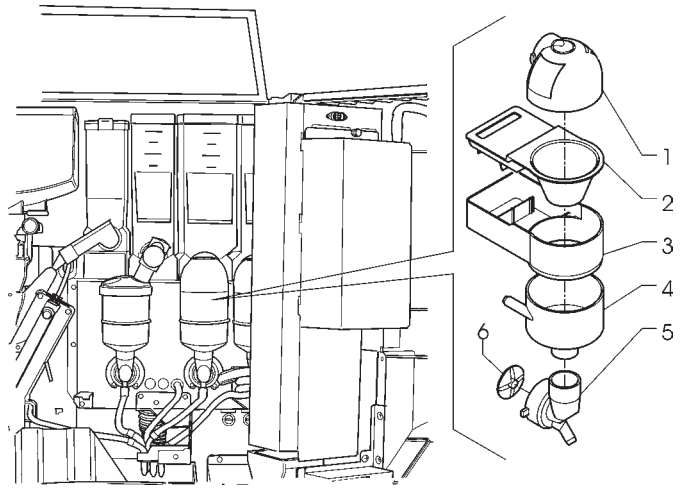

Fig. 8

- 1 - Powder feeder
- 2 - Powder funnel
- 3 - Powder deposit drawer
- 4 - Water funnel
- 5 - Mixer feeder
- 6 - Mixer impeller

LOADING SUGAR AND INSTANT PRODUCTS

A self-adhesive label indicating the product is attached on each container.

After lifting their cover, fill the single containers with the appropriate products, taking care not to compress them to prevent packing. Make sure the products do not contain any clots.

SANITISING THE MIXERS AND THE FOODSTUFF CIRCUITS

When installing the machine, and then at least once a week or even more frequently according to the use of the machine and the quality of the inlet water, the mixers and the dispensing conduits must be thoroughly sanitised (cleaned and disinfected), to guarantee proper hygiene of the dispensed products.

The parts to be cleaned are as follows:

- powder deposit drawers, mixer and instant drink dispensing conduit;
- dispensing tubes and spouts;
- sugar chute;
- dispensing compartment;
- remove the powder and the water funnels, the feeders, the powder deposit drawers and the mixer wheels from the mixers (see Fig. 8);

- in order to unscrew the wheels, simply block the disk fitted on the mixer shaft with a finger;

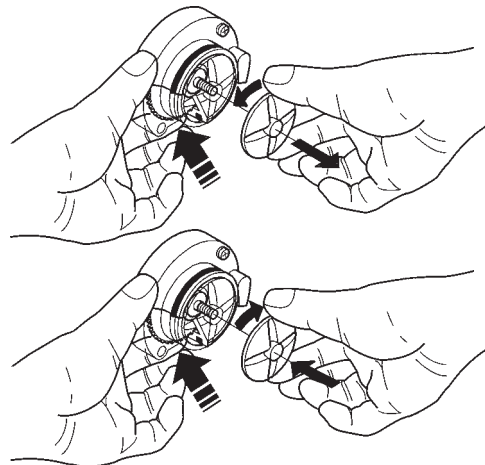

Fig. 9

- wash all parts with detergent (using the doses indicated by the manufacturer) being sure that all visible residue and product layers are mechanically removed, using a brush if necessary;

Disinfection should be carried out using sanitising products.

- soak all components for approx. 20 minutes in a container filled with the previously prepared sanitising solution;
- reinstall the feeders and the water funnels;
- reinstall the powder deposit drawers and the powder funnels after thoroughly rinsing and drying them.

After reinstalling all parts the following is however required:

- enter into "Filler" mode to clean the mixers (see relevant paragraph) and add a few drops of the sanitising solution in the various funnels.
- After disinfection thoroughly rinse all components to ensure that all residue of the detergent solution is removed.

CLEANING THE WATER SUPPLY TANK

(OPTIONAL)

For machines equipped with a water tank inside the support cabinet, at least once a week, such tank must be sanitised with the sanitising product used for the mixers.

CLEANING THE WASTE TRAYS

The coffee grounds trays and dispensing compartment can be removed easily for emptying and cleaning.

The coffee waste tray can be removed only with the door open; the dispensing compartment tray can be removed also with the door closed.

In order to remove the dispensing compartment tray, lift it slightly and pull towards the front of the machine, making sure to move it to the right to allow its tail to come out from the door zone.

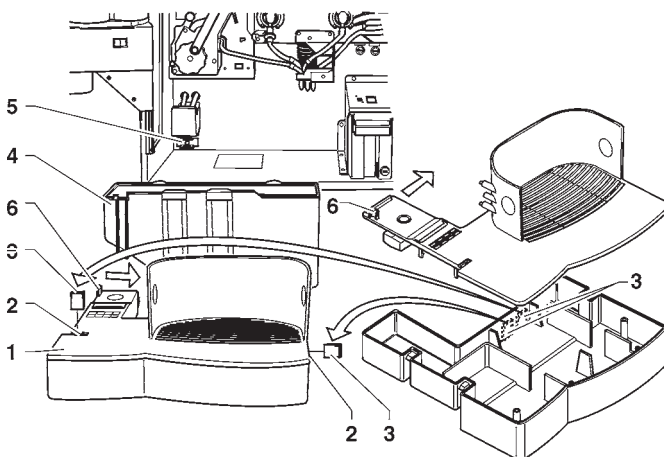

Fig. 10

- 1 - Dispensing compartment drip tray
- 2 - Inserts seats
- 3 - Withdrawal prevention inserts
- 4 - Coffee waste tray
- 5 - Tray detection switch
- 6 - Tray tail

The inserts, located inside the dispensing compartment tray, when inserted into place prevent removal with the door closed.

For safety reasons, when removing the trays, special switches disconnect the power from the machine and signal the absence of the tray to the control software.

CLEANING THE CUP SHIFT ARM

The cup shift arm must be cleaned periodically by removing it from the machine. In order to remove it, completely undo the fastening knurled nut (see Fig. 11).

When reinstalling it, ensure that the spacer washer is positioned correctly.

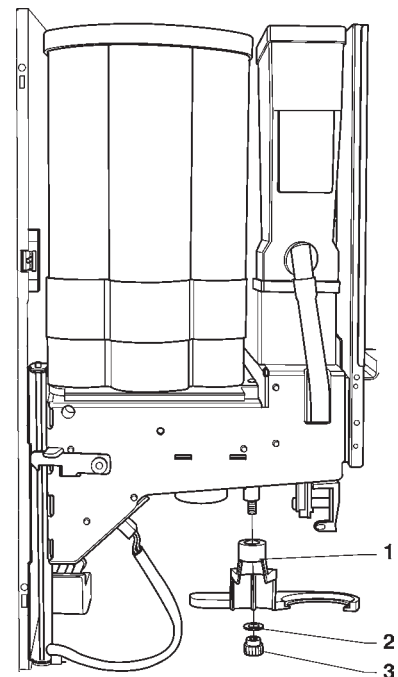

Fig. 11

- 1 - Cup shift arm
- 2 - Spacer washer
- 3 - Knurled nut

CLEANING THE SUGAR DISPENSER

For models with sugar dispensed directly into the cup, the sugar dispensing system must be cleaned periodically using hot water (see Fig. 12) proceeding as follows:

- release the return spring;
- lift the flexible lever to free the pin;
- remove the pin and the dispensing spout;
- wash and dry thoroughly;
- after cleaning, reinstall all parts in the reverse order.

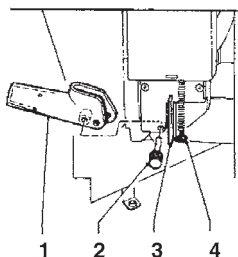
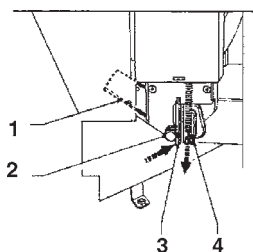

Fig. 12

- 1 - Sugar dispensing spout
- 2 - Pin
- 3 - Flexible lever
- 4 - Return spring

PERIODIC CLEANING THE COFFEE UNIT

Every time coffee is refilled, or at least once a week, any powder residue should be removed from the external parts of the coffee unit, particularly from the coffee funnel.

SUSPENDING FROM USE

If for any reason the machine is switched off for a period exceeding the use-by date of the products, the following will be necessary:

- completely empty the containers and thoroughly wash them with the sanitising products used to clean the mixers;
- completely empty the dosing grinder by dispensing coffee until the empty condition is indicated.
- completely empty the boiler and the air-break, loosening the clamp on the special hose.

Chapter 2 INSTALLATION

Installation and the following maintenance operations should be carried out with the **machine switched on** and therefore by qualified personnel only, who are trained in the correct use of the machine and informed about the specific risks of such situation.

To energize the system with the open door, simply insert the special key into the slot (see Fig. 13 - 2).

The door can be closed only after removing the yellow key from door switch and lowering the machine top panel.

The machine must be installed in a dry room with temperature between 2° C and 32° C.

At installation the hydraulic circuits and the parts in contact with foodstuff should be fully sanitised to remove any bacteria which might have formed during storage.

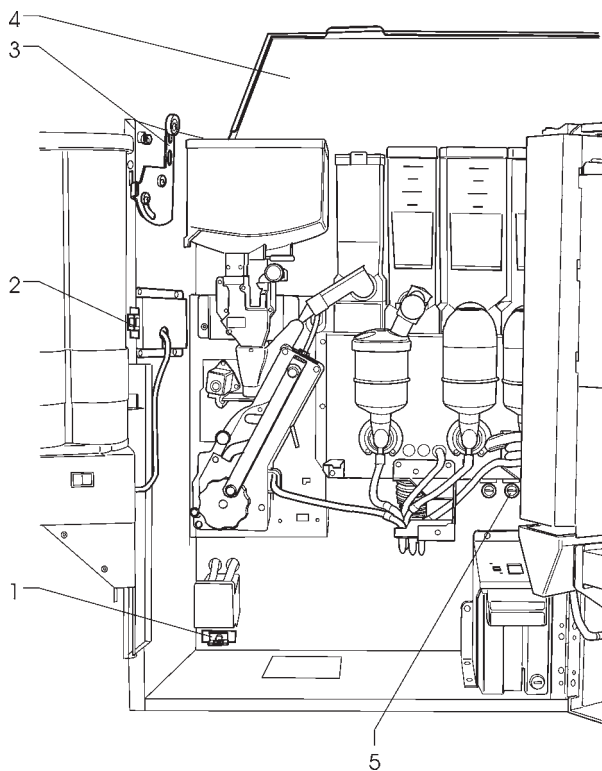

Fig. 13

- 1 - Tray detection switch
- 2 - Door switch
- 3 - Top panel closing control device
- 4 - Lift-up top panel
- 5 - Network fuses

DOOR SWITCH

When opening the door a special micro-switch disconnects the power from the machine electrical system.

To energize the system with the open door, simply insert the special key into the slot (see Fig. 13).

With the door open, there is no access to energised parts. Inside the machine, the only parts that stay energised are those protected by covers and carrying a plate with the warning “Disconnect the power before removing the protective cover”.

Before removing such covers disconnect the power supply cable from the grid.

The door can be closed only after removing the key from door switch and lowering the machine top panel, so that the closing control device is triggered.

UNPACKING THE VENDING MACHINE

After removing the packing, ensure that the machine is intact.

If in doubt do not use the machine.

No packing elements (i.e. plastic bags, polystyrene foam, nails, etc.) should be left within the reach of children, as they are potentially dangerous.

Packing materials must be disposed of in authorised containers and the recyclable ones must be recovered by qualified companies.

Important notice!!

The machine should be positioned with a maximum inclination of 2°.

If necessary provide proper levelling by way of the adjustable feet included (see Fig. 14).

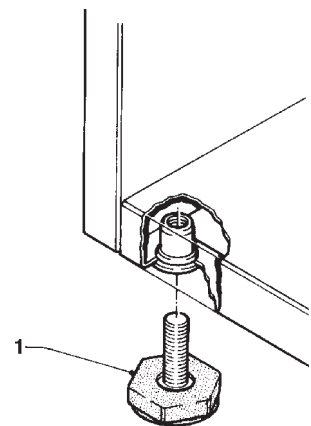

Fig. 14

- 1 - Adjustable foot

INSERTING THE PRODUCT LABELS

Undo the fastening screws and remove the cover. The product should be inserted into the special slots (see Fig. 15).

According to the model, some buttons may not be used (refer to the selection dose table).

The machine is supplied also with the self-adhesive labels to be attached to the product containers according to the layout (refer to the selection dose table).

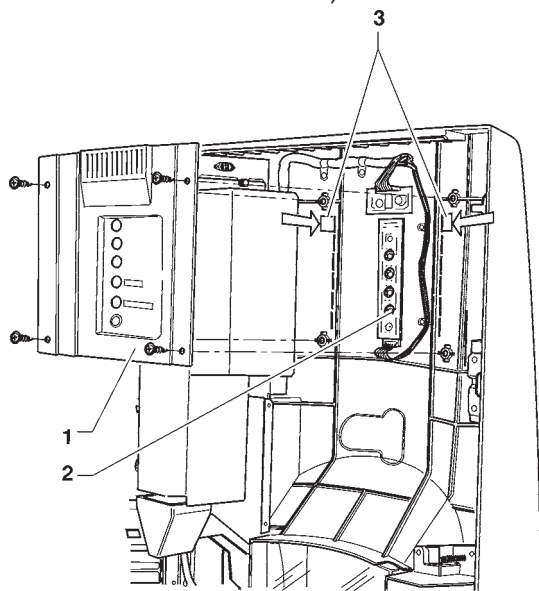

Fig. 15

- 1 - Board cover
- 2 - Programming access button
- 3 - Selection labels

CONNECTING THE MACHINE TO THE WATER MAINS

The machine must be connected to the drinking water mains, taking into account law provisions in force in the country where the machine is installed.

The water pressure must be 0.05 to 0.85 MPa (0.5 - 8.5 bar). Run some water from the mains until it is clear and without impurities.

Use a hose capable of withstanding the water mains pressure and suitable for use with foodstuff (min. inside diameter of 6 mm) to connect the water supply to the fitting (3/4" gas) of the water inlet solenoid valve (see Fig. 16).

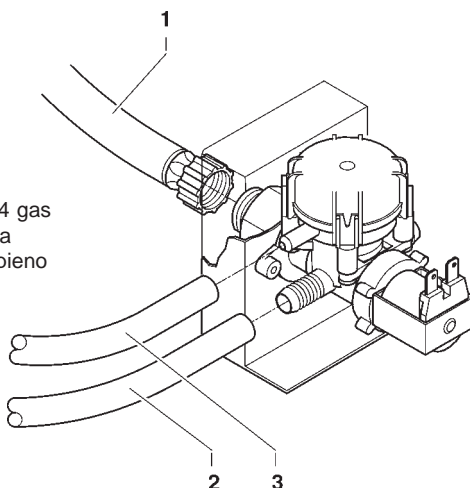

Fig. 16

- 1 - Tubo entrata 3/4 gas
- 2 - Tubo di mandata
- 3 - Tubo di troppo pieno

It is good practice to install the water supply tap outside the machine in an easily accessible position.

OVERFLOW DEVICE

The water inlet solenoid valve (see Fig. 16) is equipped with an overflow device which mechanically stops the water inlet if there is a malfunction in the solenoid valve or in the boiler water level control device.

To restore normal operation, proceed as follows:

- disconnect the electricity from the machine;
- drain the water contained in the overflow hose;
- shut off the water supply using the tap outside the machine;
- loosen the nut which secures the solenoid valve supply hose to relieve the water mains residual pressure and then tighten again (see Fig. 16);
- open the tap and switch the machine on.

WATER SOFTENER UNIT

The machine is sold without water softener. Should the water be very hard, a water softener unit can be installed.

The water softener, available as accessory, must be replaced or regenerated regularly following the directions from the manufacturer.

CONNECTING THE MACHINE TO THE POWER SUPPLY

The machine is designed to operate under single-phase 120 V~ voltage and is protected by 15 A fuse.

Do not connect the machine to a circuit operating at more than 150 V to ground.

Before making the connection, ensure that the rating corresponds to that of the power grid, and more specifically:

- the supply voltage rating must be within the range recommended for the connection points;
- the main switch should be capable of withstanding the peak load required, and at the same time ensure proper omnipolar disconnection from the power grid with an opening gap of the contacts of at least 3 mm.

The switch, the power outlet and the plug must be located in an easily accessible position.

The electrical safety of the machine is ensured only when it is correctly earthed according to the safety standards in force.

This fundamental safety requirement must be duly verified, and if in doubt the system must be carefully tested by qualified technicians.

The power supply cable is of the type with a fixed plug. Any replacement of the power supply cable (see Fig. 17) should be made by qualified personnel only, using cables of the type UL SJT 3x16 AWG.

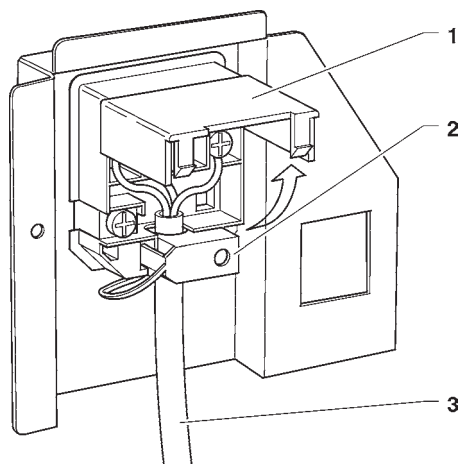

Fig. 17

- 1 - Lift cover
- 2 - Cable clamp
- 3 - Cable from the mains

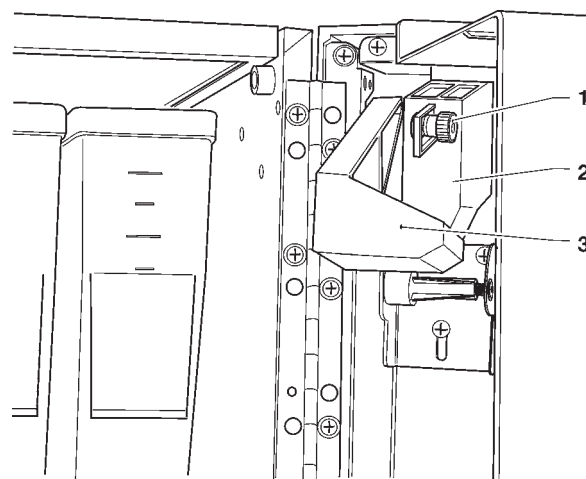

Fig. 18

- 1 - Lever adjustment screw
- 2 - Coin chute
- 3 - Coin return lever

Do not use adapters, multiple sockets and/or extensions.

Before switching the machine on, be sure it is correctly connected to the water mains and the cut-off valve is open.

THE MANUFACTURER DECLINES ALL RESPONSIBILITY FOR ANY DAMAGE CAUSED BY NON-COMPLIANCE WITH THE ABOVE MENTIONED PRECAUTIONS.

INSTALLING THE PAYMENT SYSTEM

The machine is sold without payment system, therefore the installer of such a system has sole responsibility for any damage to the machine or to things and persons caused by incorrect installation.

Install the coin mechanism paying attention, according to the type used, to:

- secure the coin mechanism onto the support, choosing the most suitable securing holes;
- open the board support removing the two fastening screws;
- loosen the fastening screw and adjust the coin slot chute according to the coin mechanism opening;
- loosen the fastening screws and adjust the coin return lever.

FILLING THE WATER SYSTEM

If the machine indicates the no-water condition inside the boiler after the machine has been switched on, an installation cycle will automatically be started, and namely:

- the message "INSTALLATION" will be shown on the display for the entire duration of the cycle;
- the coffee solenoid valve is opened so that the air may be bled from the boiler and 960 cc. of water filled.

N.B.: If there is no water flow from the mains during the installation cycle, the machine will be blocked until the water is resumed or the machine is switched off.

This operation must be carried out manually, using the special function from the "test" menu in "Technician" mode, if the **kit (optional) for water supply from an internal tank is fitted** or after any **maintenance** requiring the boiler to be emptied but not the air-break.

INSTALLATION IN A BANK OF MACHINES

The machine control system is pre-arranged for the connection in a bank of vending machines using special kits.

This permits the use of a single payment system and remote connection (GSM) for more machines.

In the event of installation in a bank of machines, it can be configured a "Master", i.e. having control over the second machine, or as "Slave", i.e. leaving the control to the other machine.

COFFEE UNIT OPERATION

COFFEE DISPENSING CYCLE

After each time the machine is switched on, the coffee unit is rotated completely before the normal cycle to ensure that the device is in the correct start position.

When making a coffee selection, during the coffee grinder operation the unit rotates 180° to bring the brewing chamber into a vertical position (see Fig. 19).

The coffee grinder operates until filling the coffee doser chamber.

When the doser unit is full, the ground coffee dose is released into the coffee unit.

The coffee falls into the vertical brewing chamber (1) (see Fig. 19).

The ratiomotor handle engaged with the disk (2) located outside of the assembly rotates by 180°, making the brew chamber swing and lowering the upper piston (3) (see Figure 20).

Due to the water pressure, the pre-brewing spring (5) sinks and the lower piston (4) goes down 4 mm, thus forming a water cushion which allows an even use of the coffee dose. At the end of the dispensing cycle and during a pause of 3 seconds, the pre-brewing spring (5) will discharge the water through the third way of the dispensing solenoid valve, lightly pressing the used coffee dose.

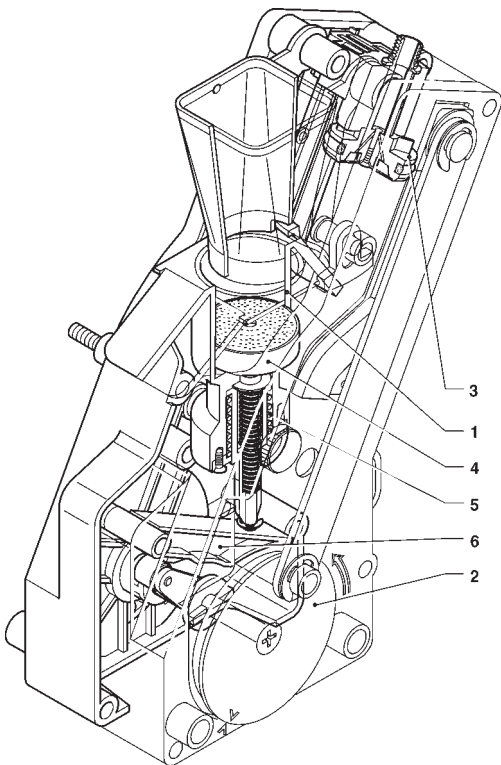

Fig. 19

- 1 - Brewing chamber
- 2 - External disk
- 3 - Upper piston
- 4 - Lower piston
- 5 - Pre-brewing spring
- 6 - Swinging lever

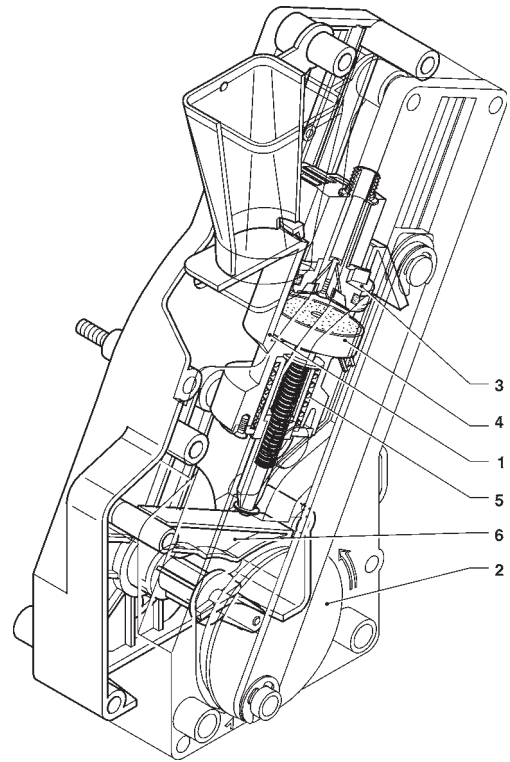

Fig. 20

- 1 - Brewing chamber
- 2 - External disk
- 3 - Upper piston
- 4 - Lower piston
- 5 - Pre-brewing spring
- 6 - Swinging lever

By completing its rotation, the ratiomotor makes the swinging lever (6) lift the pistons and the coffee dose.

At the same time, when the brewing chamber returns to its vertical position, the scraper on the coffee hopper stops the used coffee dose and drops it.

The lower piston now returns to the top dead centre.

CHECKING AND ADJUSTING THE MACHINE SETTINGS

To get the best results from the product used, the following should be checked:

That the used coffee dose is lightly compressed and damp.

The grade of grinding of ground coffee.

The dose weight of the instant products.

The drink temperature.

The water dose.

Should the standard settings need to be changed, proceed as indicated in the next sections of this manual.

The weight of instant products, the water dose and temperature are directly controlled by the microprocessor.

To adjust them it is therefore necessary to follow the programming procedures.

STANDARD SETTINGS

The vending machine is supplied with the following settings:

- coffee temperature (at the spout) approx. 85-89°C;
 - instant product temperature (at the spout) 75°C approx.;
- The machine standard settings assign the same price, expressed in number of basic coins, to all selections.

ADJUSTING THE BREWING CHAMBER VOLUME

When the upper piston is correctly positioned, the coffee unit can operate with coffee doses of 5.5 to 10.5 g.
To change the piston position (see Fig. 21) do as follows:

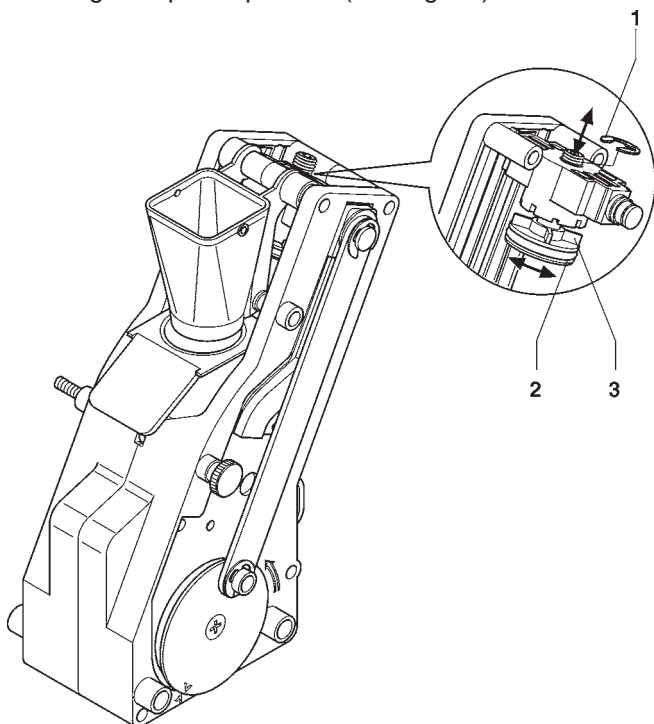

Fig. 21

- 1 - Snap ring
- 2 - Upper piston
- 3 - Reference fins

- remove the snap ring from its seat;
- place the piston in the proper adjusting notches:
 - .less deep notches for 5.5 to 8.5 g doses;
 - .deeper notches for 7.5 to 10.5 g doses.

ADJUSTING THE GRADE OF GRINDING

When a variation in the grade of grinding is desired, turn the relevant adjusting knob on the grinder (see Fig. 22) and more specifically:

- turn the knob anticlockwise for coarser grinding;
- turn the knob clockwise for finer grinding.

For optimum results, it is advisable to vary the grade of grinding with the coffee grinder motor running.

NB: After adjustment of the grade of grinding, at least 2 test selections must be performed in order to check the new grade of grinding for ground coffee:

The finer the grade of grinding the longer the time necessary for dispensing the coffee and vice versa.

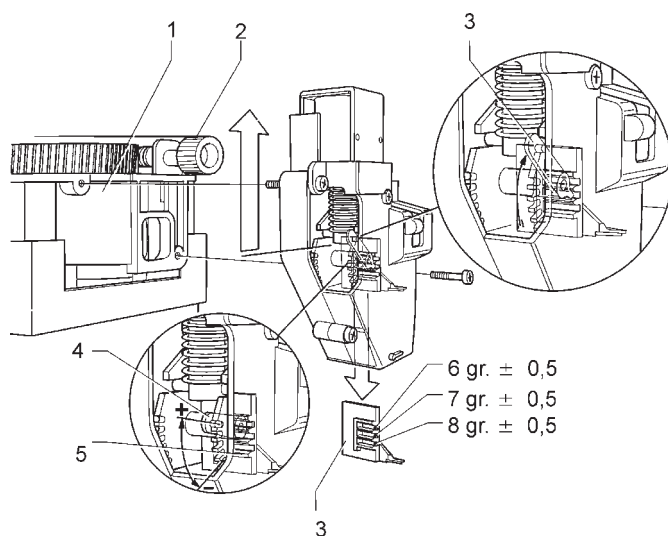

Fig. 22

- 1 - Coffee grinder
- 2 - Grinding adjusting knob
- 3 - Dose regulator
- 4 - Dose adjusting lever
- 5 - Reference notches

ADJUSTING THE COFFEE DOSE

The dose adjusting lever can be positioned in one of the 6 reference notches bearing in mind that:

- the dose is increased by lifting the lever;
- the dose is reduced by lowering the lever;
- every notch changes the dose by approx. 0.25 g.

In addition, when the lever is fully rotated upwards, the ratchet can be released from the groove in the dose regulator (see Fig. 20) and replaced into a different groove to change the average dose setting to:

- low 6 g. ± 0,5
- medium 7 g ± 0,5
- high 8 g ± 0,5

To take the dose just remove the coffee unit and use the special function from the "Test" menu in "Technician" mode (see relevant section).

Important notice!!!

To refit the coffee unit, pay special attention to the piston position. Reference notches on the external disk and on the unit case should match (see Fig. 24).

WATER TEMPERATURE CONTROL

The boiler temperature is controlled by the software and can be adjusted directly from a menu.

Notes on programming

The machine electronic control allows or not the use of many functions:

All of the available functions are described in the machine program, including the ones that are not used for the specific configuration of the model (layout).

The machine is supplied with a dose table, describing the different functions and layouts available for the specific model and the flowchart of the programming menu.

Below is listed a summary explanation of the main functions useful for managing the operation of the machine, not necessarily in the order in which they are displayed in the menu.

For further information and detailed explanations refer to the programming manual available through our sales organisation, at our after-sales service.

The software version can be updated using the specific systems (PC, Flash, UpKey etc.).

The messages on the display that indicate the current operation

are fixed, while any action required by the user is blinking.

POWER ON

When closing the door, the display indicates the software version number to which referring for consulting the programming manual. The machine can be programmed for displaying, for a few second, the number of selections made.

After a few seconds the display shows the message: and the machine goes into normal operating mode

Brio 3 ES
REV 1.0 UL

OPERATING MODES

The machine can be in three different operating modes. According to the operating mode, the buttons take on different functions.

The available operating modes are as follows:

FUNCTIONS

Normal operating mode	Coins accepted products dispensed
Filler menu	Test dispensing machine maintenance
Technician menu	Programming different parameters

NORMAL OPERATING MODE

During the normal operating mode the display shows the message for the user with the prompt to select the drink. The function of the buttons can be different according to the layout and to the choices made during programming.

SELECT THE DRINK

When inserting coins or a payment system, the available credit is displayed.

SELECT THE DRINK
Credit= 0.50

During the drink dispensing, also a status bar is shown, indicating the drink preparation status.

DRINK SELECTED
■■■■■■■■

In the event of a malfunction detected by the control system, an error message will be displayed indicating the type of problem.

SELECTION NOT AVAILABLE
"Failure name"

At the end of dispensing, the display indicates for a few seconds the request to pick up the drink and the machine is preset for the next selection.

DRINK READY
TAKE

SURFING MODE

The interaction between system and user occurs through the following components:

- Liquid crystal display (LCD) 2 lines of 16 characters.
- External direct selection push-button panel which takes on the following functions when in "Filler" and "Technician" mode (see Fig. 23):

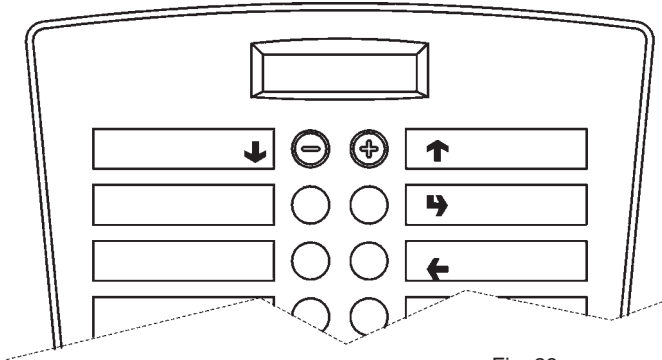

Fig. 23

Scrolling buttons "↑" and "↓":

To move to the next or previous menu option and change the values (up or down).

Confirm button "→":

To go from a menu to a sub-menu, or to confirm the information on the display.

Exit button "←":

To move back from a sub-menu to the higher level menu, or used to cancel the current information on the display. It is also used for going from "Technician" mode to "Filler" mode and vice versa.

FILLER MENU

When pressing once the programming button (see Fig. 15) located on the inside of the door, the machine goes into "Filler menu" mode.

The display presents the first item of the "filler" menu with a series of numbers next to it, identifying the level of the current menu.

Press the confirm button "→" to access the menu.

Press the exit button "←" to return to the previous menu.

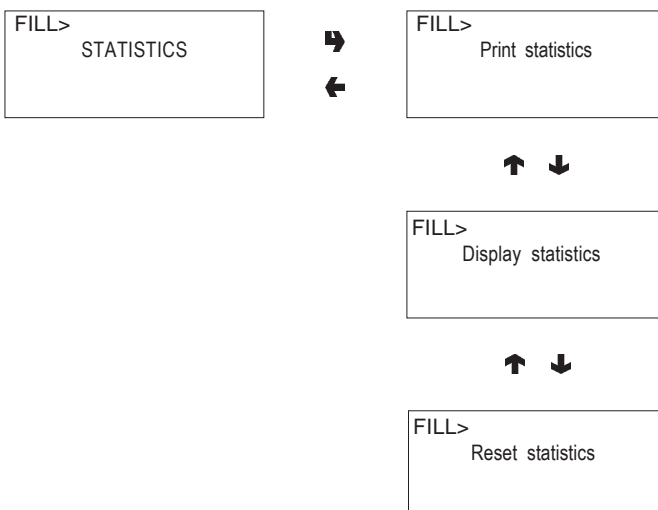

STATISTICS

All data concerning sales and the machine operations is stored in both total counters and relative counters, which can be reset without losing total data.

Print

Connect an RS232 serial printer having a Baud rate of 9600, 8 data bit, no parity, 1 stop bit to the serial port located on the push button board to print all of the statistics.

The printout will also contain the machine information, the date and the software version.

To connect the printer, do as follows:

- press the confirm print button "→", displaying the message "Confirm?";
- connect the printer before confirming;
- press the confirm button "→" to start printing.

Display

Press the confirm button "→" to display in a sequence the same data obtained with the statistic printing, for both total and relative counters.

Cancel

Statistics can be reset for relative counters globally (all types of data) or selectively for:

- selections
- failures
- coin mechanism data

Press the confirm button "→", and the message "Confirm?" starts blinking.

Press the confirm button "→", the message "Working" is displayed for a few seconds and all statistics are reset.

SELECTION PRICES

This function is used for changing the sales price for each single selection and for each time band that may be set.



CHANGETUBES CONTROL

By accessing the “Tube control” function the change tubes can be filled or released manually.

Confirm refilling, and the display will indicate “Credit: —” which is the value of money available in change the tubes; insert the desired coin into the validator and the display will indicate the value of money available in the change tubes.

When confirming releasing, it will be possible to decide which tube to release. Each time the confirm button “➡” is pressed, a coin is ejected from the active tube.

FILL>
Tubes control



Fill tubes
Credit: #####

Release tubes



Release tubes
Tube A ÷ D

DISPLAYING THE TEMPERATURE

With this function it is possible to read the boiler temperature directly in °C.

FILL>
Boiler temperature



Boiler temperature
T. = ##.# °C

TEST DISPENSING

For complete or partial dispensing tests (water, powder, only and without accessories) each button (or combination of buttons according to the model) is assigned a selection (see the dose selection table).

N.B. For espresso coffee based selections, only the additions are dispensed with the partial dispensing of powder and water; if a selection requires no addition the message “Sel. disabled”, indicating a disabled selection, will be displayed.

FILL>
TEST



FILL>
Complete selection



FILL>
Water only



FILL>
Powder only



FILL>
No accessories



FILL>
Accessories only

GSM PRE-ALARMS

The control software can send, via GSM modem, a signal indicating an “ending product” signal, when there is only a certain (programmable) number of pieces or grams of powder of a given product left. With this function the counters that control the pre-alarms are reset.

FILL>
GSM



FILL>
Reset pre-alarm counters

EVADTS TRANSFER

When activating this function, the machine awaits the connection with a device to acquire the EVADTS statistics.

FILL>
EVADTS



FILL>
Connection

FILLER MENU MASKING

The functions described in this chapter can be inhibited selectively from the “technician menu”.

TECHNICIAN MENU

Below is listed a summary explanation of the main functions useful for managing the operation of the machine, grouped by use logic and not necessarily in the order in which they are displayed in the menu.

The software version can be updated using the specific systems (PC, Flash, Upkey etc.), therefore all is described in this chapter is only to be taken as an example.

For further information and detailed explanations refer to the dose selection table supplied with the machine and to the programming manual available through our sales organisation, at our after-sales service, referring to the version number that is displayed when switching on the machine. When pressing once the programming button located on the coin mechanism compartment, the machine goes into "Filler menu" mode.

When pressing button "←" from "Filler" mode, the machine is preset to "Technician menu".

Note:

When pressing button "←" from "Technician" mode, the machine returns to "Filler menu" mode.

The first option of the programming menu is displayed, enabling the following functions:

FAILURES

The machine is equipped with various sensors for monitoring the different functional units.

When a malfunction is detected, a failure is "indicated" and the machine (or part of it) is placed out of service. The failure is stored in the appropriate counters.

The failure monitored by the software may regard functional units not present in the specific model; they are in any case listed when scrolling the menu.

The possible failures are indicated in the following cases:

READING PRESENT FAILURES

When the "Failure" function is displayed, press the confirm button "→" to display the present failures.

If no failures are currently present, after pressing the confirm button "→" the message "End failures" will be displayed.

The possible failures are indicated in the following cases:

Water failure

If the air-break micro-switch is closed for a certain time, the water inlet solenoid valve will remain energized until the water flow is restored; if the model is fitted with a water supply tank, the pump is switched off.

Waste container full

This occurs after the liquid waste container float is triggered.

Air-break

The machine will lock if after a certain number of volumetric counter pulses the lack of water has not been signalled.

No cups in the dispenser

When the empty cup stack micro-switch opens, the stack shift motor is activated. If after one full turn of the cup dispenser the micro-switch is not closed the machine locks.

Volumetric counter

Failed computation of the volumetric counter within a maximum given time.

Boiler

The machine will lock if after 10 minutes of heating from the machine start, or from the last selection, the boiler fails to reach the operating temperature.

Machine control board

Failed dialogue between C.P.U. board and machine control board.

Coin mechanism

The machine is locked if it receives a pulse longer than 2 seconds on a validator line or the communication with the serial coin mechanism does not take place for more than 30 seconds (Executive protocol) or 75 seconds (BDV protocol).

Coffee release

If after releasing the ground coffee dose the micro-switch of the coffee doser unit indicates the presence of coffee in the dosing chamber, all coffee-based selections are disabled.

Espresso unit

Due to mechanical blocking of the unit. The machine is not locked, but all coffee-based selections are disabled.

No coffee

If after a period of 15 seconds of grinding coffee a dose is not obtained, all coffee-based selections are disabled.

RAM Data

One or more areas of the RAM contain wrong data which was corrected with the default values.

The machine will continue to function, but it would be advisable to initialise as soon as possible.

Cup release

If the cup sensor (optional) does not detect any objects in the dispensing compartment twice in a row, the machine can be locked or left enabled for dispensing in a mug.

Capsule lock

Not used in these models

FB piston

Not used in these models

FB scraper

Not used in these models

RESET

By confirming this function all current failures will be reset



PROGRAMMING PARAMETERS

CASH

This set of functions controls all parameters regarding the payment systems and the sales prices.



SELECTION PRICES

Four different prices can be set for each selection according to the programmed time bands for when the time table option is enabled.

For each of the 4 time bands prices (0 to 65,535) can be programmed globally (same price for all selections) or for the single selections.

Should the majority of products be sold at the same price, it will be convenient to set the price globally and then change the figure of the selections with different prices.

Time bands

Four programmable time bands are provided for selling products at different prices.

The time periods are programmable for beginning and end time by hours (00 to 23) and minutes (00 to 59).

If the values for start and end of the time band are set to 00.00 the time period is disabled.

The reference time is kept by an internal clock, programmable as:

day/month/year week-day 1-7

and then

hour/minutes/seconds.

If the values for start and end of the time band are set to 00.00 the time period is disabled.

COIN MECHANISMS

It is possible to decide which of the payment system protocols available are to be enabled for the functions.

The available payment systems are:

- Validators
- Executive
- BDV
- MDB

By selecting one of the systems it is possible to control its functions.

MDB

The MDB protocol menus are used for defining the following functions:

Type of vending

Setting the operating mode for multiple or single dispensing. With multiple dispensing, the change is not automatically returned after a successful selection; however the credit is available for further selections. When pressing the coin return button (if the function is enabled), the available credit is returned up to the maximum change value.

Credit control

To enable/disable the operation of the coin return button.

Maximum credit

This function is used to define the maximum accepted credit.

Maximum change

It is possible to set a limit to the total amount of change returned by the coin mechanism when pressing the coin return button or after a single dispensing serving.

Any credit exceeding the amount programmed with this function will be cashed.

Accepted coins

It is possible to define which, among the coins recognised by the validator, are to be accepted when the change tubes are full.

Check the coin mechanism configuration for the correct coin to value matching.

Returned coins

It is possible to define which, among the coins available in the tubes, are to be used for returning the change. This parameter is active only with coin mechanisms that do not automatically control the choice of tube to be used (Auto changer payout).

Check the coin mechanism configuration for the correct coin to value matching.

Accepted bills

It is possible to define which, among the bills recognised by the reader, are to be accepted.

Check the reader configuration for the correct bill to value matching.

Minimum level of tubes

This function is used for setting the number of coins (0 to 15) to determine the status of full change tubes and the "Insert exact amount" message for the user.

Accepted coins with "exact amount"

It is possible to define which, among the coins recognised by the validator, are to be accepted when the machine is in the "exact amount" condition.

Check the coin mechanism configuration for the correct coin to value matching.

Accepted bills with "exact amount"

It is possible to define which, among the bills recognised by the acceptor, are to be accepted when the machine is in the "exact amount" condition.

Check the acceptor's configuration for the correct bill to value matching.

EXECUTIVE

The following payments systems are available for the Executive system:

- Standard
- Price Holding
- Coges
- U-Key
- Sida

VALIDATORS

When the "Validat.Lines" (line setting) function of the "Technician" menu is displayed, the value of the 6 validator coin lines can be changed.

BDV

The BDV protocol menus are used for defining the following functions:

Type of vending

Setting the operating mode for multiple or single dispensing. With multiple dispensing, the change is not automatically returned after a successful selection; however the credit is available for further selections. When pressing the coin return button, the available credit is returned if its value is lower than the maximum change value.

Credit control

This function enables/disables the return of credit if no selections are made.

If enabled, this function allows the return of coins even if the first selection was not dispensed.

If however a selection fails for any reason, the change will be returned if requested.

Maximum credit

This function is used to define the maximum accepted credit.

Maximum change

It is possible to set a limit to the total amount of change returned by the coin mechanism when pressing the coin return button or after a single dispensing serving.

Any credit exceeding the amount programmed with this function will be cashed.

Accepted coins

It is possible to define which, among the coins recognised by the validator, are to be accepted.

Check the label on the coin mechanism for the correct coin to value matching, indicating the position of the coins.

Non accepted coins

This function programs the rejection of coins when in "exact amount" mode.

Check the label on the coin mechanism for the correct coin to value matching, indicating the position of the coins.

Dispensing buttons

This function enables or not the buttons on the coin mechanism used to release the coins in the change return tubes.

Value of "exact amount"

This value defines the combination of empty coin tubes, setting the coin mechanism in "exact amount" mode. The possible combinations of empty coin tubes are indicated below.

For greater simplicity, the combination is described with reference to tubes A, B and C, where tube A receives the lower value coins and tube C the greater value coins.

0	=	A or (B and C)
1	=	A and B and C
2	=	A and B only
3	=	A and (B or C)
4	=	A only
5	=	A or B (default) only
6	=	A or B or C
7	=	A or B only
8	=	A or C only
9	=	B and C only
10	=	B only
11	=	B or C only
12	=	C only

C.P.C. device

It dialogues with the coin mechanism if devices are installed or removed from the serial interface (C.P.C.-type devices - the monitoring unit is always enabled by default).

Minimum level of tubes

It brings forward the "Insert exact amount" message for the user, by adding a number of coins between 0 and 15 to the programmed number of coins, to set the "full change tubes" status.

Free Vend VMC

Most payment systems with the BDV protocol control the free vend function.

However, there are some payment systems without such function.

In this case, if free selections are to be dispensed, free vending must be enabled with VMC (vending machine control, enabled by default) and the price of the selections must be set to zero.

COMMON FUNCTIONS

IMMEDIATE CHANGE

Normally, the amount of a selection is cashed after the machine sends the message "Selection successful". When this function is enabled, disabled by default, the cash message is sent at the beginning of dispensing.

DECIMAL POINT

Press the confirm button "➡" to display the position of the decimal point, i.e.:

0	decimal point disabled
1	XXX.X
2	XX.XX
3	X.XXX

Press the confirm button "➡", these values will start blinking and can then be modified as necessary.

MASTER/SLAVE

The machine control system is pre-arranged for the connection in a bank of vending machines using special kits. This permits the use of a single payment system for more machines.

In the event of installation in a bank of machines, it can be configured a "Master", i.e. having control over the second machine, or as "Slave", i.e. leaving the control to the other machine.

To be able to use this function there must be a numeric keypad within the bank of machines.

There is the option of installing a numeric keypad in the machine for managing the slave machines without keypad and display.

The master/slave function is not enabled by default.

To enable the function, it is necessary to define which machine is master and which one is slave in the software of the master machine and of the slave machine.

If an Executive payment system in "**Price Holding**" mode is set in the master machine, the information must be set also in the software of the slave machine.

In the event of failed electrical connection, both machines will display the message "Failed communication".

COMBINED SELECTIONS

A combined selection is intended as the association of two selections, one from the master and one from the slave, to the same number (80 to 89) sold at a single price.

Since a numeric keypad is required for setting and controlling the combined selections, the relevant menu is **included only in the software of the snack machine.**

Combined selections can be used either with the Snakky as master and "Brio" as slave (recommended configuration) or vice versa. If one of the two selections is not available, the combined selection is not dispensed. If the immediate change option is not activated on the master machine, it might be possible that the first selection fails. In this case the entire amount is returned. If the second selection fails, it will be possible to decide whether to keep or return the entire amount by activating/deactivating the "**Virtual change return**" option.

RESET SLAVE

This function is used for resetting the programming of a slave to default values.

MONITOR

This function is used for scrolling through all the information of a slave being connected.

When switching on the slave with the display showing this function, the display will indicate in a sequence all information on the slave regarding:

- software version
- type of slave (XX, 0XX, 9XX)
- presence of dispensing detection photocells
- number of trays and compartments
- presence of dispensing compartment lock device
- internal sensor temperature.

To exit the function it will be necessary to switch the master machine off.

SELECTIONS

The selection menu is composed of various sub-menus which allow setting of the different parameters.



WATER DOSE

The water dose (expressed in flow-meter pulses for espresso models and in cc for instant models) can be set for each selection button and therefore each product assigned to such selection; the display indicates the name of the product being selected.

WHIPPER CONTROL

The whipping time can be set for each selection button, for each water dose that composes such selection. The duration can be set in two different modes:

Absolute

i.e. independent from the solenoid valve opening time. The whipping duration is set as tenths of a second for Instant models and as volumetric counter pulses for Espresso models.

Relative

i.e. based on the difference, plus or minus, from the moment the solenoid valve closes. The whipping duration is always expressed in tenths of a second.

SOLENOID VALVE FLOW

It is possible to set the water flow rate of the single solenoid valves expressed in cc/s (the default value setting in cc/s is indicated in the selection dose table) to calculate the amount of water to be dispensed.

SOUND SIGNAL DELAY

To allow the drink to flow completely from the mixer to the cup it is possible, for each selection, to set a delay time after the actual end of dispensing for the signal of "end of dispensing" to the user.

POWDER DOSE

The powder dose, expressed in grams, can be set for each selection button and therefore each product assigned to it; the display indicates the name of the product being selected.

It is also possible to program the doses of a product "Globally", i.e. setting all selections with a single operation.

DOSER DEVICE FLOW

For correct conversion of product dose values, the flow rate of the single doser units, expressed in g/s, can be set to calculate the amount of powder to be dispensed.

ACCESSORIES

Dispensing of sugar, stirrer and cup can be enabled or disabled for each single selection button.

SELECTION STATUS

Each single selection button can either be enabled or disabled.

BUTTON/SELECTION ASSOCIATION

This function is used to change the order of the selections associated to the push-button panel.

The display will indicate in a sequence the list of available selections and when pressing the target button the association is stored.

SELECTION POSITION

When the display shows this function, it will be possible to read the selection to which the pressed button is assigned.

PRODUCT CODE

This function is used for assigning a 4-digit identification code to each selection for processing the statistics.

VENDING MACHINE PARAMETERS

This group of functions controls all parameters concerning the machine operation.



TEMPERATURE

This function is used for setting the operating temperature, expressed in °C, of the boilers installed in the machine. After selecting the boiler, press the confirm button “**↵**”, the temperature value on the display will start blinking and can be modified as necessary.

TANK

For defining whether the machine water supply is from the mains or from an internal tank.

MIXER HEATING

If the function is enabled and no selections were made in the last 3 minutes, a small amount of hot water is dispensed into the milk or instant coffee mixers before dispensing short instant coffee, instant coffee with milk and espresso coffee with milk.

MIXERS COOLING

If the function is enabled and no cold drink selections were made in the last 5 minutes, a small amount of cold water is dispensed into the cold drink mixers before dispensing.

FAST CYCLES

When this function is enabled, some of the time that is useful for improving the drink quality is eliminated.

for instant selections

- All of the products that compose the drink are dispensed at the same time.
- The “post-whipping” time is eliminated.

for espresso selections

- pre-brewing is not performed;
- The pump, used to increase the boiler pressure after an instant drink selection, is not started.
- The “post-whipping” time is eliminated.

SETTING THE REGENERATION COUNTER

It is possible to display the message “Regenerate the water softener” upon accessing “filler” mode after a programmable number of drinks dispensed.

CUP SENSOR

The machine can be fitted with a “cup sensor” composed of photocell that detects the presence of an object in the dispensing compartment.

When the function is enabled, if an object is detected in the dispensing compartment, a cup is not released and the display indicates the message “Without cup”.

It is also possible to define whether, after two attempts to release a cup without the photocell detecting any objects in the dispensing compartment; the failure should lock the machine or leave it to operate using a ceramic cup.

DISPENSING COMPARTMENT LAMP TIMING

The machine can be fitted with a lamp for lighting the dispensing compartment. The time starts from the sound signal at the end of dispensing and can be programmed between 0 and 15 seconds. In any case, the lamp is switched off at the start of the next selection.

If the cup sensor is fitted, the lamp stays on for a programmable time (0 to 30 seconds; 2 by default) from picking up the drink.

COLUMN ROTATION DELAY

This function is used to set the delay time in stopping the cup column rotation in order to compensate any inertia due to the cup type.

WASH BUTTON

With this function it is possible to enable the operation of the mixer wash button.

Normally the button is disabled.

AUTOMATIC WASH

It is possible to set the time when performing an automatic wash of the mixers and a rotation of the brewer units installed. When setting the time to 24.00 the function is disabled.

(default).

DECAF CYCLE

When enabling this function, instant coffee powder (if present) is dispensed in two steps to improve the appearance of the drink.

MAXIMUM NUMBER OF COUNTERS

This function is used for setting the maximum number of selections to be reached for the purpose of disabling the machine. The counters can be set for the following selections:

- Espresso
- Instant
- Espresso + Instant

The number of selections made is reset automatically when a new value is set for the counter.

This function is not active if the counter reset password was not previously set.

PRE-GRINDING

This function is used to enable/disable grinding of the coffee dose for the next selection.

This permits the reduction of dispensing time for a coffee selection

. The function is disabled by default.

BREWING TIME

This function (enabled only in fresh tea models) permits opening of the tea dispensing solenoid valve for a length of time, set in tenths of a second, and delivering of a small amount of water onto the product in order to dampen it before the actual brewing cycle.

DISPLAY

This group of functions controls all parameters concerning the display indications.



LANGUAGE

There is a choice of language, selected among the ones included in the EPROM, to be used for the messages on the display.

ENABLING THE PROMOTIONAL MESSAGE

When in this menu, press the confirm button "↵" to display the status of the message (enabled or disabled). The status can then be changed using the "↑" and "↓" buttons.

SETTING THE PROMOTIONAL MESSAGE

The 4-line message can be written using the "↑" and "↓" buttons to scroll through the available characters.

Press the confirm button "↵", the first character will start blinking and can be modified.

The message is stored by pressing button "←".

LCD CONTRAST CONTROL

This function is used for adjusting the display contrast from 5% to 99% (default).

PRE-SELECTIONS

According to the settings defined via software, the "-" and "+" buttons can be used to vary the amount of sugar or, alternatively of coffee or water.



There is also the option of using some selection buttons to have dispensing:

- without cup;
- with extra sugar, i.e. a greater amount of sugar (programmable) on all selections where it is dispensed;
- with sugar, added to unsweetened selections;
- with extra milk, i.e. a greater amount of milk (programmable) on all selections where it is dispensed.

The symbols ■ ■ ■ □ □ will indicate the average dose change.

It is possible to decide the variation of product dose and variation of selections price for the defined pre-selection.

MISCELLANEOUS

This menu contains some of the functions that are used less frequently concerning the machine parameters.



JUG FACILITIES

Some models, supplied with a special button, permit dispensing of a number of selections (programmable between 1 to 9; 5 as default) without cup to fill a jug.

PASSWORD

It is a 5-digit numeric code which is required to access programming.

The default value of this code is set to 00000.

ENABLING THE PASSWORD

This function is used to enable the option of requesting the password to access programming; the password request is disabled by default.

FILLER MENU MASKING

This function is used to determine the filler menu options to be left active or to be disabled.

The reference numbers of the menus do not change even if some are disabled.

ENERGY SAVING

In order to save electric energy when the machine is not in use, this function is used to switch off the boiler heating.

Day		1	2	3	4	5	6	7
band 1	start	00.00	00.00	00.00	00.00	00.00	00.00	00.00
	end	07.00	07.00	07.00	07.00	07.00	23.59	23.59
band 2	start	22.00	22.00	22.00	22.00	22.00	00.00	00.00
	end	23.59	23.59	23.59	23.59	23.59	00.00	00.00

2 switch-off time bands can be programmed on a weekly basis; the week days are identified by a progressive number (1=Monday, 2=Tuesday etc.).

The same time band cannot include days from different weeks.

If time bands are set overlapping, the machine will remain switched on for the shorter period.

For example, in order to set energy saving time bands to run the vending machine from 07.00 to 22.00 during the week and leave it switched off on the weekend, the time bands should be set, using the special menu, as indicated in the table below.

ESPRESSO UNIT

It is possible to define whether the machine is fitted with an espresso unit of the Z2000 type (standby position with chamber open) or with a Z3000 espresso unit (standby position with chamber closed).

STATISTICS

Data on the machine operations is stored in both general counters and relative counters, which can be reset without losing total data.

GENERAL COUNTER

An electronic counter stores the total of all selections made since the last reset.

The counter can be read and reset.

DISPLAYING GENERAL STATISTICS

When pressing the confirm button "↵" the stored data is sequentially displayed, and namely:

- 1 - counter by single selection;
- 2 - counter by time bands;
- 3 - discount counter;
- 4 - failure counter;
- 5 - coin mechanism data.

RESETTING GENERAL STATISTICS

Statistics can be reset either globally (all types of data) or partially for:

- selections
- discounts/overprice
- failures
- coin mechanism data

Press the confirm button "↵", and the message "Confirm?" starts blinking.

Press the confirm button "↵", the message "Working" is displayed for a few seconds and all statistics are reset.

DISPLAYING RELATIVE STATISTICS

When pressing the confirm button "↵" the stored data is sequentially displayed, and namely:

- 1 - counter by single selection;
- 2 - counter by time bands;
- 3 - discount counter;
- 4 - failure counter;
- 5 - coin mechanism data.

RESETTING RELATIVE STATISTICS

Statistics can be reset either globally (all types of data) or partially for:

- selections
- discounts/overprice
- failures
- coin mechanism data

Press the confirm button "↵", and the message "Confirm?" starts blinking.

Press the confirm button "↵", the message "Working" is displayed for a few seconds and all statistics are reset.

MDB protocol Audit

Aud. 1 Money in the tubes
Money present in the change tube that moment

Aud. 2 Money to the tubes
Money sent to the change tubes

Aud. 3 Money to the box
Money sent to the coin box

Aud. 4 Change return
Total money returned

Aud. 5 Excess
Excess money. Extra amounts paid by the customer that were not returned (in the event there was no money available for return)

Aud. 6 Release tubes
Value of coins dispensed with the "Tubes control" function

Aud. 7 Filling tubes
Value of money cashed with the manual filling function

Aud. 8 Cash sales
Value of total sales with cash money (coins + bills)

Aud. 9 Cashed bills
Value of cashed bills

Audi. 10 Charge key
Value of money changed into the key

Audi. 11 Sales with key
Value of money cashed for dispensing with key

Aud. 12 Money dispensed manually
Value of coins dispensed manually with the dispensing buttons on the coin mechanism.

BDV protocol Audit

The information regarding the coin mechanism indicates the actual currency of:

- Aud. 1 Money in the tubes
Money present in the change tube that moment
- Aud. 2 Money to the tubes
Money sent to the change tubes
- Aud. 3 Money to the box
Money sent to the coin box
- Aud. 4 Return of change
Total money returned
- Aud. 5 Dispensed money
Total money dispensed manually
- Aud. 6 Excess
Excess money. Extra amounts paid by the customer that were not returned (in the event there was no money available for return)
- Aud. 7 Total sales
Total value of sales
- Aud. 8 Exact change
Value of sales in the "no change" condition.
- Aud. 9 Mixed dispensing
Total value of dispensing paid differently; for example also other types of payment (C.P.C., token).
- Aud. 10 Manual filling
Money inserted in the coin mechanism through the manual filling function.

SELECTION COUNTER DISPLAY

This function is used to enable/disable the display of the total number of drinks sold since the last statistic reset, during the start-up phase of the machine.

PRINT

Connect an RS-232 serial printer with a Baud rate of 9600, 8 data bit, no parity, 1 stop bit to the serial port located on the push button board, to print all the statistics described in the section "Displaying the statistics". The hardcopy print-out will also contain the machine code, the date and the software version.

Statistics can be printed partially or totally.

To connect the printer, do as follows:

- press the confirm print button "➡", displaying the message "Confirm?";
- connect the printer before confirming;
- press the confirm button "➡" again to start printing.

TEST

DISPENSE

With this function it is possible to obtain, with the door open and without inserting any money, for each selection dispensing of:

- complete selection
- water only
- powder only
- without accessories (cup, sugar and stirrer)
- accessories only

SPECIAL FUNCTIONS

By accessing this function it is possible to:

- activate the brewer unit;
- the brewer unit is rotated, coffee is ground and then released when a full dose is reached.
- open a solenoid valve to allow the intake of air in the event of emptying the boiler for maintenance;
- manually install boiler.

AUTOTEST

This function allows testing of the main machine components.

Press button "➡" and the message "AUTOTEST" will start blinking.

Press button "⬅" to cancel the operation, confirm with button "➡" to start the autotest routine.

In a sequence:

- fan functioning test for 2 seconds
- the mixers are activated for 2 seconds
- the mixers are activated for 2 seconds
- a cup is released
- rotation of the brewer unit
- wash button check
- waste container switch; the machine awaits until the waste container micro-switch is manually operated
- switching on of the dispensing compartment lamp
- push-button panel test; the machine will display the number of the button which must be pressed and awaits the actuation before going to the next button
- buzzer functioning test
- coin mechanism functioning test

MISCELLANEOUS

This menu contains some sub-menus, used less frequently, which permit control of the functions described below.

MACHINE INFORMATION

INSTALLATION DATE

This function is used to store the current date of system as installation date.

The date is printed when retrieving the statistics.

PROGRAMMING THE MACHINE CODE

When the "Machine code" function is displayed the eight-digit numeric code identifying the machine can be changed (from the default 0).

PROGRAMMING THE OPERATOR CODE

When the "Operator code" function is displayed the six-digit numeric code identifying groups of machines can be changed (from the default 0).

INITIALISING

When the "Initialise" function is displayed the vending machine can be initialised restoring all default data.

This function should be used if there is a memory data error or when the software is replaced.

All statistic information will be reset.

Press confirm button "↵" and the display will indicate the message "Confirm?". Press the confirm button "↵" again and some parameters will be requested, which are:

"Model"

Defining whether the machine is Espresso or Instant

"Country"

intended as type of base doses for the different selections (e.g. IT coffee = 45 cc - FR coffee = 80 cc).

The "country" setting is:

- USA

"Layout"

A number of Button/Selection combinations to choose from is provided for each dose type model (the combinations available for each layout are indicated in the dose selection table supplied with the machine).

"Tank"

Defining whether the water supply is:

0 - from the mains

1 - from an internal tank

2 - from two internal tanks

When confirming the options the message "Working" is displayed for a few seconds.

EVADTS CODES

The EVADTS (European Vending Association Data Transfer System) communication protocol has two codes for identifying the machine and for recognising the data transfer terminal:

PASS CODE

It is a four-digit alphanumeric code (0-9; A-F) that must be the same as the one in the data transfer terminal to allow its identification.

Press the confirm button "↵" and the code is displayed as "0000" regardless of the actual value; then press the correction button "←" and the first digit will start blinking.



Using the scrolling buttons, its value can be changed (during the change operation the value becomes visible). Press the change button "↵" and the next digit starts blinking.

Press the confirm key "↵" after changing the fourth digit; the value is stored and the display indicates "0000" again.

SECURITY CODE

It is a further alphanumeric code for reciprocal recognition between machine and EVADTS terminal.

Programming works as in the "Pass" code.

Connection

This function places the machine in wait mode for connection to retrieve data.

EVADTS CONNECTION

When activating this function, the machine awaits the connection with a device to acquire the EVADTS statistics.

UP-KEY SETUP CONTROL

Up-Key -> vending machine

When confirming this function after inserting the Up-Key in the special port located on the C.P.U. board, it will be possible to select the setup file from the list shown on the display using the scrolling buttons, then when confirming with the confirm button the selected setup will be loaded in the vending machine.

Vending machine -> Up-Key

When confirming this function after inserting the Up-Key in the special port located on the C.P.U. board, it will be possible to save the setup file to the Up-Key with the configuration present in that moment in the vending machine, indicating the name to be assigned to the file (e.g.: Brio000.STP).

Delete

This function is used for deleting one by one the setup files present in the inserted Up-Key.

Delete all

This function is used for deleting all the setup files present in the inserted Up-Key.

UP-KEY STATISTICS CONTROL

Vending machine -> Up-Key

When confirming this function after inserting the Up-Key in the special port located on the C.P.U. board, it will be possible to save the statistics file to the Up-Key with all of the statistics files present in that moment in the vending machine, indicating the name to be assigned to the file (e.g.: Brio000.STA).

Delete

This function is used for deleting one by one the statistics files present in the inserted Up-Key.

Delete all

This function is used for deleting all the statistics files present in the inserted Up-Key.

GSM

The control software can send, via GSM modem, a signal indicating a machine failure or an "ending product" "pre-alarm", after dispensing a certain (programmable) number or quantity of a given product.



The machine fitted with the modem can have the function of "master GSM", i.e. collect and transmit data from other banked machines.

PIN CODE

This function is used for programming the identification code of the SIM card (0000 by default) that will be sent to the GSM modem (optional) when switching the machine on.

SETTING THE THRESHOLDS

This function is used for defining the number of pieces or grams of powder for a given product, after which a "running-out" "pre-alarm" is signalled via modem.

RESETTING THE COUNTERS

With this function the counters that control the pre-alarms are reset.

When pressing the confirm button "→" the values are reset.

BANK NUMBER

The number in the bank of machines (1 to 7) that identifies the machines that have the "slave GSM" function, therefore sending data via the modem to the "master" machine.

The number 0 identifies the machine that is connected directly to the modem, i.e. the "master GSM".

Chapter 3 MAINTENANCE

The integrity of the machine and compliance with the standards of the relevant systems must be checked at least once a year by qualified personnel.

Before starting any maintenance operations requiring parts of the unit to be removed, the machine must always be switched off.

The operations described below must be carried out only by personnel who have the specific knowledge of the machine functioning from a point of view of electrical safety and health regulations.

INTRODUCTION

To ensure correct operation for a long period, the machine must be subjected to regular maintenance.

The following sections contain the procedures and the maintenance schedule, which are only a general indication, as they greatly depend on the operating conditions (e.g. water hardness, environmental humidity and temperature, type of product used, etc.).

The procedures described in this chapter are not exhaustive of all maintenance operations to be carried out.

More complex operations (e.g. boiler descaling) should be carried out by qualified technicians only having specific knowledge of the machine.

To prevent oxidation or the action of chemical agents, the stainless steel and varnished surfaces should be kept clean by using mild detergents (solvents must not be used).

Under no circumstances should water jets be used to clean the machine.

ESPRESSO UNIT MAINTENANCE

Every 10,000 selections or every 6 months some maintenance of the coffee unit must be carried out.

Maintenance is carried out as follows:

- remove the boiler Teflon hose connection from the upper piston, paying attention not to lose the seal (see Fig. 24);
- undo the knob securing the unit to the bracket;
- remove the coffee unit.

Removing the upper filter

- Take the snap ring out of its seat;
- remove the piston from the crosspiece;
- remove the filter and the piston seal.

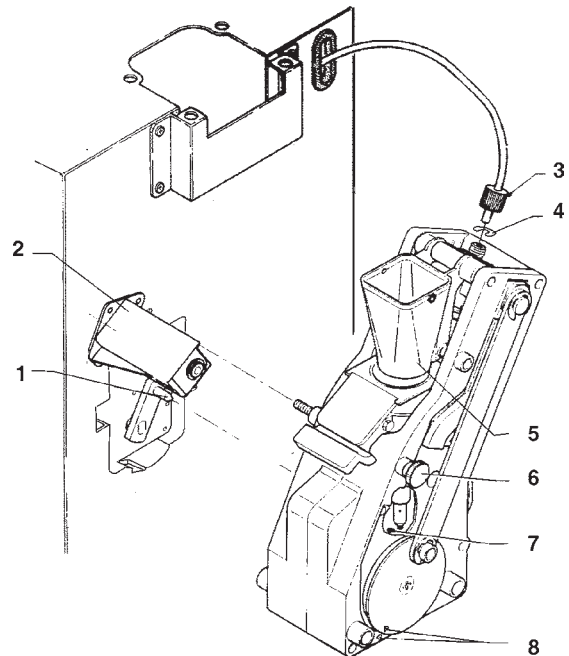

Fig. 24

- 1 - Ratiomotor handle pin
- 2 - Brewing chamber heater (optional)
- 3 - Boiler connecting hose
- 4 - Upper piston snap ring
- 5 - Coffee funnel
- 6 - Unit securing knob
- 7 - Lower piston snap ring
- 8 - Reference notches

Removing the lower filter

- Loosen screws A and B enough to release the coffee funnel (see fig. 24);
- remove the lower piston snap ring;
- take the piston out of brew chamber and remove the filter. Soak all components removed from the unit in a solution of boiling hot water and coffee machine detergent for approx. 20 minutes. Thoroughly rinse and dry all parts, then reinstall them in the reverse order of disassembly, taking particular care that:
 - the piston is positioned in the correct notch for the coffee dose used (see relevant section);
 - the two reference notches match and that the coffee unit is inserted.

Important notice!!!

Check that the handle pin of the ratiomotor is correctly engaged in its seat.

CLEANING THE CUP DISPENSER

The cup dispenser was designed to be disassembled easily for maintenance operations.

Each single column of the cup stacker and the release ring can be disassembled without using tools.

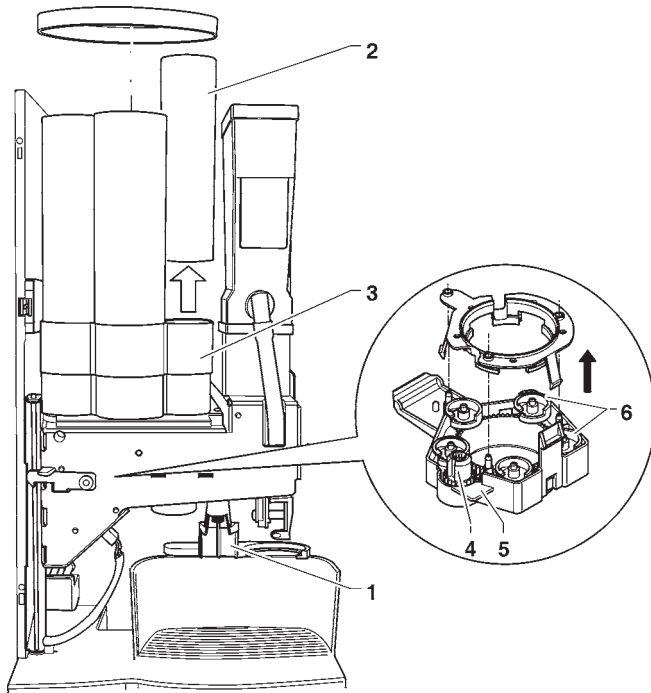
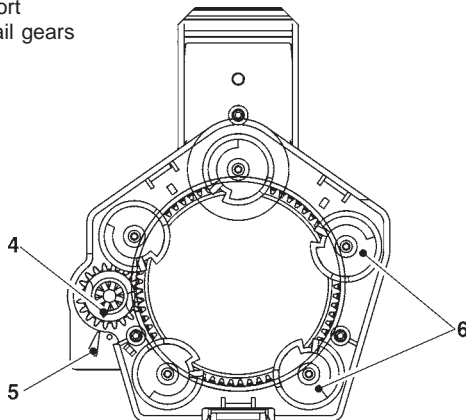

Fig. 25

- 1 - Cup shift arm
- 2 - Removable column
- 3 - Cup stacker
- 4 - Micro-switch actuation gear
- 5 - Snail gear support
- 6 - Cup release snail gears



The cup release ring must not be opened for normal cleaning.

Should any adjustments be necessary during re-assembly, special attention must be paid to:

- line up the notch on the micro-switch actuation gear with the arrow on the snail gear support.
- respect the orientation of the snail gears, as indicated in the figure.

PERIODICAL CLEANING

At least once a year, or more frequently according to the use of the machine and the quality of the inlet water, the entire foodstuff circuit system must be cleaned and sanitized as described below.

SANITISING

- all parts of the hydraulic system in contact with food, including the hoses, must be removed from the unit and fully disassembled;
- all visible residue and product films are mechanically removed using brushes or similar tools, if necessary;
- all components must be soaked in a sanitising solution for at least 20 minutes;
- the unit internal surfaces are to be cleaned with the same sanitising solution;
- thoroughly rinse and then reinstall the parts.

Before restarting the machine, the same sanitising procedure described in section "Sanitising the mixers and the foodstuff circuits" should be repeated.

CLEANING THE PRODUCT CONTAINERS

- Remove the containers from the machine;
- undo the product ports and slide out the augers from back of the container;
- clean all parts in a solution of hot water and sanitising products and dry thoroughly.

PRINTED BOARD FUNCTIONS AND INDICATOR LAMPS

ACTUATION BOARD

This board (see Fig. 26) activates the 120 V~ power users by means of relays. Furthermore, it controls the signals from the cams and/or the micro-switches on the various power users as well as the boiler.

This board is powered with 24 VAC.

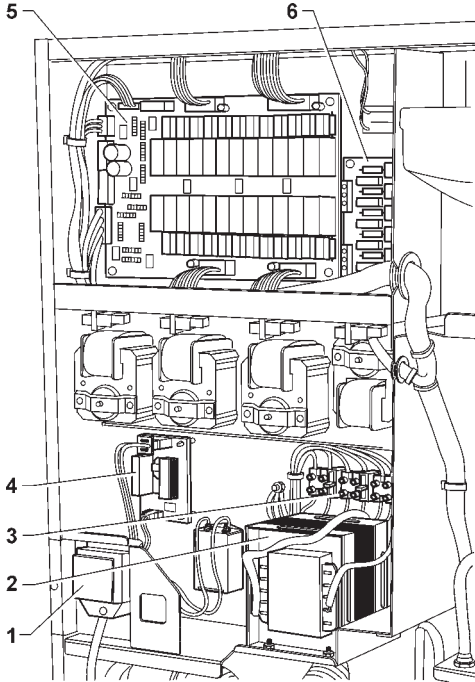

Fig. 26

- 1 - Line cable connection clamp
- 2 - Electronic card and coin mechanism power supply transformer
- 3 - Transformer fuses
- 4 - Boiler heating Triac board
- 5 - Actuation board
- 6 - Expansion board

RELAY FUNCTION (see Wiring diagram)

Espresso

- K1 = ESC
- K2 = MSB
- K3 = MSCB
- K4 = MSP
- K5 = VENT
- K6 = LF
- K7 = EVH2O
- K8 = M
- K9 = MF3
- K10 = MF2
- K11 = MF1
- K12 = MDZ
- K13 = PM
- K14 = ER
- K15 = E1
- K16 = E2
- K17 = E3
- K18 = EEA
- K19 = Not used
- K20 = MAC
- K21 = MD4
- K22 = MD3
- K23 = MD2
- K24 = MD1

The control software of the board is installed directly (via RS232 or with UpKey on the CPU) in the microprocessor.

- the green LED (2) blinks during normal operation of the board
- the yellow LED (6) indicates the presence of 5 V DC
- the red LED (3) glows during the board reset
- the red LED (10) indicates the operating status of the boiler heating element

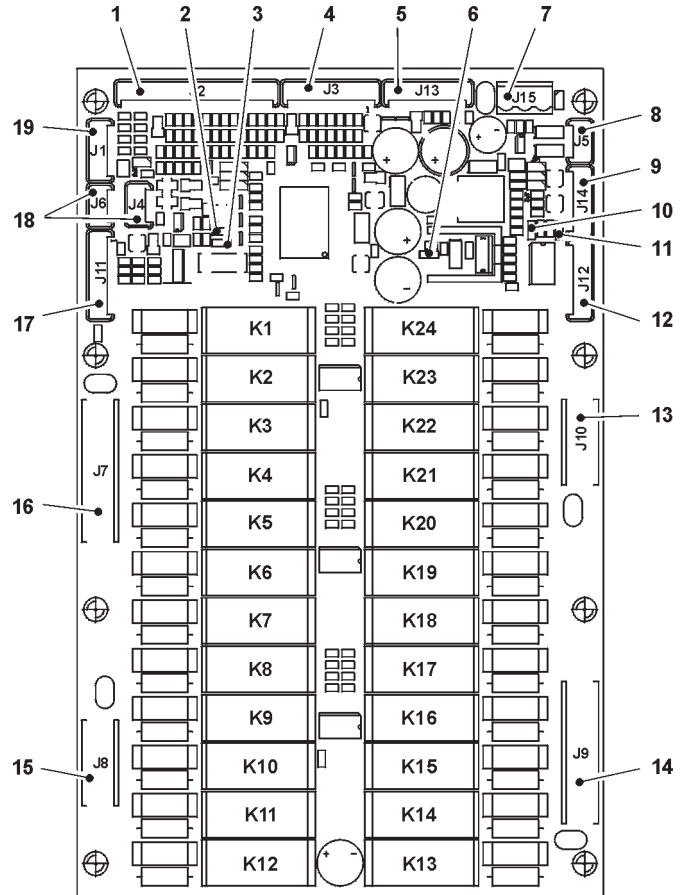

Fig. 27

- 1 - Input signal
- 2 - Green LED
- 3 - Red LED
- 4 - Not used
- 5 - Connector for board programming (RS232)
- 6 - Yellow LED
- 7 - Board power supply (24 VAC)
- 8 - Not used
- 9 - Boiler probe and control
- 10 - Red LED - boiler heating element
- 11 - Red LED (not used)
- 12 - Expansion board connection
- 13 - 120 V~ power users
- 14 - 120 V~ power users
- 15 - 120 V~ power users
- 16 - 120 V~ power users
- 17 - Not used
- 18 - "Can Bus" connection
- 19 - Not used

PUSH-BUTTON BOARD

This board controls the alphanumeric display, the selection buttons and, located on the internal side, the printer serial port and the service buttons.

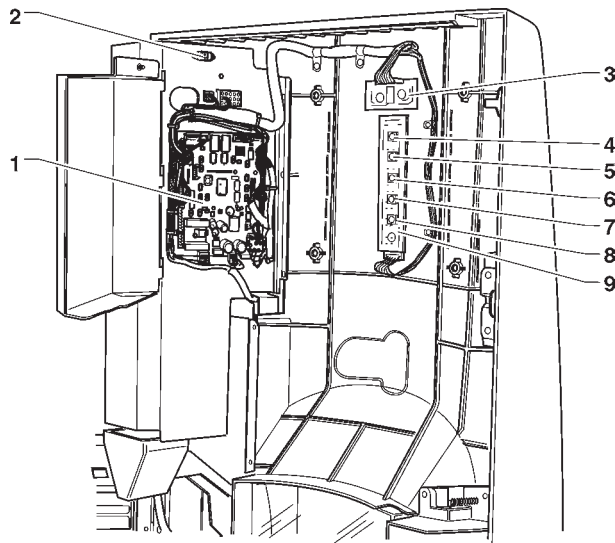

Fig. 28

- 1 - CPU board
- 2 - RS232 serial port
- 3 - Display card
- 4 - Cup release button
- 5 - Statistic reading button
- 6 - Failure reset button
- 7 - Mixer cleaning button
- 8 - Programming access button
- 9 - Push-button board

C.P.U. BOARD

The C.P.U. (Central Processing Unit) board controls all power users set for the maximum configuration, processes the input signals from the keypad and from the payment system. It also controls the actuation and display cards. The Leeds furnish the following indications during the vending machine operation:

- Green LED (3): blinks during normal operation of the C.P.U. board;
- Yellow LED (4): glows when 5 VDC are detected;
- Red LED (7): glows when, for any reason, the software is reset.

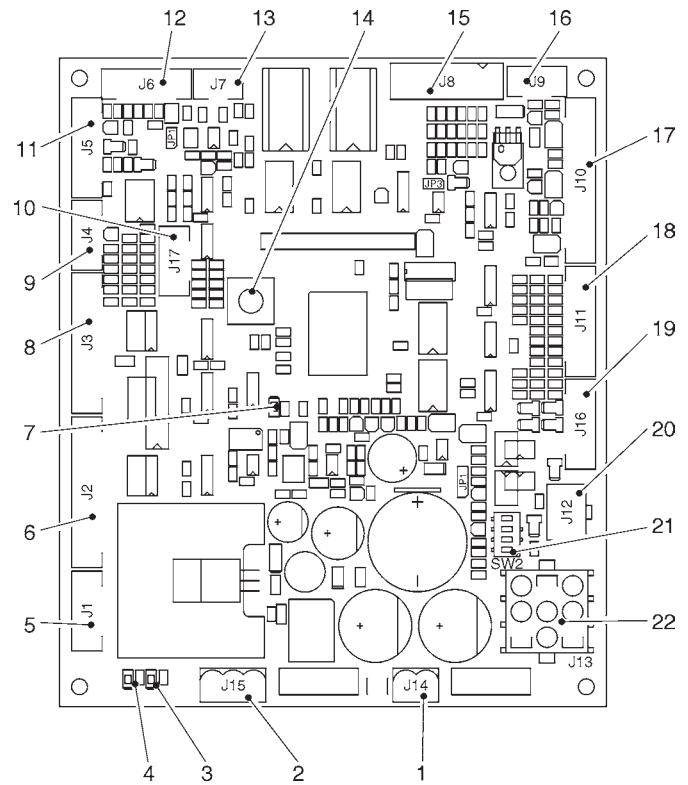

Fig. 29

- 1 - J14 MDB and BDV coin mechanism power supply
- 2 - J15 Board power supply
- 3 - Green LED: run (DL2)
- 4 - Yellow LED: 5 V DC (DL1)
- 5 - Not used
- 6 - Not used
- 7 - Red LED: CPU reset (DL3)
- 8 - J3 Input/output
- 9 - J4 Not used
- 10 - J17 Up Key connector
- 11 - J5 RS232 cables
- 12 - J6 Not used
- 13 - J7 Can-Bus
- 14 - Button not used
- 15 - J8 Validators
- 16 - J9 Not used
- 17 - J10 LCD display
- 18 - J11 Keypad
- 19 - J9 Numeric push-button panel input (optional)
- 20 - J12 MDB coin mechanism
- 21 - Coin mechanism setting dip-switches (SW2)
- 22 - J13 Expansion for BDV / EXE

CONFIGURING THE ELECTRONIC BOARDS

The electronic boards are designed to be used in many machine models.

In the event of replacement, or when wishing to change the machine performance, it will be necessary to check the configuration of the boards and install the appropriate software.

SOFTWARE UPDATE

The machine is fitted with Flash EPROMs which can be electronically updated.

By means of a special program and suitable system (Personal Computer, Up Keys or similar) the machine management software can be updated without replacing the EPROMs.

HYDRAULIC SYSTEM FOR ESPRESSO

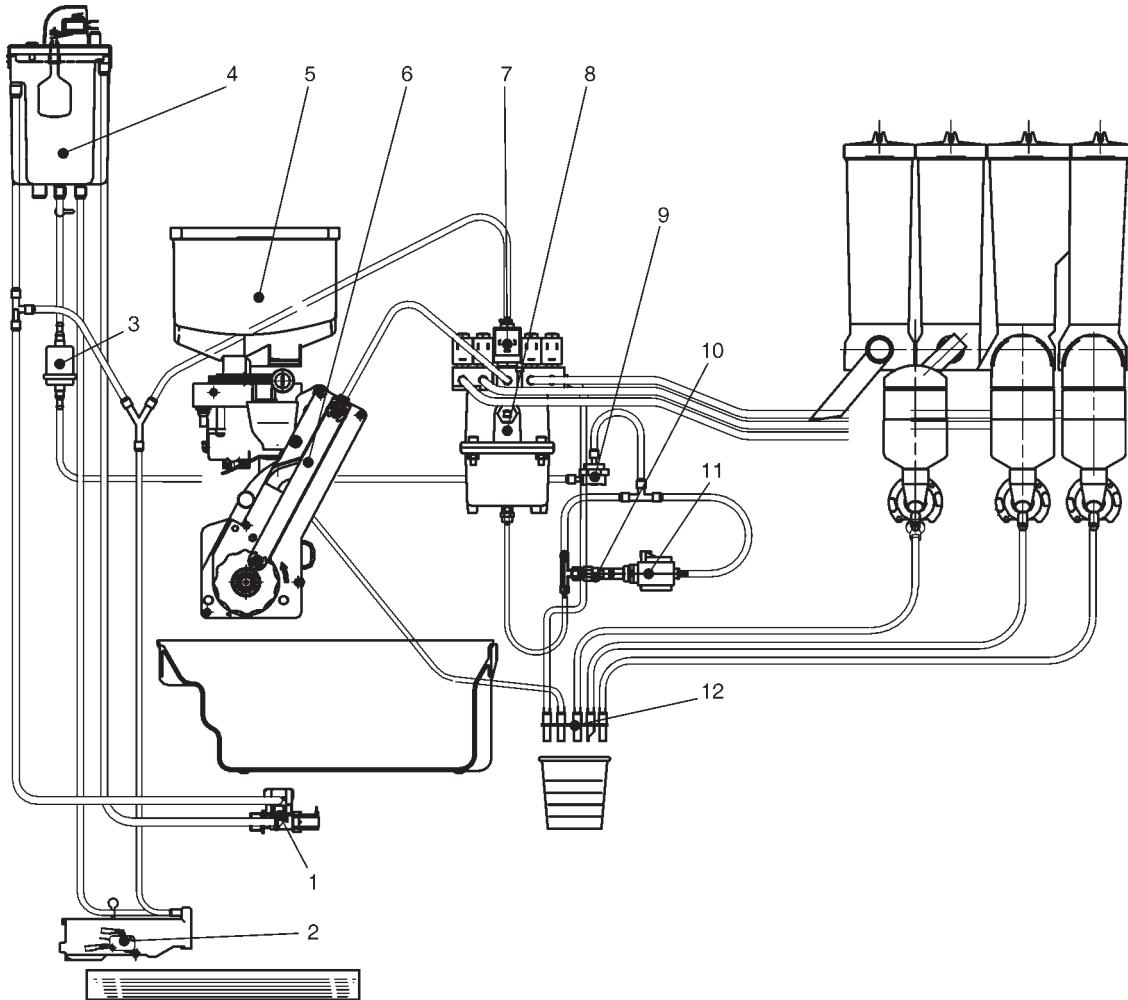

- 1 - Water inlet solenoid valve
- 2 - Liquid waste container float
- 3 - Mechanical filter
- 4 - Air-break
- 5 - Coffee beans hopper
- 6 - Brewer unit

- 7 - Solenoid valve assembly
- 8 - Boiler
- 9 - Volumetric counter
- 10- Bypass
- 11 - Vibration pump
- 12 - Dispensing spouts assembly

HYDRAULIC SYSTEM

Equipped base cabinet

Water supply tank and water softener (optional)

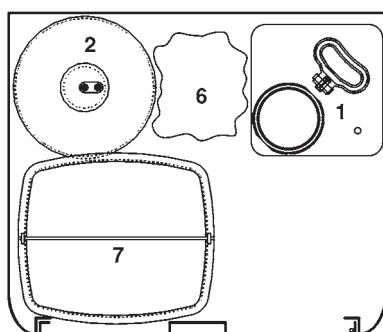
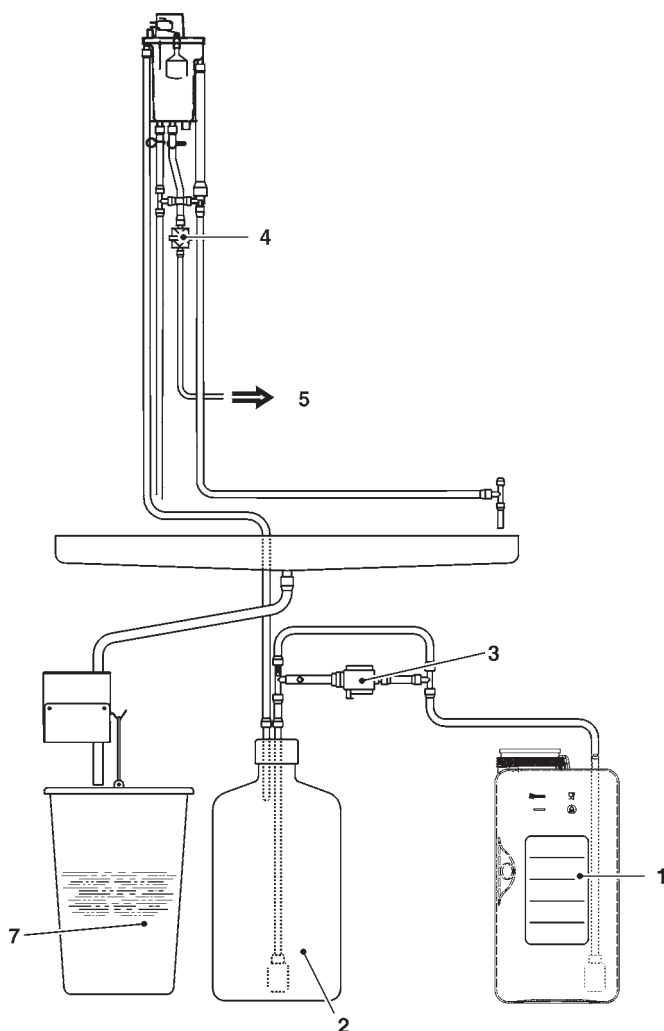

- 1 - Water tank
- 2 - Water softener (optional)
- 3 - Water supply pump
- 4 - Mechanical filter

- 5 - To the machine
- 6 - Coffee grounds bag
- 7 - Liquid waste container

Programming Menu Summary

The machine can function in 3 different operating modes:

- Normal vending mode
- Filler menu
- Technician menu

In order to access the programming menus, press the programming button located on the push-button card:

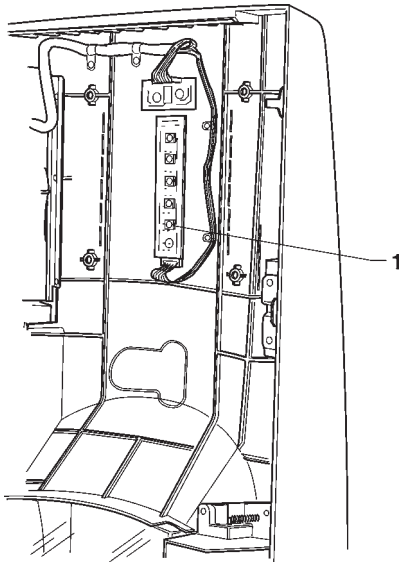

Fig. 30

1 - Programming access button

At this point the machine goes into Filler menu mode. The buttons shown in the figure are used for surfing through the different menus:

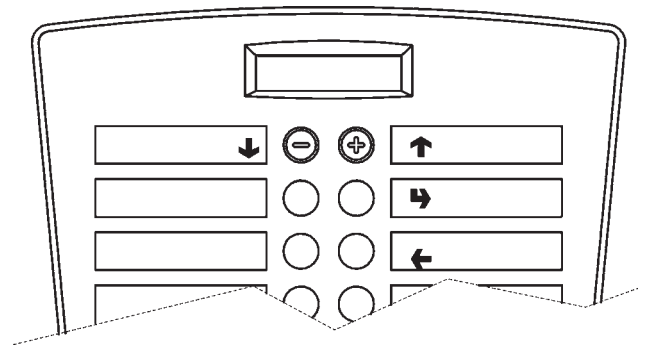

Fig. 31

Scrolling buttons UP (↑) and DOWN (↓)

The UP and DOWN scrolling buttons are used for moving from one programming menu item to the next one, located in the same level, and at the same time change the status or the numeric value of the corresponding functions.

Confirm / enter button (↵)

The confirm / enter button is used for moving to the lower level or for confirming a value after being entered or changed.

Exit button (←)

The exit button is used for returning to the higher level or for exiting a change field of a function. When reaching the highest level in the menu, this button is pressed for going from the Technician menu into the Filler menu and vice versa.

"Filler Menu" Summary

1 - STATISTICS

1.1 - PRINT STATISTICS

- 1.1.1 - PARTIAL PRINTOUT
 - 1.1.1.1 - PRINT SEL. COUNT
 - 1.1.1.2 - PRINT BAND COUNT
 - 1.1.1.3 - PRINT DISC COUNT
 - 1.1.1.4 - PRINT FAIL COUNT
 - 1.1.1.5 - PRNT C MECH DATA

1.1.2 - TOTAL PRINTOUT

1.2 - PRINT REL. STATS

- 1.2.1 - PARTIAL PRINTOUT
 - 1.2.1.1 - PRINT SEL. COUNT
 - 1.2.1.2 - PRINT BAND COUNT
 - 1.2.1.3 - PRINT DISC COUNT
 - 1.2.1.4 - PRINT FAIL COUNT

1.2.1.5 - PRNT C MECH DATA

1.2.2 - TOTAL PRINTOUT

1.3 - DISPLAY STATS

- 1.3.1 - DIS. SEL. COUNT.
 - 1.3.1.1 - DIS. SIN. COUNT.
 - 1.3.1.2 - DIS. TOT. COUNT.
 - 1.3.1.3 - DIS. SEL. COUNT.
- 1.3.2 - DIS. BAND COUNT.
- 1.3.3 - DIS. DISC. SEL.
- 1.3.4 - DIS. FAIL.COUNT.
- 1.3.5 - DIS. C MECH DATA
 - 1.3.5.1 - DIS. AUDIT DATA
 - 1.3.5.2 - DIS. CASH COUNT.

1.4 - DIS. REL. STATS

- 1.4.1 - DIS. SEL. COUNT.
 - 1.4.1.1 - DIS. SIN. COUNT.
 - 1.4.1.2 - DIS. TOT. COUNT.
 - 1.4.1.3 - DIS. SEL. COUNT.
- 1.4.2 - DIS. BAND COUNT.
- 1.4.3 - DIS. DISC. SEL.
- 1.4.4 - DIS. FAIL.COUNT.
- 1.4.5 - DIS. C MECH DATA
 - 1.4.5.1 - DIS. AUDIT DATA
 - 1.4.5.2 - DIS. CASH COUNT.

1.5 - DEL. REL. STATS

- 1.5.1 - DELETE PARTIAL
 - 1.5.1.1 - DELETE SE. COUNT
 - 1.5.1.2 - DEL. DISC. COUNT
 - 1.5.1.3 - DEL. FAIL. COUNT
 - 1.5.1.4 - DEL. C MECH DATA
- 1.5.2 - DELETE TOTAL

2 - SET SIN. PRICES

- 2.1 - PRICE BAND 0
- 2.2 - PRICE BAND 1
- 2.3 - PRICE BAND 2
- 2.4 - PRICE BAND 3
- 2.5 - PRICE BAND 4

3 - TUBES CONTROL

3.1 - FILL TUBES

3.2 - RELEASE TUBES

↓ NEXT FUNCTION/
INCREASE DATA UNIT (+1)

➡ CONFIRM DATA /
CONFIRM FUNCTION

↑ PREVIOUS FUNCTION /
DECREASE DATA UNIT (-1)

← DELETE DATA /
EXIT FUNCTION

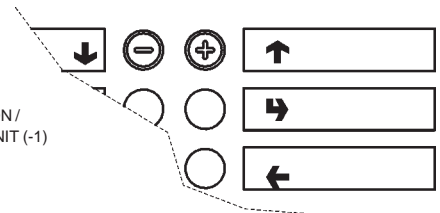

"Filler Menu" Summary

4 - BOILER TEMPERAT.

5 - TEST

5.1 - COMP. DISPENSING

5.2 - WATER ONLY

5.3 - POWDER ONLY

5.4 - NO ACCESSORIES

5.5 - ACCESSORIES ONLY

↓ NEXT FUNCTION/
INCREASE DATA UNIT (+1)

➡ CONFIRM DATA /
CONFIRM FUNCTION

↑ PREVIOUS FUNCTION /
DECREASE DATA UNIT (-1)

← DELETE DATA /
EXIT FUNCTION

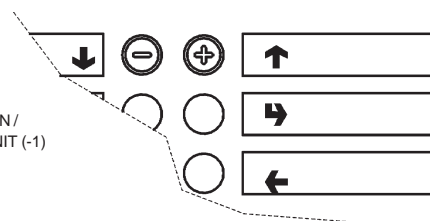

"Technician Menu" Summary

1 - FAILURES

1.1 - READING FAILURES

1.2 - RESET FAILURES

2 - SET PARAMETERS

2.1 - CASH

2.1.1 - PRICES

2.1.1.1 - SET SIN. PRICES

2.1.1.1.1 - PRICE BAND 0

2.1.1.1.2 - PRICE BAND 1

2.1.1.1.3 - PRICE BAND 2

2.1.1.1.4 - PRICE BAND 3

2.1.1.1.5 - PRICE BAND 4

2.1.1.2 - SET GLOB. PRICES

2.1.1.2.1 - PRICE BAND 0

2.1.1.2.2 - PRICE BAND 1

2.1.1.2.3 - PRICE BAND 2

2.1.1.2.4 - PRICE BAND 3

2.1.1.2.5 - PRICE BAND 4

2.1.1.3 - TIME BANDS

2.1.1.3.1 - SET DATE & TIME

2.1.1.3.2 - TIME BAND 1

2.1.1.3.3 - TIME BAND 2

2.1.1.3.4 - TIME BAND 3

2.1.1.3.5 - TIME BAND 4

2.1.2 - COIN MECHANISMS

2.1.2.1 - COIN MECH SETT.

2.1.2.2 - IMMEDIATE CHANGE

2.1.3 - DECIMAL POINT

2.1.4 - MASTER SLAVE

2.1.4.1 - SET UP

2.1.4.2 - SLAVE PRICE HOLD

2.1.4.3 - VIRT. PRICE RET.

2.1.4.4 - RESET SNAKKY SL

2.1.4.5 - MONITOR SLAVE

2.2 - SELECTIONS

2.2.1 - SET WATER

2.2.1.1 - WATER DOSES

2.2.1.2 - SET WHIP DOSES

2.2.1.2.1 - SET DOSES

2.2.1.2.2 - SET MODALITY

2.2.1.3 - SOLENOID SETTING

2.2.1.4 - INFUSION TIME

2.2.2 - SET POWDER

2.2.2.1 - POWDER DOSES

2.2.2.2 - DOSER SETTINGS

2.2.3 - SET ACCESSORIES

2.2.3.1 - ENABLE CUP

2.2.3.2 - ENABLE SUGAR

2.2.3.3 - ENABLE STIRRER

2.2.4 - SELECTION STATUS

2.2.5 - SELECTION BUTTON

2.2.6 - CONNECTION

2.2.7 - PRODUCT CODE

2.3 - MACHINE PARAM.

2.3.1 - BOILER TEMPERAT.

2.3.2 - TANK

2.3.3 - MIXER HEATING

2.3.4 - MIXER COOLING

2.3.5 - FAST CYCLES

2.3.6 - SET DISP. MAINT.

2.3.7 - PHOTOCELL

2.3.8 - NEON TIME

2.3.9 - SET CUP SETTling

2.3.A - EN. WASH BUTTON

2.3.B - EN. AUTOM. WASH

2.3.C - DEC. CYCLE

2.3.D - NUM.MAX.CONT

2.3.E - PREGRINDING

2.3.F - INFUSION TIME

↓ NEXT FUNCTION/
INCREASE DATA UNIT (+1)

➡ CONFIRM DATA /
CONFIRM FUNCTION

↑ PREVIOUS FUNCTION /
DECREASE DATA UNIT (-1)

← DELETE DATA /
EXIT FUNCTION

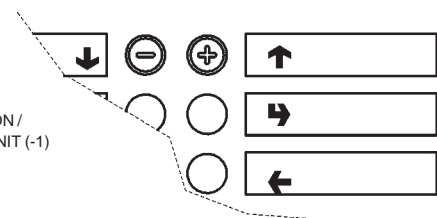

"Technician Menu" Summary



2.4 - DISPLAY



- 2.4.1 - LANGUAGE
- 2.4.2 - PROMOT. MESSAGE
 - 2.4.2.1 - EN. PROM. MESS.
 - 2.4.2.2 - SET PROM. MESS.
- 2.4.3 - CONTRAST CONTROL

2.5 - PRE-SELECTIONS

- 2.5.1 - NO CUP
 - 2.5.1.1 - SELECTION ENABL.
 - 2.5.1.2 - DOSE VARIATION
 - 2.5.1.3 - PRICE VARIATION
- 2.5.2 - EXTRA SUGAR
 - 2.5.2.1 - SELECTION ENABL.
 - 2.5.2.2 - DOSE VARIATION
 - 2.5.2.3 - PRICE VARIATION
- 2.5.3 - SUGAR
 - 2.5.3.1 - SELECTION ENABL.
 - 2.5.3.2 - DOSE VARIATION
 - 2.5.3.3 - PRICE VARIATION
- 2.5.4 - SUGAR -
 - 2.5.4.1 - SELECTION ENABL.
 - 2.5.4.2 - DOSE VARIATION
 - 2.5.4.3 - PRICE VARIATION
- 2.5.5 - SUGAR +
 - 2.5.5.1 - SELECTION ENABL.
 - 2.5.5.2 - DOSE VARIATION
 - 2.5.5.3 - PRICE VARIATION
- 2.5.6 - WATER +
 - 2.5.6.1 - SELECTION ENABL.
 - 2.5.6.2 - DOSE VARIATION
 - 2.5.6.3 - PRICE VARIATION
- 2.5.7 - WATER -
 - 2.5.7.1 - SELECTION ENABL.
 - 2.5.7.2 - DOSE VARIATION
 - 2.5.7.3 - PRICE VARIATION

- 2.5.8 - STRENGHT +
 - 2.5.8.1 - SELECTION ENABL.
 - 2.5.8.2 - DOSE VARIATION
 - 2.5.8.3 - PRICE VARIATION
- 2.5.9 - STRENGHT -
 - 2.5.9.1 - SELECTION ENABL.
 - 2.5.9.2 - DOSE VARIATION
 - 2.5.9.3 - PRICE VARIATION
- 2.5.A - COFFEE PWD. DOSE
 - 2.5.A.1 - SELECTION ENABL.
 - 2.5.A.2 - DOSE VARIATION
 - 2.5.A.3 - PRICE VARIATION
- 2.5.B - EXTRA MILK
 - 2.5.B.1 - SELECTION ENABL.
 - 2.5.B.2 - DOSE VARIATION
 - 2.5.B.3 - PRICE VARIATION
- 2.5.C - MOKKA
 - 2.5.C.1 - SELECTION ENABL.
 - 2.5.C.2 - DOSE VARIATION
 - 2.5.C.3 - PRICE VARIATION
- 2.5.D - JUG +
 - 2.5.D.1 - SELECTION ENABL.
 - 2.5.D.2 - DOSE VARIATION
 - 2.5.D.3 - PRICE VARIATION
- 2.5.E - JUG -
 - 2.5.E.1 - SELECTION ENABL.
 - 2.5.E.2 - DOSE VARIATION
 - 2.5.E.3 - PRICE VARIATION

 NEXT FUNCTION/
INCREASE DATA UNIT (+1)
 CONFIRM DATA /
CONFIRM FUNCTION

 PREVIOUS FUNCTION /
DECREASE DATA UNIT (-1)
 DELETE DATA /
EXIT FUNCTION

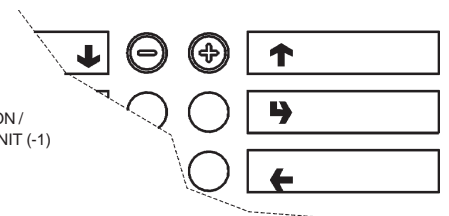

"Technician Menu" Summary

2.6 - MISCELLANEOUS

- 2.6.1 - JUG FACILITIES
- 2.6.2 - PASSWORD
 - 2.6.2.1 - SET PASSWORD
 - 2.6.2.2 - ENABLE PASSWORD
- 2.6.3 - ENABLE FILL MENU
- 2.6.4 - EN. AUTOM. WASH
 - 2.6.4.1 - ENERGY SAVING
 - 2.6.4.2 - SET ENER. SAVING

3 - STATISTICS

3.1 - ELECTRIC COUNTER

- 3.1.1 - DIS. COUNTERS
- 3.1.2 - RESET COUNTER

3.2 - DISPLAY STATS

- 3.2.1 - DIS. SEL. COUNT.
 - 3.2.1.1 - DIS. SIN. COUNT.
 - 3.2.1.2 - DIS. TOT. COUNT.
 - 3.2.1.3 - DIS. SEL. COUNT.
- 3.2.2 - DIS. BAND COUNT.
- 3.2.3 - DIS. DISC. SEL.
- 3.2.4 - DIS. FAIL.COUNT.
- 3.2.5 - DIS. C MECH DATA
 - 3.2.5.1 - DIS. AUDIT DATA
 - 3.2.5.2 - DIS. CASH COUNT.

3.3 - DEL. STATISTICS

- 3.3.1 - DELETE PARTIAL
 - 3.3.1.1 - DELETE SE. COUNT
 - 3.3.1.2 - DEL. DISC. COUNT
 - 3.3.1.3 - DEL. FAIL. COUNT
 - 3.3.1.4 - DEL. C MECH DATA
- 3.3.2 - DELETE TOTAL

3.4 - DIS. REL. STATS

- 3.4.1 - DIS. SEL. COUNT.
 - 3.4.1.1 - DIS. SIN. COUNT.
 - 3.4.1.2 - DIS. TOT. COUNT.
 - 3.4.1.3 - DIS. SEL. COUNT.
- 3.4.2 - DIS. BAND COUNT.
- 3.4.3 - DIS. DISC. SEL.
- 3.4.4 - DIS. FAIL.COUNT.
- 3.4.5 - DIS. C MECH DATA
 - 3.4.5.1 - DIS. AUDIT DATA
 - 3.4.5.2 - DIS. CASH COUNT.

3.5 - DEL. REL. STATS

- 3.5.1 - DELETE PARTIAL
 - 3.5.1.1 - DELETE SE. COUNT
 - 3.5.1.2 - DEL. DISC. COUNT
 - 3.5.1.3 - DEL. FAIL. COUNT
 - 3.5.1.4 - DEL. C MECH DATA
- 3.5.2 - DELETE TOTAL

3.6 - EN. CNT AT START

3.7 - PRINT STATISTICS

- 3.7.1 - PARTIAL PRINTOUT
 - 3.7.1.1 - PRINT SEL. COUNT
 - 3.7.1.2 - PRINT BAND COUNT
 - 3.7.1.3 - PRINT DISC COUNT
 - 3.7.1.4 - PRINT FAIL COUNT
 - 3.7.1.5 - PRNT C MECH DATA
- 3.7.2 - TOTAL PRINTOUT

↓ NEXT FUNCTION/
INCREASE DATA UNIT (+1)

➡ CONFIRM DATA /
CONFIRM FUNCTION

↑ PREVIOUS FUNCTION /
DECREASE DATA UNIT (-1)

← DELETE DATA /
EXIT FUNCTION

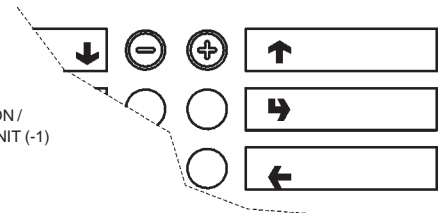

"Technician Menu" Summary

3.8 - PRINT REL. STATS

3.8.1 - PARTIAL PRINTOUT

- 3.8.1.1 - PRINT SEL. COUNT
- 3.8.1.2 - PRINT BAND COUNT
- 3.8.1.3 - PRINT DISC COUNT
- 3.8.1.4 - PRINT FAIL COUNT
- 3.8.1.5 - PRNT C MECH DATA

3.8.2 - TOTAL PRINTOUT

4 - TEST

4.1 - TEST DISPENSING

- 4.1.1 - COMP. DISPENSING
- 4.1.2 - WATER ONLY
- 4.1.3 - POWDER ONLY
- 4.1.4 - NO ACCESSORIES
- 4.1.5 - ACCESSORIES ONLY

4.2 - SPEC. FUNCTIONS

- 4.2.1 - UNIT ROTATION
- 4.2.2 - RELEASE DOSE
- 4.2.3 - EMPTY BOILER
- 4.2.4 - MANUAL INSTALL.

4.3 - AUTOTEST

5 - MISCELLANEOUS

5.1 - MACHINE INFO

- 5.1.1 - INSTALL. DATE
- 5.1.2 - PROG. MACH. CODE
- 5.1.3 - PROG. OPER. CODE

5.2 - INITIALIZ. DB



NEXT FUNCTION/
INCREASE DATA UNIT (+1)



PREVIOUS FUNCTION /
DECREASE DATA UNIT (-1)



CONFIRM DATA /
CONFIRM FUNCTION



DELETE DATA /
EXIT FUNCTION

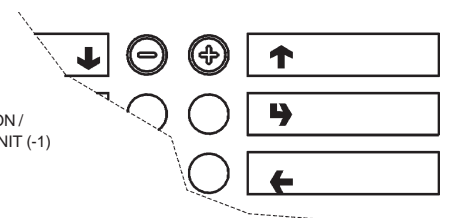

WIRING DIAGRAM LEGEND

INITIALS	DESCRIPTION	INITIALS	DESCRIPTION
BDV	BDV COIN MECH CONNECTORS	MF1-..	WHIPPER MOTORS
BFL	LIQUID WASTE TRAY SWITCH	MPU	SPOUT POSITIONING MICROSWITCH
CCG	GENERAL COUNTER	MSB	CUP RELEASE MOTOR
CM1	COFFEE UNIT MOTOR CAM	MSCB	CUP CONTAINER SHIFT MOTOR
CMSB	CUP RELEASE MOTOR CAM	MSP	STIRRER RELEASE MOTOR
CV	VOLUMETRIC COUNTER	MSV	TRAY MOVING MOTOR
E1-...	INSTANT SOLENOID VALVE	NTC	TEMPERATURE PROBE
EEA	WATER INLET SOLENOID VALVE	P1-...	SELECTION BUTTONS
ER	COFFEE DISPENSER SOLENOID VALV	PIP	PROGRAMMING BUTTON
ESC	COFFEE RELEASE MAGNET	PL	WASH CYCLE BUTTON
EX	EXECUTIVE COIN MECH CONNECTOR	PM	PUMP
FA	RADIO INTERFERENCE SUPPRESSOR	PPO	INGREDIENT PRIMING BUTTON
FREE	FREE VENDING SWITCH	PS1-..	SYRUP BUTTON
ID	COFFEE DOSE SWITCH	PSB	CUP RELEASE BUTTON
IMSP	STIRRER RELEASE MICRO-SWITCH	PST	STATISTICS BUTTON
IP	DOOR SWITCH	PSU	SPOUT SHIFT BUTTON
IPF	WASTE CONTAINER OVERFLOW SWITC	RCC	COFFEE BOILER HEATING ELEMENT
IVA	EMPTY BOILER MICRO-SWITCH	RIS	COFFEE UNIT HEATER
IVB	EMPTY CUP DISPENSER MICRO SWITC	RS232	SERIAL PORT
JUG	JUG FACILITIES SWITCH	SM1	CONTROL BOARD
KC1-..	COFFEE BOILER CUTOUT	SM2	EXPANSION BOARD
KS1-..	SAFETY CUTOUT	SP	PUSH-BUTTON BOARD
LCD	LIQUID CRYSTAL DISPLAY	STRC	BOILER HEATING TRIAC BOARD
LF	LAMP	SUC	C.P.U. BOARD
M	COFFEE UNIT MOTOR	TR	TRANSFORMER
MAC	GRINDER	TX....	DELAYED FUSE (X=COURRENT)
MD1-..	INGREDIENT MOTOR - INSTANT	TZ	CUP SENSOR
MDB	CONNECTOR FOR MDB COIN MECHANI	VAR	VARISTOR
MDTE	FRESH TEA INGREDIENT MOTOR	VENT	FAN
MDZ	INGREDIENT MOTOR - SUGAR		

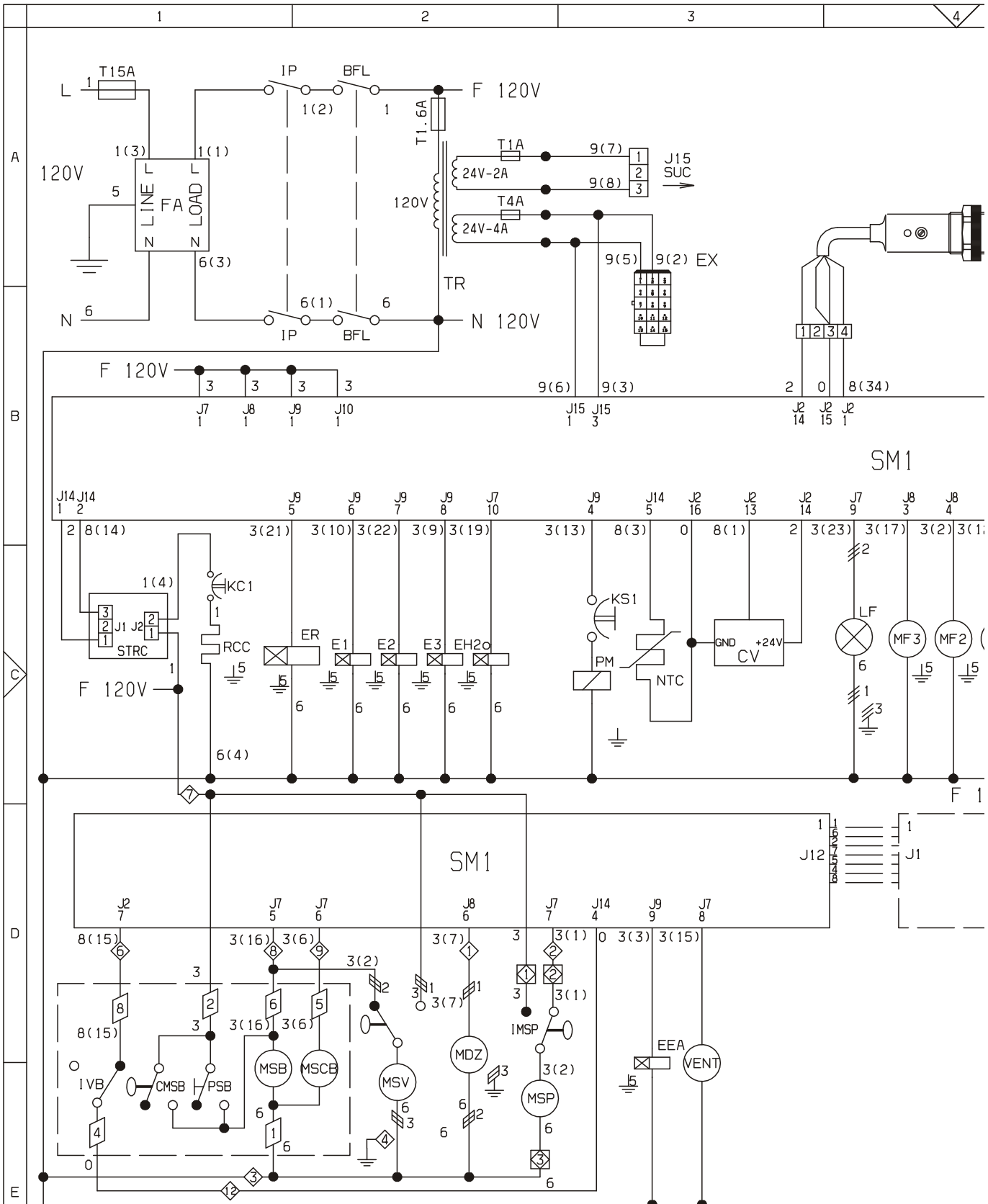

N&W GLOBAL VENDING S.P.A.
 SI RISERVA A TERMINI DI LEGGE
 LA PROPRIETA' DEL PRESENTE
 DISEGNO CON DIVIETO DI
 RIPRODURLO O DIVULGARLO SENZA
 SUA PREVIA AUTORIZZAZIONE

0	NERO
1	MARRONE
2	ROSSO
3	ARANCIO
4	GIALLO
5	VERDE
6	BLU
7	AZZURRO
8	ROSA
9	VIOLEA
0	GRIGIO
1	BIANCO
2	BLACK
3	BROWN
4	RED
5	ORANGE
6	YELLOW
7	GREEN
8	LIGHT BLUE
9	PINK
0	VIOLET
1	GREY
2	WHITE
3	MARRON
4	ROUGE
5	ORANGE
6	JAUNE
7	VERT
8	BLEU CIEL
9	ROSE
0	GRIS
1	BLANC
2	SCHWARZ
3	BRAUN
4	ROT
5	ORANGE
6	GELB
7	BLAU
8	HELLBLAU
9	ROSA
0	GRAU
1	WEISS
2	NEGRO
3	MARRON
4	POUR
5	MARANJA
6	AMARILLO
7	VERDE
8	OSCURO
9	AZUL CLARO
0	ROSA
1	ROSA
2	GRIS
3	BLANCO



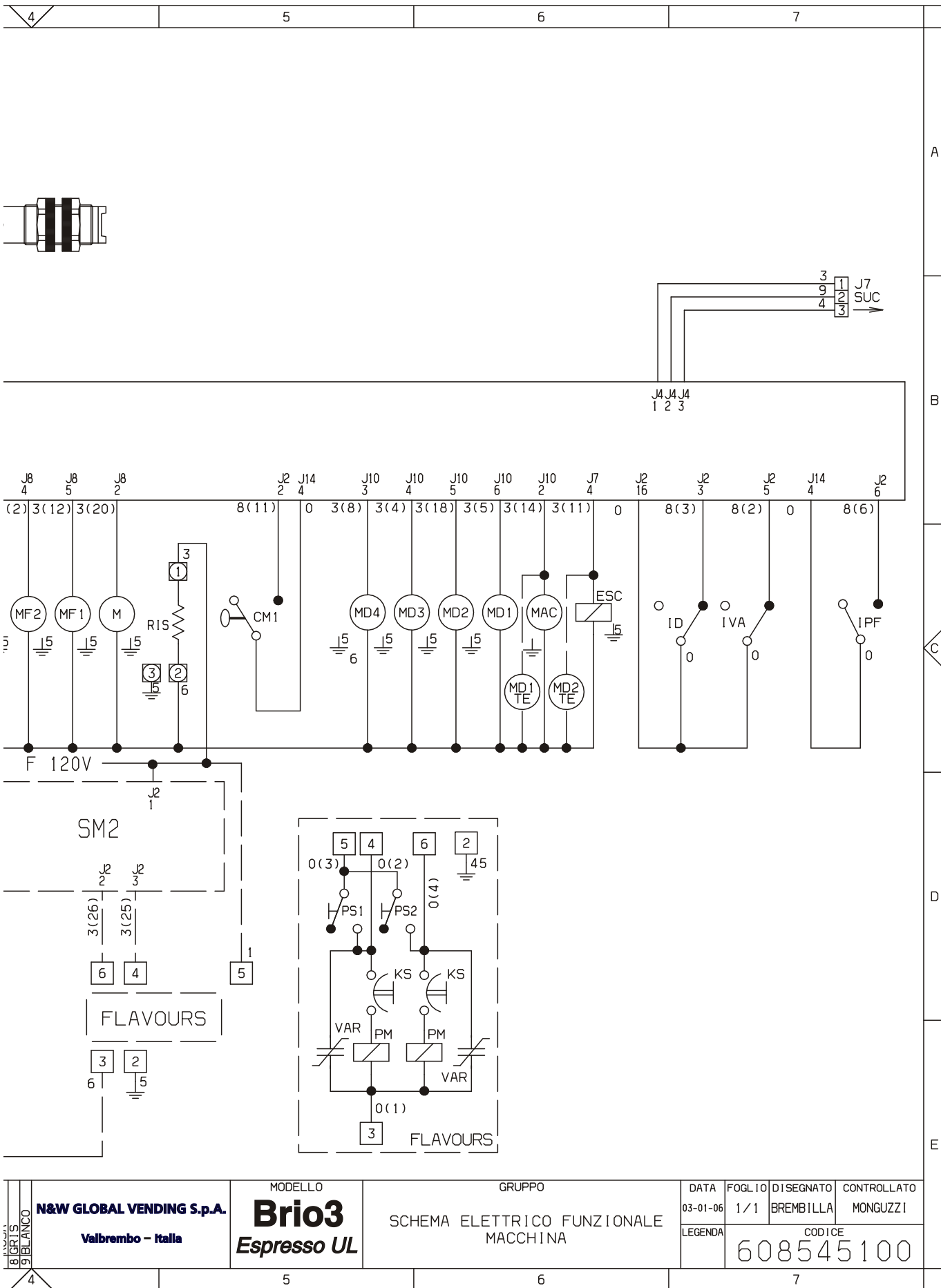

8 GRIS 9 BLANCO	N&W GLOBAL VENDING S.p.A. Valbrembo - Italia	MODELLO Brio3 Espresso UL	GRUPPO SCHEMA ELETTRICO FUNZIONALE MACCHINA	DATA 03-01-06	FOGLIO 1/1	DISEGNATO BREMBILLA	CONTROLLATO MONGUZZI
	LEGENDA						CODICE 608545100

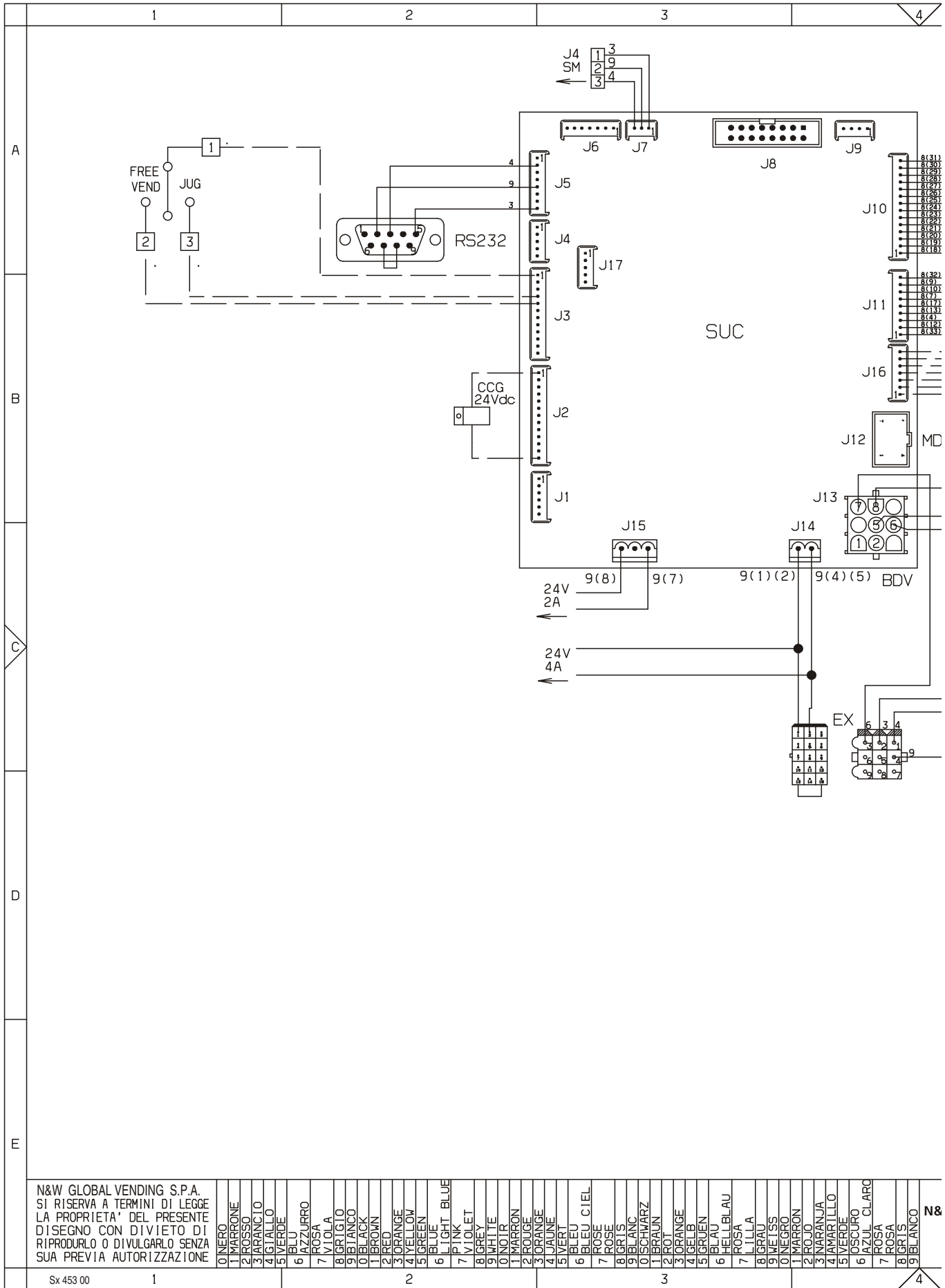

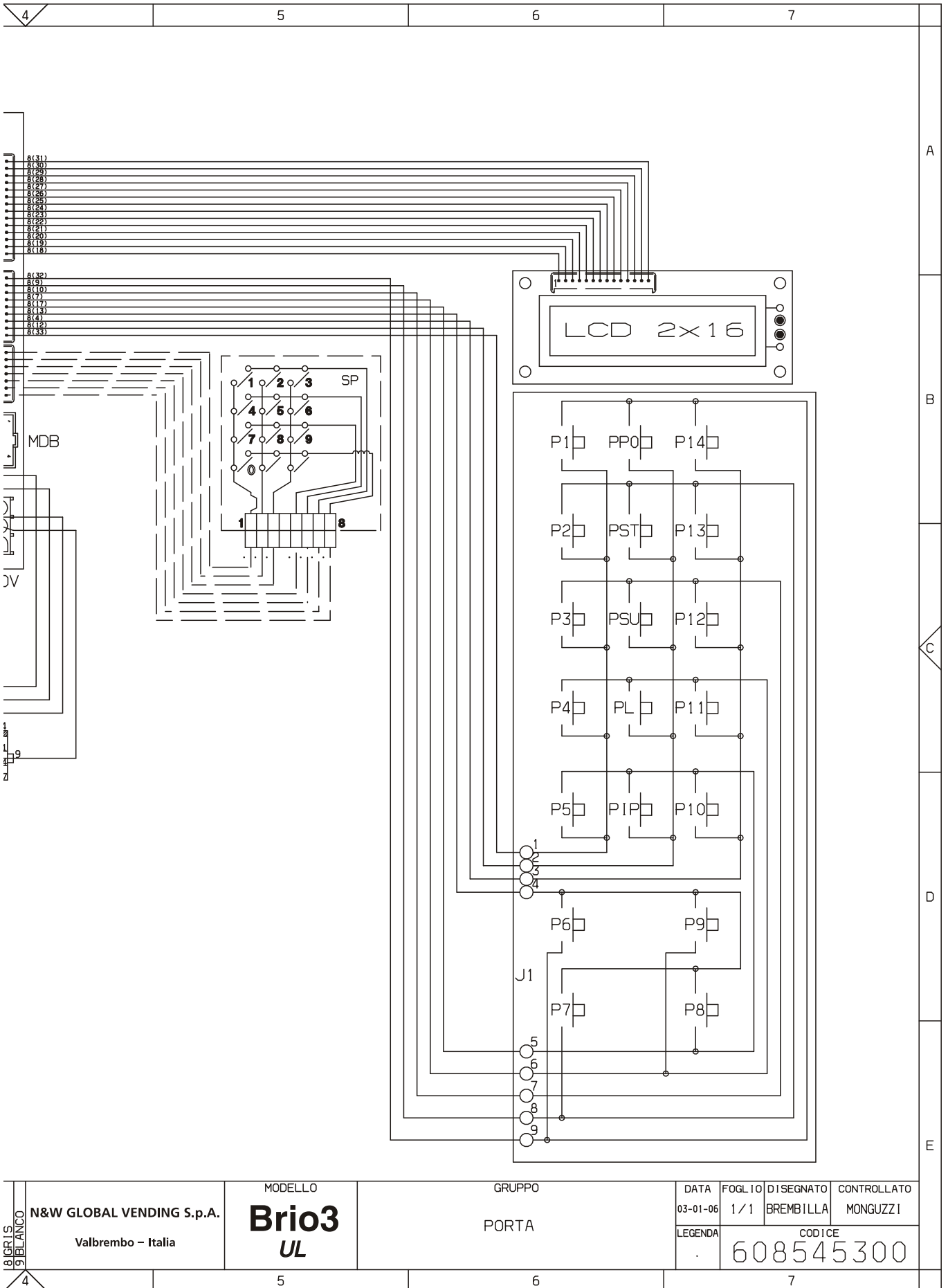

BGRIS BLANCO	N&W GLOBAL VENDING S.p.A. Valbrembo - Italia	MODELLO Brio3 UL	GRUPPO PORTA	DATA 03-01-06	FOGLIO 1/1	DISEGNATO BREMBILLA	CONTROLLATO MONGUZZI
					LEGENDA	CODICE	
					608545300		



The manufacturer reserves the right to modify, without prior notice, the characteristics of the equipment described in this publication; he declines all responsibility for any inaccuracies due to printing and/or typing errors herein contained. The instructions, drawings, tables and information in general contained in this booklet are of a confidential nature and may not be reproduced entirely or in part or be passed on to a third party without the prior written authorisation of the manufacturer who retains its exclusive ownership.

